

| CURRENT OWNER | | TOPO | UTILITIES | STRT / ROAD | LOCATION | CURRENT ASSESSMENT | | | | 801 FY2024 BARNSTABLE, MA VISION | |
|--|--|---------|----------------|---|----------|--------------------|------|----------|----------|--|---------|
| EHART, PATRICK J TR PATRICK J EHART 2016 TRUST 26 HINCKLEY CIRCLE OSTERVILLE MA 02655 | | 1 Level | 6 Septic | 1 Paved | | Description | Code | Assessed | Assessed | | |
| | | | 4 Gas | | | RESIDNTL | 1010 | 306,400 | 306,400 | | |
| | | | 2 Public Water | | | RES LAND | 1010 | 331,300 | 331,300 | | |
| SUPPLEMENTAL DATA | | | | | | Total | | | | 637,700 | 637,700 |
| Alt Prcl ID Split Zonin BID Parcel ResExpt Q YES: #DL 1 LOT 21 #DL 2 GIS ID F_962344_2692555 | | | | Plan Ref. 115/125 Land Ct# #SR Life Estate PP STATU Assoc Pid# | | | | | | | |

| RECORD OF OWNERSHIP | | BK-VOL/PAGE | SALE DATE | Q/U | V/I | SALE PRIC | VC | PREVIOUS ASSESSMENTS (HISTORY) | | | | | | | | |
|----------------------|--|-------------|-----------|------------|-----|-----------|---------|--------------------------------|---------|------|----------|------|---------|----------|-------|---------|
| EHART, PATRICK J TR | | 30156 | 0042 | 12-12-2016 | U | I | 1 | 1F | Year | Code | Assessed | Year | Code | Assessed | | |
| EHART, PATRICK J | | 27543 | 0127 | 07-15-2013 | U | I | 327,400 | | 2023 | 1010 | 267,100 | 2022 | 1010 | 233,900 | | |
| WEBER, ADELHEID L | | 24060 | 0199 | 09-28-2009 | U | I | 1 | 1F | | 1010 | 308,100 | | 1010 | 213,000 | | |
| WEBER, ADELHEID L TR | | 17615 | 0088 | 09-10-2003 | U | I | 0 | 1F | | | | | 1010 | 3,500 | | |
| WEBER, ADELHEID L | | 7880 | 0032 | 02-15-1992 | Q | I | 120,000 | U | Total | | | | | | | |
| | | | | | | | | | 575,200 | | Total | | 446,900 | | Total | 430,600 |

| EXEMPTIONS | | | | OTHER ASSESSMENTS | | | | This signature acknowledges a visit by a Data Collector or Assessor | | | | | | | | |
|------------|------|-----------------------|--------|-------------------|-------------|--------|--------|---|--|--|--|--|--|--|--|--|
| Year | Code | Description | Amount | Code | Description | Number | Amount | Comm Int | | | | | | | | |
| 2022 | 5C | RESIDENTIAL EXEMPTION | 0.00 | | | | | | | | | | | | | |
| Total | | | 0.00 | | | | | | | | | | | | | |

| ASSESSING NEIGHBORHOOD | | | | APPRAISED VALUE SUMMARY | | | |
|------------------------|-----------|---|---------|-------------------------|-------------------------------|---------|--|
| Nbhd | Nbhd Name | B | Tracing | Batch | | | |
| 0109 | | | | OSTVIL | Appraised Bldg. Value (Card) | 247,000 | |
| | | | | | Appraised Xf (B) Value (Bldg) | 55,900 | |
| | | | | | Appraised Ob (B) Value (Bldg) | 3,500 | |
| | | | | | Appraised Land Value (Bldg) | 331,300 | |
| | | | | | Special Land Value | 0 | |
| | | | | | Total Appraised Parcel Value | 637,700 | |
| | | | | | Valuation Method | C | |
| | | | | | Total Appraised Parcel Value | 637,700 | |

| NOTES | | | | | | | | VISIT / CHANGE HISTORY | | | | | | | |
|-------|--|--|--|--|--|--|--|------------------------|----|------|----|----|-----------------------|--|--|
| | | | | | | | | Date | Id | Type | Is | Cd | Purpost/Result | | |
| | | | | | | | | 12-22-2021 | AS | 03 | | 16 | In Office Review | | |
| | | | | | | | | 06-01-2020 | WD | | | FR | Field Review | | |
| | | | | | | | | 08-17-2017 | MS | 02 | | 03 | Cycl Insp Comp | | |
| | | | | | | | | 09-23-2015 | TP | 03 | | 16 | In Office Review | | |
| | | | | | | | | 01-14-2015 | AL | 22 | | 22 | Change of Address | | |
| | | | | | | | | 10-10-2014 | JR | 03 | | 20 | Sale Review | | |
| | | | | | | | | 12-11-2013 | MW | 05 | | 02 | Bldg Permit Completed | | |

| BUILDING PERMIT RECORD | | | | | | | | LAND LINE VALUATION SECTION | | | | | | | | |
|------------------------|------------|------|-------------|--------|------------|--------|------------|-----------------------------|--|--|--|--|--|--|--|--|
| Permit Id | Issue Date | Type | Description | Amount | Insp Date | % Comp | Date Comp | Comments | | | | | | | | |
| 201205641 | 10-05-2012 | RW | Repair Work | 20,000 | 11-20-2013 | 100 | 06-30-2014 | REPAIR WTR DAM IN BMT-S | | | | | | | | |
| 200707933 | 12-11-2007 | NW | New Windows | 5,000 | | 0 | | EXPIRED-EGRESS WINDS-N | | | | | | | | |

| B | Use Code | Description | Zone | LA | Land Units | Unit Price | Size Adj | AC Disc | Site Index | Cond. | Nbhd. | Nbhd. Adj | Notes | Location Adjustmen | Adj Unit P | Land Value | |
|-----------------------|----------|----------------|------|----|------------|------------|------------------------|---------|------------|-------|-------|-----------|------------------|--------------------|------------|------------|---------|
| 1 | 1010 | Single Fam M-0 | RC | 3 | 0.300 | AC | 176,344.00 | 2.84692 | 1.0000 | 5 | 1.00 | 0109 | 2.200 | | 1.0000 | 1,104,477 | 331,300 |
| Total Card Land Units | | | | | 0.30 | AC | Parcel Total Land Area | | | | | 0.30 | Total Land Value | | | 331,300 | |

| CONSTRUCTION DETAIL | | | CONSTRUCTION DETAIL (CONTINUED) | | |
|---------------------|----|----------------|---------------------------------|----|-------------|
| Element | Cd | Description | Element | Cd | Description |
| Style | 01 | Ranch | | | |
| Model | 01 | Residential | | | |
| Grade: | C | Average | | | |
| Stories | 1 | 1 Story | | | |
| Exterior Wall 1 | 14 | Wood Shingle | | | |
| Exterior Wall 2 | | | | | |
| RooF Structure | 03 | Gable/Hip | | | |
| RooF Cover | 03 | Asph/F Gls/Cmp | | | |
| Interior Wall 1 | 05 | Drywall | | | |
| Interior Wall 2 | | | | | |
| Interior Floor 1 | 09 | Pine/Soft Wood | | | |
| Interior Floor 2 | 11 | Ceram Clay Til | | | |
| Heat Fuel | 03 | Gas | | | |
| Heat Type | 05 | Hot Water | | | |
| AC Type | 01 | None | | | |
| Bedrooms | 02 | 2 Bedrooms | | | |
| Full Baths | 2 | | | | |
| Half Baths | 0 | | | | |
| Extra Fixtures | | | | | |
| Total Rooms | 5 | 5 Rooms | | | |
| Bath Style | | | | | |
| Kitchen Style | | | | | |
| Occupancy | | | | | |
| Usrflid 105 | | | | | |
| Accessory Apt | Y | Apt here | | | |
| Foundation Alt | 02 | Conc. Block | | | |
| Rms Prts | | | | | |
| Bath Split | 20 | 2 Full-0 Half | | | |

| CONDO DATA | | | | |
|-------------|------|-------------|---------|-----|
| Parcel Id | | C | Owne | 0.0 |
| | | | | |
| Adjust Type | Code | Description | Factor% | |
| Condo Flr | | | | |
| Condo Unit | | | | |

| COST / MARKET VALUATION | | |
|--------------------------|--|---------|
| Building Value New | | 333,756 |
| Year Built | | 1958 |
| Effective Year Built | | 1985 |
| Depreciation Code | | A |
| Remodel Rating | | |
| Year Remodeled | | |
| Depreciation % | | 26 |
| Functional Obsol | | 0 |
| External Obsol | | 0 |
| Trend Factor | | 1 |
| Condition | | |
| Condition % | | |
| Percent Good | | 74 |
| RCNLD | | 247,000 |
| Dep % Ovr | | |
| Dep Ovr Comment | | |
| Misc Imp Ovr | | |
| Misc Imp Ovr Comment | | |
| Cost to Cure Ovr | | |
| Cost to Cure Ovr Comment | | |

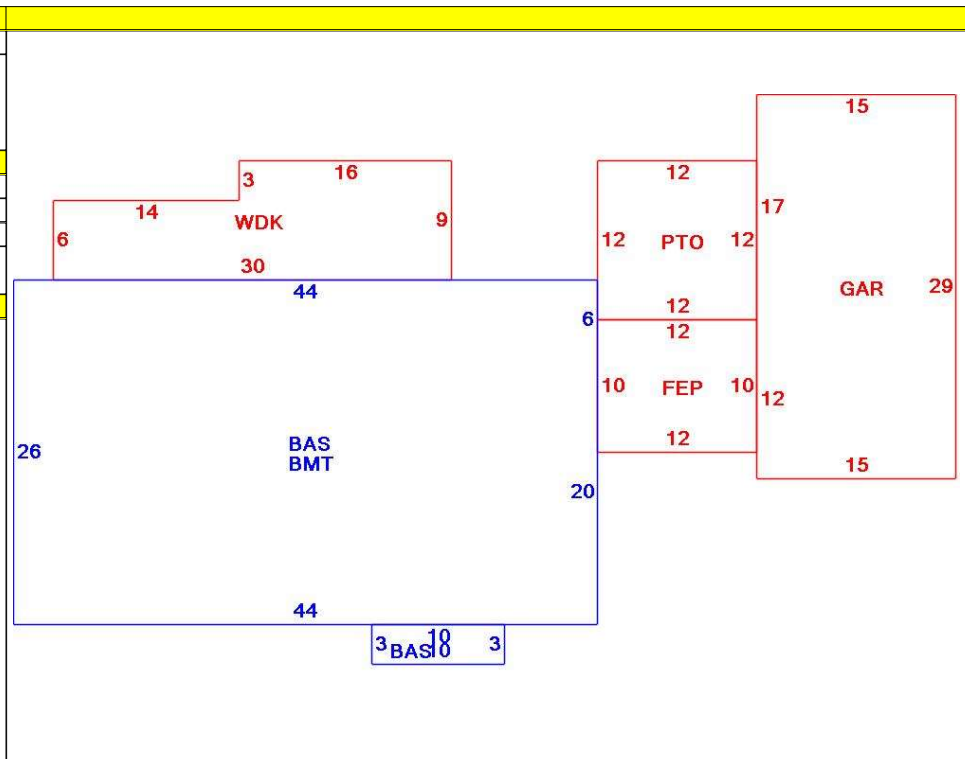

| OB - OUTBUILDING & YARD ITEMS(L) / XF - BUILDING EXTRA FEATURES(B) | | | | | | | | | | |
|--|-----------------|-----|-------|------------|--------|----------|------|-------|------------|-------------|
| Code | Description | L/B | Units | Unit Price | Yr Blt | Cond. Cd | % Gd | Grade | Grade Adj. | Appr. Value |
| FPL1 | Fireplace 1 sto | B | 1 | 5000.00 | 1987 | | 74 | | 0.00 | 3,700 |
| FPO | Ext FP Openin | B | 1 | 2000.00 | 1987 | | 74 | | 0.00 | 1,500 |
| BFA | Bsmt Fin-Avg | B | 760 | 17.36 | 1987 | | 74 | | 0.00 | 9,800 |
| WDC | Wood Decking | L | 228 | 20.00 | 1992 | | 46 | | 0.00 | 2,300 |
| FEP | Enclosed porc | B | 120 | 70.00 | 1987 | | 74 | | 0.00 | 6,900 |
| GAR | Attached Gara | B | 435 | 40.00 | 1987 | | 74 | | 0.00 | 12,500 |
| BMT | Basement-Unfi | B | 1,144 | 26.01 | 1987 | | 74 | | 0.00 | 21,500 |
| PAT2 | Patio-Good | L | 144 | 9.94 | 1993 | | 74 | | 0.00 | 1,200 |

| BUILDING SUB-AREA SUMMARY SECTION | | | | | | |
|-----------------------------------|-----------------|-------------|------------|----------|-----------|----------------|
| Code | Description | Living Area | Floor Area | Eff Area | Unit Cost | Undeprec Value |
| BAS | First Floor | 1,174 | 1,174 | 1,174 | 284.29 | 333,756 |
| BMT | Basement Area | 0 | 1,144 | 0 | 0.00 | 0 |
| FEP | Enclosed Porch | 0 | 120 | 0 | 0.00 | 0 |
| GAR | Attached Garage | 0 | 435 | 0 | 0.00 | 0 |
| PTO | Patio | 0 | 144 | 0 | 0.00 | 0 |
| WDK | Wood Deck | 0 | 228 | 0 | 0.00 | 0 |
| Ttl Gross Liv / Lease Area | | 1,174 | 3,245 | 1,174 | | 333,756 |

