

CURRENT OWNER		TOPO	UTILITIES	STRT / ROAD	LOCATION	CURRENT ASSESSMENT												
MCGONIGLE, MICHAEL P						Description	Code	Assessed	Assessed	801 FY2024 BARNSTABLE, MA  <b>VISION</b>								
3 TAFT CIRCLE		<b>SUPPLEMENTAL DATA</b>				RESIDNTL	1020	917,700	917,700									
WINCHESTER MA 01890		Alt Prcl ID Split Zonin BID Parcel ResExpt Q #DL 1 UNIT B7 #DL 2 BLDG B GIS ID F_961968_2691576				Plan Ref. 431/76-82, 449/74 Land Ct# #SR Life Estate PP STATU Assoc Pid#		Total 917,700 917,700										
						Total		917,700	917,700									
RECORD OF OWNERSHIP		BK-VOL/PAGE	SALE DATE	Q/U	V/I	SALE PRICE	VC	PREVIOUS ASSESSMENTS (HISTORY)										
MCGONIGLE, MICHAEL P		12776 0188	01-12-2000	U	I	100	1A	Year	Code	Assessed	Year	Code	Assessed					
MCGONIGLE, MARY LOU		9238 0092	06-15-1994			0		2023	1020	639,300	2022	1020	595,300					
MURPHY, ROSE TR		7650 0250	08-15-1991	Q	I	177,500	U				2021	1020	598,700					
												1020	3,400					
								Total		639,300	Total		595,300					
								Total			Total		602,100					
EXEMPTIONS			OTHER ASSESSMENTS				This signature acknowledges a visit by a Data Collector or Assessor											
Year	Code	Description	Amount	Code	Description	Number	Amount	Comm Int										
Total			0.00															
ASSESSING NEIGHBORHOOD								<b>APPRAISED VALUE SUMMARY</b>										
Nbhd	Nbhd Name		B	Tracing		Batch		Appraised Bldg. Value (Card)				882,700						
0001						OSTVIL		Appraised Xf (B) Value (Bldg)				31,600						
								Appraised Ob (B) Value (Bldg)				3,400						
								Appraised Land Value (Bldg)				0						
								Special Land Value				0						
								Total Appraised Parcel Value				917,700						
								Valuation Method				C						
								Total Appraised Parcel Value				917,700						
BUILDING PERMIT RECORD								VISIT / CHANGE HISTORY										
Permit Id	Issue Date	Type	Description	Amount	Insp Date	% Comp	Date Comp	Comments	Date	Id	Type	Is	Cd	Purpost/Result				
									06-03-2020	WD			FR	Field Review				
									05-21-2019	SR	02		03	Cycl Insp Comp				
									07-30-2015	TP	03		16	In Office Review				
LAND LINE VALUATION SECTION																		
B	Use Code	Description	Zone	Dist	Land Type	Land Units	Unit Price	Size Adj	Site Index	Cond.	Nbhd.	Nbhd. Adj	Notes	Location Adjustmen	Adj Unit P	Land Value		
1	102U	Condominium M	BA	3		0 SF	0.00	1.00000	5	1.00	0001	1.000			0.0000	0		
Total Card Land Units						0 SF	Parcel Total Land Area						0.00	Total Land Value				0

CONSTRUCTION DETAIL			CONSTRUCTION DETAIL (CONTINUED)		
Element	Cd	Description	Element	Cd	Description
Style	55	Condominium			
Model	05	Res Condo			
Bedrm Func	B	Custom			
Stories	2	2 Stories			
Occupancy	0				
Interior Wall 1	03	Plastered			
Interior Wall 2					
Interior Floor 1	12	Hardwood			
Interior Floor 2					
Heat Fuel	04	Electric			
Heat Type	07	Elec Baseboard			
AC Type	02	Heat Pump			
Bedrooms	03	3 Bedrooms			
Full Baths	2	2 Full			
Half Baths	1				
Extra Fixtures					
Total Rooms	6	6 Rooms			
Bath Style					
Kitchen Style					
Master Deed L	1634				
Bath Split	21	2 Full-1 Half			
Foundation	01	Poured Conc.			
AC Type Alt					
Sewer Occupan					
<b>CONDO DATA</b>					
Parcel Id	104203	C 0039	Owne	8.1	
	VILLAGE AT COT	B 1	S 1		
Adjust Type	Code	Description	Factor%		
Condo Flr	END	END UNIT	100		
Condo Unit	MKT0	MKT0	100		
<b>COST / MARKET VALUATION</b>					
Building Value New		1,003,112			
Year Built		1987			
Effective Year Built		2003			
Depreciation Code		A			
Remodel Rating					
Year Remodeled		12			
Depreciation %		0			
Functional Obsol		0			
External Obsol		0			
Trend Factor		1			
Condition					
Condition %		88			
Cns Sect Rcnld		882,700			
Dep % Ovr					
Dep Ovr Comment					
Misc Imp Ovr					
Misc Imp Ovr Comment					
Cost to Cure Ovr					
Cost to Cure Ovr Comment					

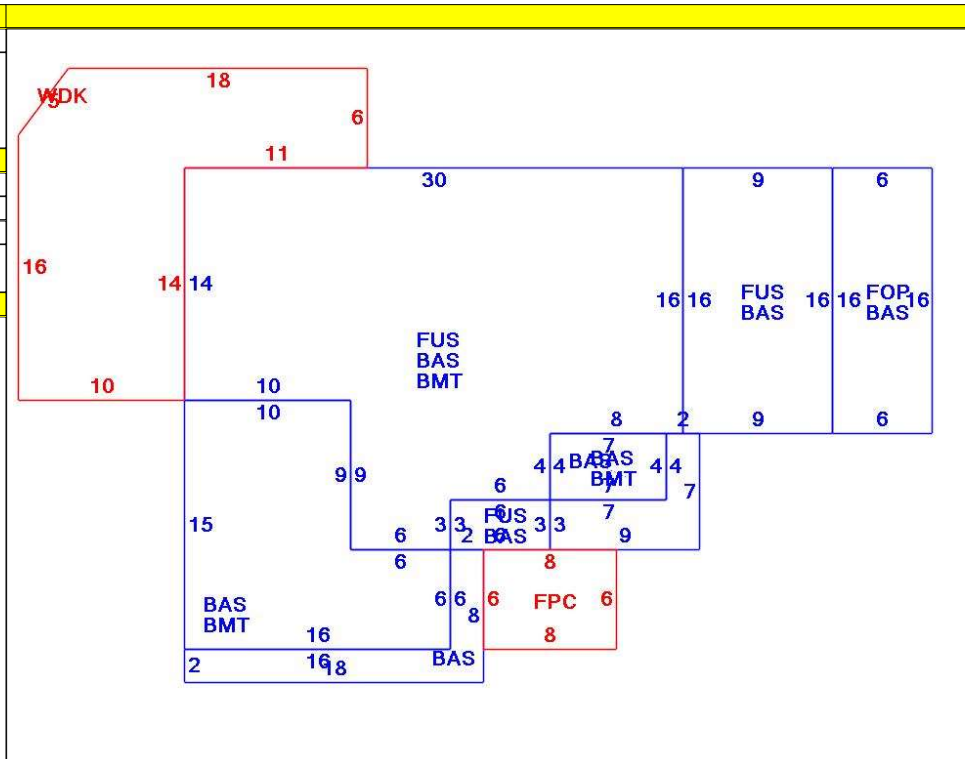

OB - OUTBUILDING & YARD ITEMS(L) / XF - BUILDING EXTRA FEATURES(B)										
Code	Description	L/B	Units	Unit Price	Yr Blt	Cond. Cd	% Gd	Grade	Grade Adj.	Appr. Value
FPL2	Fireplace 1.5 s	B	1	6000.00	2005		88		0.00	5,300
BMT	Basement-Unfi	B	740	26.01	2005		88		0.00	19,100
FOPC	Open Prch-roo	B	48	55.00	2005		88		0.00	2,500
FOP	Open Porch-ro	B	96	55.00	2005		88		0.00	4,700
WDC	Wood Deck w/	L	260	18.00	2003		68		0.00	3,400

BUILDING SUB-AREA SUMMARY SECTION						
Code	Description	Living Area	Floor Area	Eff Area	Unit Cost	Undeprec Value
BAS	First Floor	1,081	1,081	1,081	567.05	612,982
BMT	Basement Area	0	740	0	0.00	0
FOP	Open Porch	0	96	0	0.00	0
FPC	Open Porch Conc. Floor	0	48	0	0.00	0
FUS	Upper Story	688	688	688	567.05	390,131
WDK	Wood Deck	0	260	0	0.00	0
Ttl Gross Liv / Lease Area		1,769	2,913	1,769		1,003,113

