

| CURRENT OWNER | | TOPO | UTILITIES | STRT / ROAD | LOCATION | CURRENT ASSESSMENT | | | |
|--|--|----------|----------------|-------------|---|--------------------------------------|----------------------|------------------------------------|------------------------------------|
| ELLIS, STEVEN M & ROBIN L 41 MOUNT VERNON STREET NO. 5 BOSTON MA 02108 | | 1 Level | 2 Public Water | 1 Paved | 7 Waterfront | Description RESIDENTL RES LAND | Code 1010 1010 | Assessed 1,022,000 2,203,700 | Assessed 1,022,000 2,203,700 |
| | | 5 Well | | | 1 Excel View | | | | |
| | | 6 Septic | | | | | | | |
| SUPPLEMENTAL DATA | | | | | | | | | |
| Alt Prcl ID Split Zonin BID Parcel ResExpt Q #DL 1 LOT 4 #DL 2 GIS ID F_942866_2680784 | | | | | Plan Ref. Land Ct# 34636-B (1) #SR Life Estate PP STATU Assoc Pid# | | | | |
| | | | | | | Total | | 3,225,700 | 3,225,700 |

801
 FY2024
 BARNSTABLE, MA

VISION

| RECORD OF OWNERSHIP | | BK-VOL/PAGE | SALE DATE | Q/U | V/I | SALE PRIC | VC | PREVIOUS ASSESSMENTS (HISTORY) | | | | | | | | |
|------------------------------|--|-------------|------------|-----|-----|-----------|----|--------------------------------|------|-----------|-------|------|-----------|-------|--|-----------|
| ELLIS, STEVEN M & ROBIN L | | C186637 0 | 08-07-2008 | Q | I | 2,300,000 | 00 | Year | Code | Assessed | Year | Code | Assessed | | | |
| MCPARLAND, BETH F | | C126599 0 | 05-15-1992 | Q | I | 475,000 | 00 | 2023 | 1010 | 811,900 | 2022 | 1010 | 754,600 | | | |
| BRESK, RAYMOND H & ANNETTE A | | C84271 0 | 01-15-1981 | Q | | 70,500 | U | | 1010 | 2,848,500 | | 1010 | 1,481,100 | | | |
| | | | | | | | | Total | | 3,660,400 | Total | | 2,235,700 | Total | | 2,147,000 |

| EXEMPTIONS | | | | OTHER ASSESSMENTS | | | |
|------------|------|-------------|--------|-------------------|-------------|--------|--------|
| Year | Code | Description | Amount | Code | Description | Number | Amount |
| | | | | | | | |
| | | | Total | | | | |
| | | | 0.00 | | | | |

This signature acknowledges a visit by a Data Collector or Assessor

| ASSESSING NEIGHBORHOOD | | | |
|------------------------|-----------|---|---------|
| Nbhd | Nbhd Name | B | Tracing |
| 0119 | | | COTUIT |

| NOTES | | | |
|-------|--|--|--|
| | | | |

| APPRAISED VALUE SUMMARY | |
|-------------------------------|-----------|
| Appraised Bldg. Value (Card) | 860,500 |
| Appraised Xf (B) Value (Bldg) | 77,300 |
| Appraised Ob (B) Value (Bldg) | 84,200 |
| Appraised Land Value (Bldg) | 2,203,700 |
| Special Land Value | 0 |
| Total Appraised Parcel Value | 3,225,700 |
| Valuation Method | C |
| Total Appraised Parcel Value | 3,225,700 |

| BUILDING PERMIT RECORD | | | | | | | | | VISIT / CHANGE HISTORY | | | | | |
|------------------------|------------|------|----------------|---------|------------|--------|------------|---------------------------|------------------------|----|------|----|----|-----------------------|
| Permit Id | Issue Date | Type | Description | Amount | Insp Date | % Comp | Date Comp | Comments | Date | Id | Type | Is | Cd | Purpost/Result |
| 201306247 | 10-09-2013 | RA | Remodel-Additi | 250,000 | 06-27-2014 | 100 | 06-30-2014 | MODIFY ROOFLINE-ADD DO | 06-04-2020 | DM | | | FR | Field Review |
| 201208081 | 12-31-2012 | PH | Pool Heater | 0 | 06-27-2012 | 100 | 06-30-2012 | POOL HTR | 10-26-2018 | KM | 22 | | 22 | Change of Address |
| 201206714 | 11-08-2012 | AD | Addition | 55,000 | 07-10-2013 | 100 | 06-30-2013 | SCREEN PORCH 16X16 | 04-02-2015 | JR | 03 | | 03 | Cycl Insp Comp |
| 201104585 | 08-31-2011 | FB | Finish Basemen | 10,000 | 07-10-2013 | 100 | 06-30-2013 | FIN WALLS & CEIL IN BMT L | 07-23-2014 | MW | 02 | | 02 | Bldg Permit Completed |
| 201104583 | 08-25-2011 | NW | New Windows | 5,900 | 06-30-2012 | 100 | 06-30-2012 | 2 NW WINDS | 05-02-2014 | MW | 01 | | 13 | CALL BACK |
| 200905922 | 12-04-2009 | FP | Fireplace | 0 | 04-22-2013 | 0 | | EXPIRED FOR FPL & COOKT | 07-23-2013 | RB | 03 | | 02 | Bldg Permit Completed |
| B36634 | 04-01-1994 | RE | Remodel | 4,000 | 01-15-1995 | 100 | 06-30-1985 | CO REMODE | 05-01-2013 | RB | 03 | | 13 | CALL BACK |

| LAND LINE VALUATION SECTION | | | | | | | | | | | | | | | | | |
|-----------------------------|----------|----------------|------|----|------------|---------------|------------------------|---------|------------|-------|-------|-----------|------------------|--------------------|------------|------------|-----------|
| B | Use Code | Description | Zone | LA | Land Units | Unit Price | Size Adj | AC Disc | Site Index | Cond. | Nbhd. | Nbhd. Adj | Notes | Location Adjustmen | Adj Unit P | Land Value | |
| 1 | 1010 | Single Fam M-0 | RF | 2 | 1.000 | AC 176,344.00 | 1.00000 | 1.0000 | 5 | 1.00 | 0119 | 12.000 | | 1.0000 | 2,116,128 | 2,116,100 | |
| 1 | 1010 | Single Fam M-0 | RF | 2 | 0.500 | AC 14,250.00 | 1.00000 | 1.0000 | 0 | 1.00 | 0119 | 12.000 | | 1.0000 | 171,000 | 85,500 | |
| 1 | 1010 | Single Fam M-0 | RF | 2 | 0.900 | AC 2,375.00 | 1.00000 | 1.0000 | 0 | 1.00 | WTLD | 1.000 | WETLAND | 1.0000 | 2,375 | 2,100 | |
| Total Card Land Units | | | | | 2.40 | AC | Parcel Total Land Area | | | | | 2.40 | Total Land Value | | | | 2,203,700 |

| CONSTRUCTION DETAIL | | | CONSTRUCTION DETAIL (CONTINUED) | | |
|---------------------|----|----------------|--------------------------------------|----|-------------|
| Element | Cd | Description | Element | Cd | Description |
| Style | 07 | Modern/Contemp | | | |
| Model | 01 | Residential | | | |
| Grade: | B+ | Custom Plus | | | |
| Stories | 2 | 2 Stories | | | |
| Exterior Wall 1 | 14 | Wood Shingle | | | |
| Exterior Wall 2 | | | | | |
| RooF Structure | 03 | Gable/Hip | | | |
| RooF Cover | 10 | Wood Shingle | | | |
| Interior Wall 1 | 05 | Drywall | | | |
| Interior Wall 2 | 02 | Wall Brd/Wood | | | |
| Interior Floor 1 | 14 | Carpet | | | |
| Interior Floor 2 | 12 | Hardwood | | | |
| Heat Fuel | 03 | Gas | | | |
| Heat Type | 04 | Hot Air | | | |
| AC Type | 03 | Central | | | |
| Bedrooms | 04 | 4 Bedrooms | | | |
| Full Baths | 3 | | | | |
| Half Baths | 2 | | | | |
| Extra Fixtures | | | | | |
| Total Rooms | 7 | | | | |
| Bath Style | | | | | |
| Kitchen Style | | | | | |
| Occupancy | | | | | |
| Usrflid 105 | | | | | |
| Accessory Apt | | | | | |
| Foundation Alt | 01 | Poured Conc. | | | |
| Rms Prts | | | | | |
| Bath Split | 32 | 3 Full-2 Half | | | |
| | | | CONDO DATA | | |
| | | | Parcel Id | C | Owne 0.0 |
| | | | Adjust Type Code Description Factor% | | |
| | | | Condo Flr | | |
| | | | Condo Unit | | |
| | | | COST / MARKET VALUATION | | |
| | | | Building Value New | | 1,024,417 |
| | | | Year Built | | 1985 |
| | | | Effective Year Built | | 1998 |
| | | | Depreciation Code | | A |
| | | | Remodel Rating | | |
| | | | Year Remodeled | | |
| | | | Depreciation % | | 16 |
| | | | Functional Obsol | | 0 |
| | | | External Obsol | | 0 |
| | | | Trend Factor | | 1 |
| | | | Condition | | |
| | | | Condition % | | |
| | | | Percent Good | | 84 |
| | | | RCNLD | | 860,500 |
| | | | Dep % Ovr | | |
| | | | Dep Ovr Comment | | |
| | | | Misc Imp Ovr | | |
| | | | Misc Imp Ovr Comment | | |
| | | | Cost to Cure Ovr | | |
| | | | Cost to Cure Ovr Comment | | |

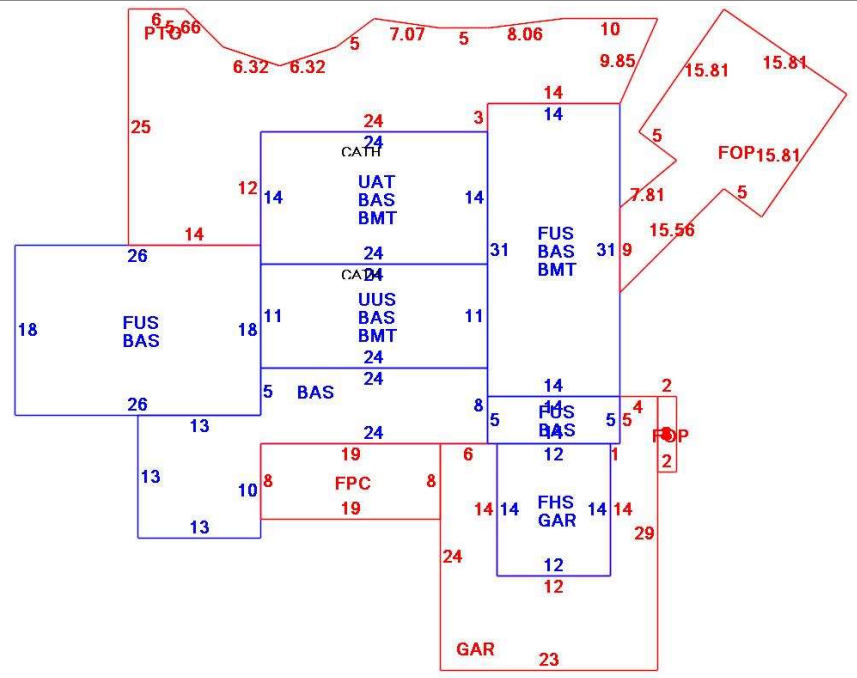

| OB - OUTBUILDING & YARD ITEMS(L) / XF - BUILDING EXTRA FEATURES(B) | | | | | | | | | | |
|--|-----------------|-----|-------|------------|--------|----------|------|-------|------------|-------------|
| Code | Description | L/B | Units | Unit Price | Yr Blt | Cond. Cd | % Gd | Grade | Grade Adj. | Appr. Value |
| SPL3 | Pool Gunite | L | 450 | 75.00 | 1985 | | 32 | 00 | 1.00 | 12,500 |
| DKAV | Dock-Ave | L | 1 | 100000.0 | 1995 | | 52 | | 0.00 | 52,000 |
| PATF | Flagstone Pav | L | 704 | 30.00 | 1999 | | 80 | | 0.00 | 15,900 |
| FOPC | Open Prch-roo | B | 152 | 55.00 | 2000 | | 84 | | 0.00 | 5,200 |
| GAR | Attached Gara | B | 572 | 40.00 | 2000 | | 84 | | 0.00 | 17,100 |
| BMT | Basement-Unfi | B | 1,034 | 26.01 | 2000 | | 84 | | 0.00 | 22,800 |
| SPH1 | Pool Heater < | L | 1 | 2434.00 | 2013 | | 88 | | 0.00 | 2,100 |
| STRS | Stairs to Water | L | 16 | 122.52 | 2013 | | 88 | C | 1.00 | 1,700 |
| BFA1 | Bsmt Fin-Goo | B | 696 | 32.56 | 2000 | | 84 | | 0.00 | 19,000 |
| FOP | Open Porch-ro | B | 337 | 55.00 | 2000 | | 84 | | 0.00 | 11,100 |

| BUILDING SUB-AREA SUMMARY SECTION | | | | | | |
|-----------------------------------|-------------------------|-------------|------------|----------|-----------|----------------|
| Code | Description | Living Area | Floor Area | Eff Area | Unit Cost | Undeprec Value |
| BAS | First Floor | 1,933 | 1,933 | 1,933 | 315.15 | 609,183 |
| BMT | Basement Area | 0 | 1,034 | 0 | 0.00 | 0 |
| FHS | Half Story | 84 | 168 | 84 | 157.57 | 26,473 |
| FOP | Open Porch | 0 | 337 | 0 | 0.00 | 0 |
| FPC | Open Porch Conc. Floor | 0 | 152 | 0 | 0.00 | 0 |
| FUS | Upper Story | 972 | 972 | 972 | 315.15 | 306,325 |
| GAR | Attached Garage | 0 | 572 | 0 | 0.00 | 0 |
| PTO | Patio | 0 | 704 | 0 | 0.00 | 0 |
| UAT | Attic, Unfinished | 0 | 336 | 34 | 31.89 | 10,715 |
| UUS | Upper Story, Unfinished | 0 | 264 | 224 | 267.40 | 70,593 |
| Ttl Gross Liv / Lease Area | | 2,989 | 6,472 | 3,247 | | 1,023,289 |



| CURRENT OWNER | | TOPO | | UTILITIES | | STRT / ROAD | | LOCATION | | CURRENT ASSESSMENT | | | | 801 FY2024 BARNSTABLE, MA VISION | | | | | | |
|--|------------|-------------|-------------|---|------------------------|-------------|-------------|---|------------|--------------------|----------|--------------------------------|--------------------------------|--|--------------------|------------|----------------|-------|------|-----------|
| ELLIS, STEVEN M & ROBIN L 41 MOUNT VERNON STREET NO. 5 BOSTON MA 02108 | | 1 | Level | 2 | Public Water | 1 | Paved | 7 | Waterfront | Description | Code | Assessed | Assessed | | | | | | | |
| | | 5 | Well | | | | | 1 | Excel View | RESIDNTL | 1010 | 1,022,000 | 1,022,000 | | | | | | | |
| | | 6 | Septic | | | | | | | RES LAND | 1010 | 2,203,700 | 2,203,700 | | | | | | | |
| SUPPLEMENTAL DATA | | | | | | | | | | Total | | 3,225,700 | 3,225,700 | | | | | | | |
| Alt Prcl ID Split Zonin BID Parcel ResExpt Q #DL 1 LOT 4 #DL 2 GIS ID F_942866_2680784 | | | | Plan Ref. Land Ct# 34636-B (1) #SR Life Estate PP STATU Assoc Pid# | | | | | | | | | | | | | | | | |
| RECORD OF OWNERSHIP | | | BK-VOL/PAGE | | SALE DATE | | Q/U | V/I | SALE PRIC | | VC | PREVIOUS ASSESSMENTS (HISTORY) | | | | | | | | |
| | | | | | | | | | | | | Year | Code | Assessed | Year | Code | Assessed | Year | Code | Assessed |
| | | | | | | | | | | | | 2023 | 1010 | 811,900 | 2022 | 1010 | 754,600 | 2021 | 1010 | 581,700 |
| | | | | | | | | | | | | | 1010 | 2,848,500 | | 1010 | 1,481,100 | | 1010 | 1,481,100 |
| | | | | | | | | | | | | Total | | 3,660,400 | Total | | 2,235,700 | Total | | 2,147,000 |
| EXEMPTIONS | | | | OTHER ASSESSMENTS | | | | This signature acknowledges a visit by a Data Collector or Assessor | | | | | | | | | | | | |
| Year | Code | Description | | Amount | | Code | Description | Number | Amount | | Comm Int | | APPRAISED VALUE SUMMARY | | | | | | | |
| | | | | | | | | | | | | Appraised Bldg. Value (Card) | | | | 860,500 | | | | |
| | | | | | | | | | | | | Appraised Xf (B) Value (Bldg) | | | | 77,300 | | | | |
| | | | | | | | | | | | | Appraised Ob (B) Value (Bldg) | | | | 84,200 | | | | |
| | | | | | | | | | | | | Appraised Land Value (Bldg) | | | | 2,203,700 | | | | |
| | | | | | | | | | | | | Special Land Value | | | | 0 | | | | |
| | | | | | | | | | | | | Total Appraised Parcel Value | | | | 3,225,700 | | | | |
| | | | | | | | | | | | | Valuation Method | | | | C | | | | |
| | | | | | | | | | | | | Total Appraised Parcel Value | | | | 3,225,700 | | | | |
| BUILDING PERMIT RECORD | | | | | | | | | | | | VISIT / CHANGE HISTORY | | | | | | | | |
| Permit Id | Issue Date | Type | Description | Amount | Insp Date | % Comp | Date Comp | Comments | | | | Date | Id | Type | Is | Cd | Purpost/Result | | | |
| | | | | | | | | | | | | | | | | | | | | |
| LAND LINE VALUATION SECTION | | | | | | | | | | | | | | | | | | | | |
| B | Use Code | Description | Zone | LA | Land Units | Unit Price | Size Adj | AC Disc | Site Index | Cond. | Nbhd. | Nbhd. Adj | Notes | | Location Adjustmen | Adj Unit P | Land Value | | | |
| | | | | | | | | | | | | | | | | | | | | |
| Total Card Land Units | | | | | Parcel Total Land Area | | | | | Total Land Value | | | | | | | | | | |

| CONSTRUCTION DETAIL | | | | | | CONSTRUCTION DETAIL (CONTINUED) | | | | | |
|--|----------------|----------------|------------|------------|-----------|---------------------------------|------|-------------|------------|-------------|-----|
| Element | Cd | Description | | | | Element | Cd | Description | | | |
| Style | 07 | Modern/Contemp | | | | | | | | | |
| Model | 01 | Residential | | | | | | | | | |
| Grade: | B+ | Custom Plus | | | | | | | | | |
| Stories | 2 | 2 Stories | | | | | | | | | |
| Exterior Wall 1 | 14 | Wood Shingle | | | | CONDO DATA | | | | | |
| Exterior Wall 2 | | | | | | Parcel Id | | C | | Owne | 0.0 |
| Roof Structure | 03 | Gable/Hip | | | | | | B | | S | |
| Roof Cover | 10 | Wood Shingle | | | | Adjust Type | Code | Description | Factor% | | |
| Interior Wall 1 | 05 | Drywall | | | | Condo Flr | | | | | |
| Interior Wall 2 | 02 | Wall Brd/Wood | | | | Condo Unit | | | | | |
| Interior Floor 1 | 14 | Carpet | | | | COST / MARKET VALUATION | | | | | |
| Interior Floor 2 | 12 | Hardwood | | | | Building Value New | | | | | |
| Heat Fuel | 03 | Gas | | | | Year Built | | | | | |
| Heat Type | 04 | Hot Air | | | | Effective Year Built | | | | | |
| AC Type | 03 | Central | | | | Depreciation Code | | | | | |
| Bedrooms | 04 | 4 Bedrooms | | | | Remodel Rating | | | | | |
| Full Baths | 3 | | | | | Year Remodeled | | | | | |
| Half Baths | 2 | | | | | Depreciation % | | | | | |
| Extra Fixtures | | | | | | Functional Obsol | | | | | |
| Total Rooms | 7 | | | | | External Obsol | | | | | |
| Bath Style | | | | | | Trend Factor | | | | | |
| Kitchen Style | | | | | | Condition | | | | | |
| Occupancy | | | | | | Condition % | | | | | |
| Usrflid 105 | | | | | | Percent Good | | | | | |
| Accessory Apt | | | | | | RCNLD | | | | | |
| Foundation Alt | 01 | Poured Conc. | | | | Dep % Ovr | | | | | |
| Rms Prts | | | | | | Dep Ovr Comment | | | | | |
| Bath Split | 32 | 3 Full-2 Half | | | | Misc Imp Ovr | | | | | |
| | | | | | | Misc Imp Ovr Comment | | | | | |
| | | | | | | Cost to Cure Ovr | | | | | |
| | | | | | | Cost to Cure Ovr Comment | | | | | |
| OB - OUTBUILDING & YARD ITEMS(L) / XF - BUILDING EXTRA FEATURES(B) | | | | | | | | | | | |
| Code | Description | L/B | Units | Unit Price | Yr Blt | Cond. Cd | % Gd | Grade | Grade Adj. | Appr. Value | |
| FPLG | Gas Fireplace- | B | 1 | 2500.00 | 2000 | | 84 | | 0.00 | 2,100 | |
| BUILDING SUB-AREA SUMMARY SECTION | | | | | | | | | | | |
| Code | Description | Living Area | Floor Area | Eff Area | Unit Cost | Undeprec Value | | | | | |
| | | | | | | | | | | | |
| Ttl Gross Liv / Lease Area | | | | | | | | | | | |