

CURRENT OWNER		TOPO	UTILITIES	STRT / ROAD	LOCATION	CURRENT ASSESSMENT				801 FY2024 BARNSTABLE, MA VISION	
GRAY, DEBORAH TR IRENE MAHAFFEY LIVING TRUST 3426 MAUI DRIVE CORPUS CHRIS TX 78418		1 Level	2 Public Water	1 Paved		Description	Code	Assessed	Assessed		
			4 Gas			RESIDNTL	1010	422,400	422,400		
			6 Septic			RES LAND	1010	213,100	213,100		
SUPPLEMENTAL DATA						Total				635,500	635,500
Alt Prcl ID Split Zonin BID Parcel ResExpt Q #DL 1 LOT 1 #DL 2 GIS ID F_962572_2691710				Plan Ref. 371/49 Land Ct# #SR Life Estate PP STATU Assoc Pid#							

RECORD OF OWNERSHIP		BK-VOL/PAGE	SALE DATE	Q/U	V/I	SALE PRIC	VC	PREVIOUS ASSESSMENTS (HISTORY)							
GRAY, DEBORAH TR	24422	0133	03-16-2010	U	I	100	1F	Year	Code	Assessed	Year	Code	Assessed		
MAHAFFEY, IRENE G	23031	0315	07-08-2008	U	I	100	1F	2023	1010	336,400	2022	1010	311,600		
MAHAFFEY, IRENE G	23031	0314	07-08-2008	U	I	0	1F		1010	193,800		1010	133,300		
LARSON, PAULINE G & MAHAFFEY, IRENE	4477	0315	04-15-1985	Q	I	225,000	U					1010	4,900		
JANDL, RICHARD L TR ETAL	3893	0129	10-15-1983	U		0		Total		530,200	Total		444,900	Total	405,600

EXEMPTIONS			OTHER ASSESSMENTS				This signature acknowledges a visit by a Data Collector or Assessor				
Year	Code	Description	Amount	Code	Description	Number	Amount	Comm	Int		
Total			0.00								

ASSESSING NEIGHBORHOOD				APPRAISED VALUE SUMMARY			
Nbhd	Nbhd Name	B	Tracing	Batch			
0107				OSTVIL	Appraised Bldg. Value (Card)	367,600	
					Appraised Xf (B) Value (Bldg)	49,900	
					Appraised Ob (B) Value (Bldg)	4,900	
					Appraised Land Value (Bldg)	213,100	
					Special Land Value	0	
					Total Appraised Parcel Value	635,500	
					Valuation Method	C	
					Total Appraised Parcel Value	635,500	

NOTES								VISIT / CHANGE HISTORY						
Permit Id	Issue Date	Type	Description	Amount	Insp Date	% Comp	Date Comp	Comments	Date	Id	Type	Is	Cd	Purpost/Result
201203326	06-06-2012	NR	New Roof	5,700	06-30-2012	100	06-30-2012	REROOF STRIPPING OLD	06-01-2020	WD			FR	Field Review
									02-28-2017	KM	02		03	Cycl Insp Comp
									01-14-2015	AL	03		16	In Office Review
									09-03-2009	MA	22		22	Change of Address
									07-07-2008	MA	22		22	Change of Address
									05-15-2007	PT	02		14	Cyclical Inspection
									04-19-2001	PT	01		00	Meas/Listed-Interior Acces

LAND LINE VALUATION SECTION																	
B	Use Code	Description	Zone	LA	Land Units	Unit Price	Size Adj	AC Disc	Site Index	Cond.	Nbhd.	Nbhd. Adj	Notes	Location Adjustmen	Adj Unit P	Land Value	
1	1010	Single Fam M-0	RC	3	0.350	AC	176,344.00	2.46674	1.0000	5	1.00	0107	1.400		1.0000	608,986.3	213,100
Total Card Land Units					0.35	AC	Parcel Total Land Area					0.35	Total Land Value			213,100	

CONSTRUCTION DETAIL			CONSTRUCTION DETAIL (CONTINUED)		
Element	Cd	Description	Element	Cd	Description
Style	07	Modern/Contemp			
Model	01	Residential			
Grade:	C+	Average Plus			
Stories	1.5	1 1/2 Stories			
Exterior Wall 1	14	Wood Shingle			
Exterior Wall 2	11	Clapboard			
Roof Structure	03	Gable/Hip			
Roof Cover	03	Asph/F Gls/Cmp			
Interior Wall 1	03	Plastered			
Interior Wall 2					
Interior Floor 1	14	Carpet			
Interior Floor 2	12	Hardwood			
Heat Fuel	03	Gas			
Heat Type	05	Hot Water			
AC Type	01	None			
Bedrooms	02	2 Bedrooms			
Full Baths	2				
Half Baths	1				
Extra Fixtures					
Total Rooms	9	9 Rooms			
Bath Style					
Kitchen Style					
Occupancy					
Usrflid 105					
Accessory Apt					
Foundation Alt	01	Poured Conc.			
Rms Prts					
Bath Split	21	2 Full-1 Half			
CONDO DATA			COST / MARKET VALUATION		
Parcel Id		C	Ownr		0.0
Adjust Type	Code	Description	Factor%		
Condo Flr					
Condo Unit					
Building Value New		442,933			
Year Built		1983			
Effective Year Built		1997			
Depreciation Code		A			
Remodel Rating					
Year Remodeled					
Depreciation %		17			
Functional Obsol		0			
External Obsol		0			
Trend Factor		1			
Condition					
Condition %					
Percent Good		83			
RCNLD		367,600			
Dep % Ovr					
Dep Ovr Comment					
Misc Imp Ovr					
Misc Imp Ovr Comment					
Cost to Cure Ovr					
Cost to Cure Ovr Comment					

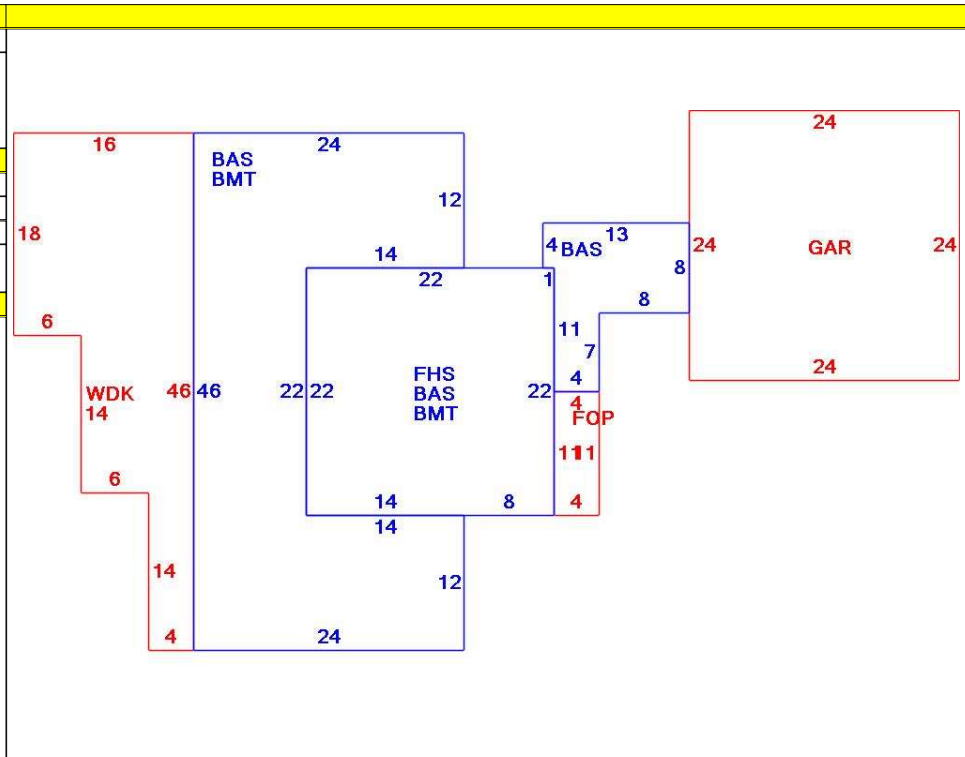

OB - OUTBUILDING & YARD ITEMS(L) / XF - BUILDING EXTRA FEATURES(B)										
Code	Description	L/B	Units	Unit Price	Yr Blt	Cond. Cd	% Gd	Grade	Grade Adj.	Appr. Value
FPL1	Fireplace 1 sto	B	1	5000.00	1999		83		0.00	4,200
WDC	Wood Deck w/	L	484	18.00	1999		60		0.00	4,900
FOP	Open Porch-ro	B	44	55.00	1999		83		0.00	2,600
GAR	Attached Gara	B	576	40.00	1999		83		0.00	17,000
BMT	Basement-Unfi	B	1,280	26.01	1999		83		0.00	26,100

BUILDING SUB-AREA SUMMARY SECTION						
Code	Description	Living Area	Floor Area	Eff Area	Unit Cost	Undeprec Value
BAS	First Floor	1,408	1,408	1,408	268.44	377,969
BMT	Basement Area	0	1,280	0	0.00	0
FHS	Half Story	242	484	242	134.22	64,963
FOP	Open Porch	0	44	0	0.00	0
GAR	Attached Garage	0	576	0	0.00	0
WDK	Wood Deck	0	484	0	0.00	0
Ttl Gross Liv / Lease Area		1,650	4,276	1,650		442,932



2.28.2017