

CURRENT OWNER		TOPO	UTILITIES	STRT / ROAD	LOCATION	CURRENT ASSESSMENT				801 FY2024 BARNSTABLE, MA VISION				
KAYAJAN, JOHN M II & KIMBERLY J	1 Level	6 Septic	1 Paved			Description	Code	Assessed	Assessed					
		4 Gas				RESIDENTL	1010	550,800	550,800					
72 OAK RIDGE ROAD		2 Public Water				RES LAND	1010	476,000	476,000					
SUPPLEMENTAL DATA						Total				1,026,800	1,026,800			
OSTERVILLE MA 02655	Alt Prcl ID	Split Zonin	BID Parcel	ResExpt Q	#DL 1	#DL 2	GIS ID	F_961188_2693363	Plan Ref.	Land Ct#	#SR	Life Estate	PP STATU	Assoc Pid#

RECORD OF OWNERSHIP		BK-VOL/PAGE	SALE DATE	Q/U	V/I	SALE PRIC	VC	PREVIOUS ASSESSMENTS (HISTORY)								
KAYAJAN, JOHN M II & KIMBERLY J	30445	0177	04-26-2017	Q	I	392,000	00	Year	Code	Assessed	Year	Code	Assessed	Year	Code	Assessed
HOSTETTER, DANIEL SR & DANIEL JR T	23197	0266	10-06-2008	U	I	1	1F	2023	1010	477,000	2022	1010	362,500	2021	1010	196,300
HOSTETTER, PRISCILLA M	9922	0120	11-09-1995	U	I	1	A		1010	335,000		1010	284,400		1010	258,500
HOSTETTER, WINNIFRED C ESTATE OF	93P0965	0	08-17-1995	U	I	0	1								1010	39,400
HOSTETTER, RAYMOND E & WINNIFRE	1092	0241	10-03-1960	Q	V	14,400	U	Total		812,000	Total		646,900	Total		494,200

EXEMPTIONS			OTHER ASSESSMENTS					This signature acknowledges a visit by a Data Collector or Assessor							
Year	Code	Description	Amount	Code	Description	Number	Amount	Comm Int							
Total			0.00												

ASSESSING NEIGHBORHOOD				
Nbhd	Nbhd Name	B	Tracing	Batch
0110				OSTVIL

NOTES																																																																																																																																																					
<table border="1"> <thead> <tr> <th colspan="10">BUILDING PERMIT RECORD</th> <th colspan="5">VISIT / CHANGE HISTORY</th> </tr> <tr> <th>Permit Id</th> <th>Issue Date</th> <th>Type</th> <th>Description</th> <th>Amount</th> <th>Insp Date</th> <th>% Comp</th> <th>Date Comp</th> <th>Comments</th> <th>Date</th> <th>Id</th> <th>Type</th> <th>Is</th> <th>Cd</th> <th>Purpost/Result</th> </tr> </thead> <tbody> <tr> <td>20-1711</td> <td>07-30-2020</td> <td>804</td> <td>Addn Alt-Res</td> <td>125,000</td> <td>06-20-2023</td> <td>80</td> <td></td> <td>Remodel - New garage, breez</td> <td>06-20-2023</td> <td>SR</td> <td>02</td> <td></td> <td>13</td> <td>CALL BACK</td> </tr> <tr> <td>20-495</td> <td>04-06-2020</td> <td>830</td> <td>Pool - Inground</td> <td>30,000</td> <td>08-07-2020</td> <td>100</td> <td>06-30-2020</td> <td>construct 16x32x7 steel wall, v</td> <td>07-21-2022</td> <td>SR</td> <td>01</td> <td></td> <td>13</td> <td>CALL BACK</td> </tr> <tr> <td>19-2436</td> <td>04-02-2020</td> <td>822</td> <td>Insulation</td> <td>6,433</td> <td>08-07-2020</td> <td>100</td> <td>08-07-2020</td> <td>Damming, Install 13" layer cell</td> <td>05-06-2022</td> <td>CK</td> <td>02</td> <td></td> <td>13</td> <td>CALL BACK</td> </tr> <tr> <td>20-280</td> <td>01-29-2020</td> <td>889</td> <td></td> <td>0</td> <td>12-31-2008</td> <td>100</td> <td>12-31-2008</td> <td>PERMIT FAILED TO COME IN</td> <td>04-13-2021</td> <td>SR</td> <td>02</td> <td></td> <td>13</td> <td>CALL BACK</td> </tr> <tr> <td></td> <td></td> <td></td> <td></td> <td></td> <td></td> <td></td> <td></td> <td></td> <td>08-07-2020</td> <td>SR</td> <td>02</td> <td></td> <td>02</td> <td>Bldg Permit Completed</td> </tr> <tr> <td></td> <td></td> <td></td> <td></td> <td></td> <td></td> <td></td> <td></td> <td></td> <td>06-01-2020</td> <td>WD</td> <td></td> <td></td> <td></td> <td>FR Field Review</td> </tr> <tr> <td></td> <td></td> <td></td> <td></td> <td></td> <td></td> <td></td> <td></td> <td></td> <td>08-18-2017</td> <td>MS</td> <td>02</td> <td></td> <td>03</td> <td>Cycl Insp Comp</td> </tr> </tbody> </table>															BUILDING PERMIT RECORD										VISIT / CHANGE HISTORY					Permit Id	Issue Date	Type	Description	Amount	Insp Date	% Comp	Date Comp	Comments	Date	Id	Type	Is	Cd	Purpost/Result	20-1711	07-30-2020	804	Addn Alt-Res	125,000	06-20-2023	80		Remodel - New garage, breez	06-20-2023	SR	02		13	CALL BACK	20-495	04-06-2020	830	Pool - Inground	30,000	08-07-2020	100	06-30-2020	construct 16x32x7 steel wall, v	07-21-2022	SR	01		13	CALL BACK	19-2436	04-02-2020	822	Insulation	6,433	08-07-2020	100	08-07-2020	Damming, Install 13" layer cell	05-06-2022	CK	02		13	CALL BACK	20-280	01-29-2020	889		0	12-31-2008	100	12-31-2008	PERMIT FAILED TO COME IN	04-13-2021	SR	02		13	CALL BACK										08-07-2020	SR	02		02	Bldg Permit Completed										06-01-2020	WD				FR Field Review										08-18-2017	MS	02		03	Cycl Insp Comp
BUILDING PERMIT RECORD										VISIT / CHANGE HISTORY																																																																																																																																											
Permit Id	Issue Date	Type	Description	Amount	Insp Date	% Comp	Date Comp	Comments	Date	Id	Type	Is	Cd	Purpost/Result																																																																																																																																							
20-1711	07-30-2020	804	Addn Alt-Res	125,000	06-20-2023	80		Remodel - New garage, breez	06-20-2023	SR	02		13	CALL BACK																																																																																																																																							
20-495	04-06-2020	830	Pool - Inground	30,000	08-07-2020	100	06-30-2020	construct 16x32x7 steel wall, v	07-21-2022	SR	01		13	CALL BACK																																																																																																																																							
19-2436	04-02-2020	822	Insulation	6,433	08-07-2020	100	08-07-2020	Damming, Install 13" layer cell	05-06-2022	CK	02		13	CALL BACK																																																																																																																																							
20-280	01-29-2020	889		0	12-31-2008	100	12-31-2008	PERMIT FAILED TO COME IN	04-13-2021	SR	02		13	CALL BACK																																																																																																																																							
									08-07-2020	SR	02		02	Bldg Permit Completed																																																																																																																																							
									06-01-2020	WD				FR Field Review																																																																																																																																							
									08-18-2017	MS	02		03	Cycl Insp Comp																																																																																																																																							

LAND LINE VALUATION SECTION																	
B	Use Code	Description	Zone	LA	Land Units	Unit Price	Size Adj	AC Disc	Site Index	Cond.	Nbhd.	Nbhd. Adj	Notes	Location Adjustmen	Adj Unit P	Land Value	
1	1010	Single Fam M-0	RC	3	0.390	AC	176,344.00	2.23277	1.0000	5	1.00	0110	3.100		1.0000	1,220,582	476,000
Total Card Land Units					0.39	AC	Parcel Total Land Area					0.39	Total Land Value			476,000	

CONSTRUCTION DETAIL			CONSTRUCTION DETAIL (CONTINUED)		
Element	Cd	Description	Element	Cd	Description
Style	06	Conventional			
Model	01	Residential			
Grade:	C	Average			
Stories	1.75	1 3/4 Stories			
Exterior Wall 1	14	Wood Shingle			
Exterior Wall 2					
RooF Structure	03	Gable/Hip			
RooF Cover	03	Asph/F Gls/Cmp			
Interior Wall 1	05	Drywall			
Interior Wall 2					
Interior Floor 1	12	Hardwood			
Interior Floor 2					
Heat Fuel	03	Gas			
Heat Type	05	Hot Water			
AC Type	01	None			
Bedrooms	04	4 Bedrooms			
Full Baths	3				
Half Baths	0				
Extra Fixtures					
Total Rooms	6	6 Rooms			
Bath Style					
Kitchen Style					
Occupancy					
Usrflid 105					
Accessory Apt					
Foundation Alt	02	Conc. Block			
Rms Prts					
Bath Split	30	3 Full-0 Half			
CONDO DATA					
Parcel Id		C	Owne	0.0	
Adjust Type	Code	Description	Factor%		
Condo Flr					
Condo Unit					
COST / MARKET VALUATION					
Building Value New		608,469			
Year Built		1950			
Effective Year Built		1981			
Depreciation Code		A			
Remodel Rating					
Year Remodeled					
Depreciation %		30			
Functional Obsol		0			
External Obsol		0			
Trend Factor		1			
Condition					
Condition %					
Percent Good		70			
RCNLD		456,200			
Dep % Ovr					
Dep Ovr Comment					
Misc Imp Ovr					
Misc Imp Ovr Comment					
Cost to Cure Ovr					
Cost to Cure Ovr Comment					

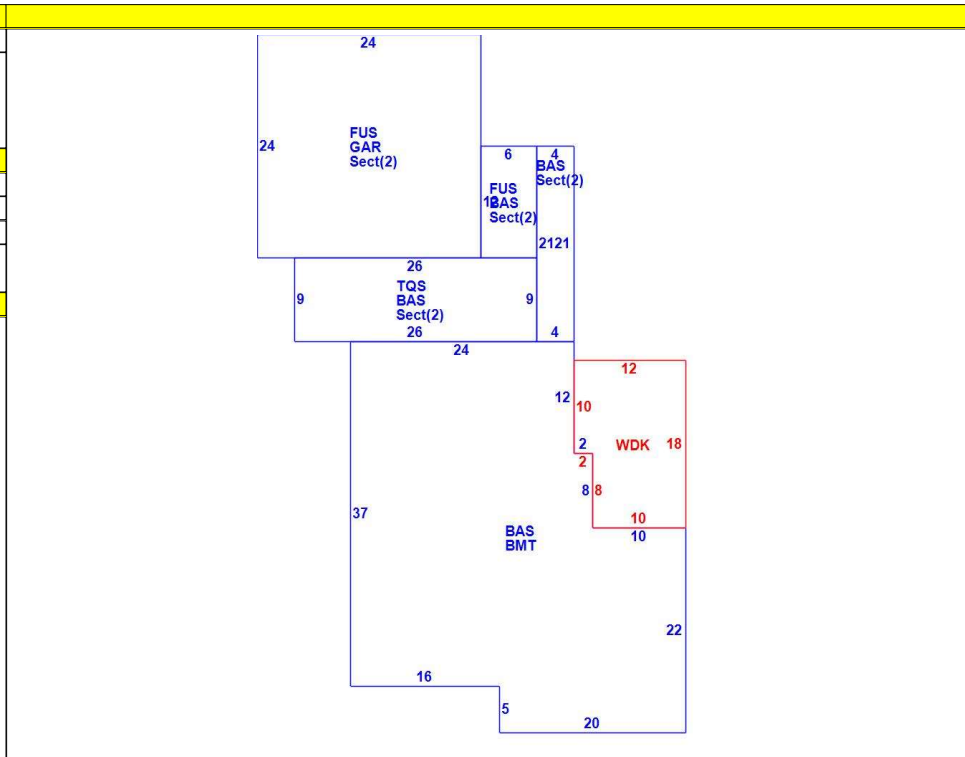

OB - OUTBUILDING & YARD ITEMS(L) / XF - BUILDING EXTRA FEATURES(B)										
Code	Description	L/B	Units	Unit Price	Yr Blt	Cond. Cd	% Gd	Grade	Grade Adj.	Appr. Value
FPL1	Fireplace 1 sto	B	1	5000.00	1983		70		0.00	3,500
BFA	Bsmt Fin-Avg	B	900	17.36	1983		70		0.00	10,900
WDC	Wood Decking	L	200	20.00	1990		42		0.00	2,000
BMT	Basement-Unfi	B	1,208	26.01	1983		70		0.00	21,000
FOP	Open Porch-ro	B	120	55.00	1983		70		0.00	4,400
PATS	Patio-Concrete	L	421	20.00	2020		100		0.00	8,300
SPL2	Pool Vinyl	L	512	55.00	2020		100	C	1.00	28,200

BUILDING SUB-AREA SUMMARY SECTION						
Code	Description	Living Area	Floor Area	Eff Area	Unit Cost	Undeprec Value
BAS	First Floor	1,208	1,208	1,208	253.74	306,518
BMT	Basement Area	0	1,208	0	0.00	0
WDK	Wood Deck	0	200	0	0.00	0
Ttl Gross Liv / Lease Area		1,208	2,616	1,208		306,518



