

CURRENT OWNER				TOPO	UTILITIES	STRT / ROAD	LOCATION	CURRENT ASSESSMENT				
AGRANAT, HOWARD N & SHELIA W T 175 TOWER HILL ROAD REALTY TRU 9170 TORREFINO COURT				1 Level	6 Septic	1 Paved		Description	Code	Assessed	Assessed	801 FY2024 BARNSTABLE, MA VISION
					4 Gas			RESIDNTL	1010	496,300	496,300	
NAPLES FL 34109					2 Public Water			RES LAND	1010	322,700	322,700	
				SUPPLEMENTAL DATA				Alt Prcl ID Split Zonin BID Parcel ResExpt Q #DL 1 #DL 2 GIS ID F_961418_2693057		Plan Ref. 265/7 Land Ct# #SR Life Estate PP STATU Assoc Pid#		

RECORD OF OWNERSHIP				BK-VOL/PAGE	SALE DATE	Q/U	V/I	SALE PRIC	VC	PREVIOUS ASSESSMENTS (HISTORY)					
AGRANAT, HOWARD N & SHELIA W TRS				3255 0281	03-18-1981	U		0		Year	Code	Assessed	Year	Code	Assessed
										2023	1010	422,300	2022	1010	344,000
											1010	300,000		1010	207,400
													2021	1010	306,900
														1010	227,200
														1010	4,400
										Total 722,300		Total 551,400		Total 538,500	

EXEMPTIONS				OTHER ASSESSMENTS			
Year	Code	Description	Amount	Code	Description	Number	Amount
Total			0.00				

ASSESSING NEIGHBORHOOD			
Nbhd	Nbhd Name	B	Tracing
0109			OSTVIL

NOTES			
This signature acknowledges a visit by a Data Collector or Assessor			
APPRAISED VALUE SUMMARY			
Appraised Bldg. Value (Card)			456,900
Appraised Xf (B) Value (Bldg)			35,000
Appraised Ob (B) Value (Bldg)			4,400
Appraised Land Value (Bldg)			322,700
Special Land Value			0
Total Appraised Parcel Value			819,000
Valuation Method			C
Total Appraised Parcel Value			819,000

BUILDING PERMIT RECORD								VISIT / CHANGE HISTORY						
Permit Id	Issue Date	Type	Description	Amount	Insp Date	% Comp	Date Comp	Comments	Date	Id	Type	Is	Cd	Purpost/Result
77458	06-10-2004	AD	Addition	12,000	06-15-2005	100	01-01-2005		06-01-2020	WD			FR	Field Review
19720	01-01-1997	RE	Remodel	75,000	08-25-1998	100		3BED2ND F	08-18-2017	MS	02		03	Cycl Insp Comp
B37042	09-01-1994	AD	Addition	18,000	01-15-1995	100		OS ADD'N	05-23-2007	PT	02		14	Cyclical Inspection
B33970	09-01-1990	AD	Addition	9,000	01-15-1991	100		OS ADD'N	06-15-2005	MF	02		02	Bldg Permit Completed
									12-29-1998	DD	01		00	Meas/Listed-Interior Acces
									08-25-1998	LK				
									05-15-1995	ME	02		01	Meas/Est

LAND LINE VALUATION SECTION																	
B	Use Code	Description	Zone	LA	Land Units	Unit Price	Size Adj	AC Disc	Site Index	Cond.	Nbhd.	Nbhd. Adj	Notes	Location Adjustmen	Adj Unit P	Land Value	
1	1010	Single Fam M-0	RC	3	0.230 AC	176,344.00	3.61599	1.0000	5	1.00	0109	2.200		1.0000	1,402,851	322,700	
Total Card Land Units					0.23 AC	Parcel Total Land Area					0.23	Total Land Value					322,700

CONSTRUCTION DETAIL			CONSTRUCTION DETAIL (CONTINUED)		
Element	Cd	Description	Element	Cd	Description
Style	03	Colonial			
Model	01	Residential			
Grade:	C	Average			
Stories	2	2 Stories			
Exterior Wall 1	14	Wood Shingle			
Exterior Wall 2					
RooF Structure	03	Gable/Hip			
RooF Cover	03	Asph/F Gls/Cmp			
Interior Wall 1	05	Drywall			
Interior Wall 2					
Interior Floor 1	12	Hardwood			
Interior Floor 2					
Heat Fuel	03	Gas			
Heat Type	04	Hot Air			
AC Type	03	Central			
Bedrooms	03	3 Bedrooms			
Full Baths	3				
Half Baths	1				
Extra Fixtures					
Total Rooms	8				
Bath Style					
Kitchen Style					
Occupancy					
Usrflid 105					
Accessory Apt					
Foundation Alt	01	Poured Conc.			
Rms Prts					
Bath Split	31	3 Full-1 Half			
CONDO DATA			COST / MARKET VALUATION		
Parcel Id		C	Ownr	0.0	
Adjust Type	Code	Description	Factor%		
Condo Flr					
Condo Unit					
Building Value New			593,365		
Year Built			1943		
Effective Year Built			1989		
Depreciation Code			VG		
Remodel Rating					
Year Remodeled					
Depreciation %			23		
Functional Obsol			0		
External Obsol			0		
Trend Factor			1		
Condition					
Condition %					
Percent Good			77		
RCNLD			456,900		
Dep % Ovr					
Dep Ovr Comment					
Misc Imp Ovr					
Misc Imp Ovr Comment					
Cost to Cure Ovr					
Cost to Cure Ovr Comment					

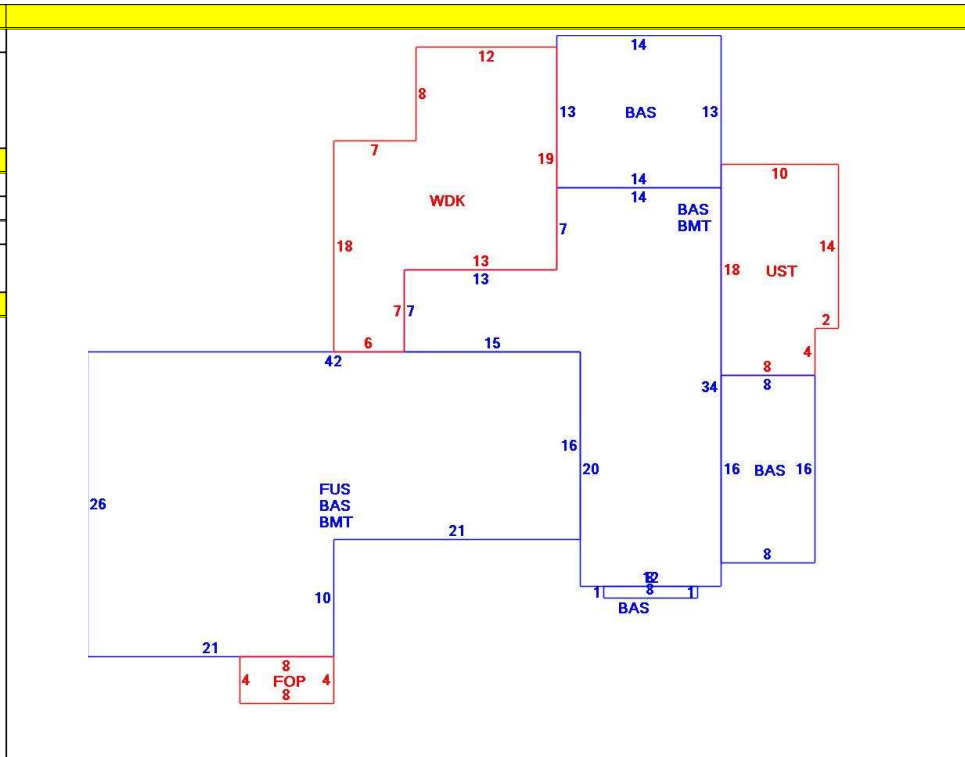

OB - OUTBUILDING & YARD ITEMS(L) / XF - BUILDING EXTRA FEATURES(B)										
Code	Description	L/B	Units	Unit Price	Yr Blt	Cond. Cd	% Gd	Grade	Grade Adj.	Appr. Value
FPL3	Fireplace 2 sto	B	1	7000.00	1989		77		0.00	5,400
WDC	Wood Decking	L	347	20.00	2001		64		0.00	4,400
FOP	Open Porch-ro	B	32	55.00	1989		77		0.00	1,900
UST	Utility Storage-	B	172	17.11	1989		77		0.00	1,600
BMT	Basement-Unfi	B	1,409	26.01	1989		77		0.00	26,100

BUILDING SUB-AREA SUMMARY SECTION						
Code	Description	Living Area	Floor Area	Eff Area	Unit Cost	Undeprec Value
BAS	First Floor	1,727	1,727	1,727	227.43	392,772
BMT	Basement Area	0	1,409	0	0.00	0
FOP	Open Porch	0	32	0	0.00	0
FUS	Upper Story	882	882	882	227.43	200,593
UST	Utility Enclosure	0	172	0	0.00	0
WDK	Wood Deck	0	347	0	0.00	0
Ttl Gross Liv / Lease Area		2,609	4,569	2,609		593,365

