

CURRENT OWNER		TOPO	UTILITIES	STRT / ROAD	LOCATION	CURRENT ASSESSMENT				801 FY2024 BARNSTABLE, MA  <b>VISION</b>	
MCSORLEY, CAROLYN L  117 HINCKLEY CIRCLE  OSTERVILLE MA 02655		1 Level	6 Septic	1 Paved		Description	Code	Assessed	Assessed		
			4 Gas			RESIDNTL	1010	366,400	366,400		
			2 Public Water			RES LAND	1010	322,700	322,700		
<b>SUPPLEMENTAL DATA</b>						Total				689,100	689,100
		Alt Prcl ID	Split Zonin	Plan Ref.	115/125						
		BID Parcel	ResExpt Q	YES:	Land Ct#						
		#DL 1	LOT 12	Life Estate	PP STATU						
		#DL 2		Assoc Pid#							
		GIS ID	F_961852_2693362								

RECORD OF OWNERSHIP		BK-VOL/PAGE	SALE DATE	Q/U	V/I	SALE PRIC	VC	PREVIOUS ASSESSMENTS (HISTORY)									
MCSORLEY, CAROLYN L	28739	0039	03-16-2015	U	I	1	1A	Year	Code	Assessed	Year	Code	Assessed	Year	Code	Assessed	
MCSORLEY, HERBERT L	26643	0220	09-04-2012	U	I	161,000	1A	2023	1010	317,800	2022	1010	273,000	2021	1010	217,200	
MCSORLEY, HERBERT L TR	24827	0184	09-14-2010	U	I	0	1		1010	300,000		1010	207,400		1010	227,200	
MCSORLEY, BARBARA TR	22200	0279	07-20-2007	U	I	1	1A										
MCSORLEY, BARBARA	8875	0202	11-08-1993	U	I	1	F										
Total								617,800		Total		480,400		Total		449,900	

EXEMPTIONS				OTHER ASSESSMENTS				This signature acknowledges a visit by a Data Collector or Assessor										
Year	Code	Description	Amount	Code	Description	Number	Amount	Comm Int										
2017	5C	RESIDENTIAL EXEMPTION	0.00															
Total			0.00															

ASSESSING NEIGHBORHOOD				APPRAISED VALUE SUMMARY													
Nbhd	Nbhd Name	B		Tracing		Batch											
0109						OSTVIL											
NOTES																	
Appraised Bldg. Value (Card) 329,700 Appraised Xf (B) Value (Bldg) 31,200 Appraised Ob (B) Value (Bldg) 5,500 Appraised Land Value (Bldg) 322,700 Special Land Value 0 Total Appraised Parcel Value 689,100 Valuation Method C Total Appraised Parcel Value 689,100																	

BUILDING PERMIT RECORD								VISIT / CHANGE HISTORY							
Permit Id	Issue Date	Type	Description	Amount	Insp Date	% Comp	Date Comp	Comments	Date	Id	Type	Is	Cd	Purpost/Result	
201503093 B16087	05-22-2015 04-01-1973	NW DW	New Windows Dwelling	6,384 0	06-30-2015 01-15-1974	100 100	06-30-2016	REPLACEMENT WINDOWS (OS 1STORY)	06-01-2020 08-17-2017 01-18-2017 05-17-2007 12-25-1998	WD MS GC PT DD	02 03 02 01		FR 03 16 14 00	Field Review Cycl Insp Comp In Office Review Cyclical Inspection Meas/Listed-Interior Acces	

LAND LINE VALUATION SECTION																
B	Use Code	Description	Zone	LA	Land Units	Unit Price	Size Adj	AC Disc	Site Index	Cond.	Nbhd.	Nbhd. Adj	Notes	Location Adjustmen	Adj Unit P	Land Value
1	1010	Single Fam M-0	RC	3	0.230 AC	176,344.00	3.61599	1.0000	5	1.00	0109	2.200		1.0000	1,402,851	322,700
Total Card Land Units					0.23	AC	Parcel Total Land Area					0.23	Total Land Value			322,700

CONSTRUCTION DETAIL			CONSTRUCTION DETAIL (CONTINUED)		
Element	Cd	Description	Element	Cd	Description
Style	01	Ranch			
Model	01	Residential			
Grade:	C	Average			
Stories	1	1 Story			
Exterior Wall 1	14	Wood Shingle			
Exterior Wall 2					
RooF Structure	03	Gable/Hip			
RooF Cover	03	Asph/F Gls/Cmp			
Interior Wall 1	04	Plywood Panel			
Interior Wall 2					
Interior Floor 1	14	Carpet			
Interior Floor 2	12	Hardwood			
Heat Fuel	02	Oil			
Heat Type	05	Hot Water			
AC Type	03	Central			
Bedrooms	04	4 Bedrooms			
Full Baths	2				
Half Baths	0				
Extra Fixtures					
Total Rooms	7	7 Rooms			
Bath Style					
Kitchen Style					
Occupancy					
Usrflid 105					
Accessory Apt					
Foundation Alt	01	Poured Conc.			
Rms Prts					
Bath Split	20	2 Full-0 Half			

CONDO DATA			
Parcel Id		C	Ownr 0.0
		B	S
Adjust Type	Code	Description	Factor%
Condo Flr			
Condo Unit			

COST / MARKET VALUATION	
Building Value New	417,355
Year Built	1973
Effective Year Built	1992
Depreciation Code	A
Remodel Rating	
Year Remodeled	
Depreciation %	21
Functional Obsol	0
External Obsol	0
Trend Factor	1
Condition	
Condition %	
Percent Good	79
RCNLD	329,700
Dep % Ovr	
Dep Ovr Comment	
Misc Imp Ovr	
Misc Imp Ovr Comment	
Cost to Cure Ovr	
Cost to Cure Ovr Comment	

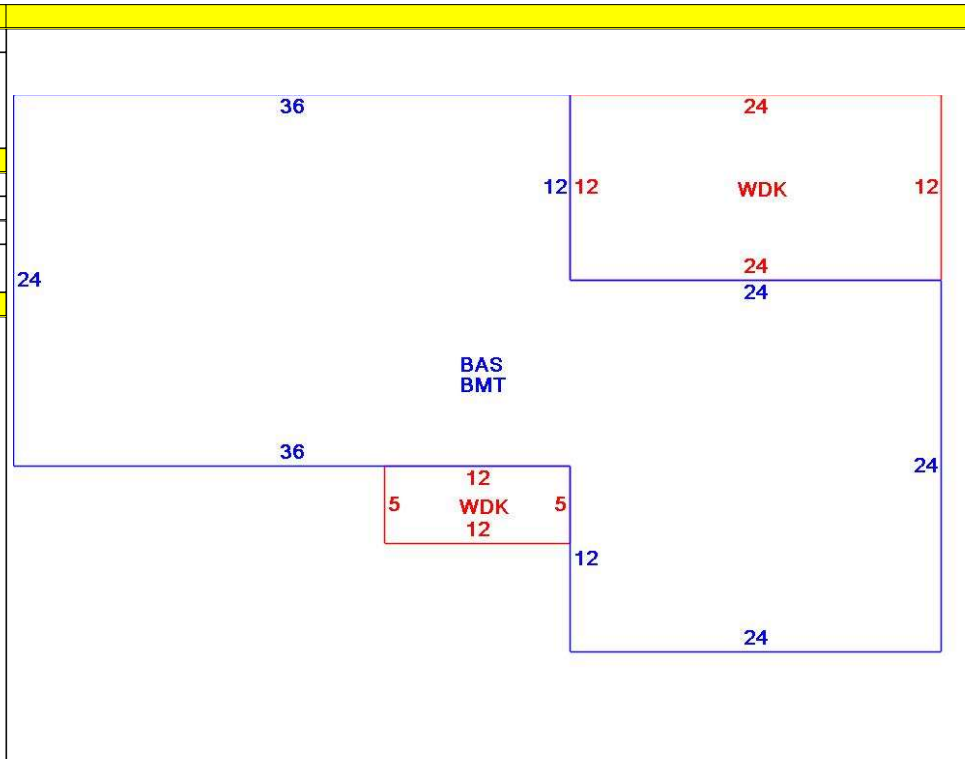

OB - OUTBUILDING & YARD ITEMS(L) / XF - BUILDING EXTRA FEATURES(B)										
Code	Description	L/B	Units	Unit Price	Yr Blt	Cond. Cd	% Gd	Grade	Grade Adj.	Appr. Value
FPL1	Fireplace 1 sto	B	1	5000.00	1994		79		0.00	4,000
WDC	Wood Decking	L	348	20.00	1996		54		0.00	3,700
BMT	Basement-Unfi	B	1,440	26.01	1994		79		0.00	27,200
SHED	Shed	L	100	18.00	2019		100		0.00	1,800

BUILDING SUB-AREA SUMMARY SECTION						
Code	Description	Living Area	Floor Area	Eff Area	Unit Cost	Undeprec Value
BAS	First Floor	1,440	1,440	1,440	289.83	417,355
BMT	Basement Area	0	1,440	0	0.00	0
WDK	Wood Deck	0	348	0	0.00	0
Ttl Gross Liv / Lease Area		1,440	3,228	1,440		417,355

