

| CURRENT OWNER | | TOPO | UTILITIES | STRT / ROAD | LOCATION | CURRENT ASSESSMENT | | | |
|---|--|-------------|----------------|------------------|----------|--------------------|------|----------|----------|
| FORD, CHRISTOPHER C TR FORD IRREVOCABLE TRUST 21 HIBBARD ROAD NEWTON CORN MA 02458 | | 1 Level | 2 Public Water | 1 Paved | | Description | Code | Assessed | Assessed |
| | | | 4 Gas | | | RESIDNTL | 1010 | 403,800 | 403,800 |
| | | | 6 Septic | | | RES LAND | 1010 | 333,500 | 333,500 |
| SUPPLEMENTAL DATA | | | | | | | | | |
| Alt Prcl ID | | Split Zonin | | Plan Ref. | | | | | |
| #DL 1 LOT 55 | | #DL 2 | | Land Ct# 18366-I | | | | | |
| GIS ID F_963587_2693121 | | Assoc Pid# | | | | | | | |
| | | | | | | Total | | 737,300 | 737,300 |

801
 FY2024
 BARNSTABLE, MA

VISION

| RECORD OF OWNERSHIP | | BK-VOL/PAGE | SALE DATE | Q/U | V/I | SALE PRIC | VC | PREVIOUS ASSESSMENTS (HISTORY) | | | | | | | | |
|-------------------------------|---------|-------------|------------|-----|-----|-----------|----|--------------------------------|------|----------|-------|------|----------|-------|--|---------|
| FORD, CHRISTOPHER C TR | C201187 | 0 | 08-16-2013 | U | I | 1 | 1F | Year | Code | Assessed | Year | Code | Assessed | | | |
| FORD, ANTHONY F & CAROLYN B | C157449 | 0 | 04-28-2000 | Q | I | 299,000 | 00 | 2023 | 1010 | 349,300 | 2022 | 1010 | 307,000 | | | |
| MILEFF, EDWARD & SYLVIA J | C129802 | 0 | 04-15-1993 | Q | I | 165,875 | U | | 1010 | 310,100 | | 1010 | 214,400 | | | |
| SVIRSKY, ALDONA B | #D42582 | 0 | 04-09-1987 | U | | 0 | | | | 0 | | 1010 | 2,500 | | | |
| SVIRSKY, MICHAEL B & ALDONA B | C56107 | 0 | 09-19-1972 | U | | 0 | | | | 0 | | | | | | |
| | | | | | | | | Total | | 659,400 | Total | | 521,400 | Total | | 486,600 |

| EXEMPTIONS | | | OTHER ASSESSMENTS | | | | | |
|------------|------|-------------|-------------------|------|-------------|--------|--------|----------|
| Year | Code | Description | Amount | Code | Description | Number | Amount | Comm Int |
| | | | | | | | | |
| Total | | | 0.00 | | | | | |

This signature acknowledges a visit by a Data Collector or Assessor

| ASSESSING NEIGHBORHOOD | | | |
|------------------------|-----------|---|---------|
| Nbhd | Nbhd Name | B | Tracing |
| 0109 | | | OSTVIL |

| APPRAISED VALUE SUMMARY | |
|-------------------------------|---------|
| Appraised Bldg. Value (Card) | 342,800 |
| Appraised Xf (B) Value (Bldg) | 58,500 |
| Appraised Ob (B) Value (Bldg) | 2,500 |
| Appraised Land Value (Bldg) | 333,500 |
| Special Land Value | 0 |
| Total Appraised Parcel Value | 737,300 |
| Valuation Method | C |
| Total Appraised Parcel Value | 737,300 |

| BUILDING PERMIT RECORD | | | | | | | | VISIT / CHANGE HISTORY | | | | | | |
|------------------------|--------------------------|----------|-----------------------|--------|--------------------------|----------|------------|------------------------|--|----------------------|----------------|----|----------------------|---|
| Permit Id | Issue Date | Type | Description | Amount | Insp Date | % Comp | Date Comp | Comments | Date | Id | Type | Is | Cd | Purpost/Result |
| 201202461 39405 | 04-30-2012 06-28-1999 | EX NS | Expired New Siding | 6,000 | 03-31-2016 04-20-2000 | 0 100 | 01-01-2000 | EX-AC UNIT | 06-02-2020 08-21-2017 05-25-2007 06-06-1997 | WD MS PT LK | 02 02 01 | | FR 03 14 00 | Field Review Cycl Insp Comp Cyclical Inspection Meas/Listed-Interior Acces |

| LAND LINE VALUATION SECTION | | | | | | | | | | | | | | | | | |
|-----------------------------|----------|----------------|------|----|------------|------------------------|----------|---------|------------|-------|-------|------------------|-------|--------------------|------------|------------|---------|
| B | Use Code | Description | Zone | LA | Land Units | Unit Price | Size Adj | AC Disc | Site Index | Cond. | Nbhd. | Nbhd. Adj | Notes | Location Adjustmen | Adj Unit P | Land Value | |
| 1 | 1010 | Single Fam M-0 | RC | 3 | 0.330 AC | 176,344.00 | 2.60499 | 1.0000 | 5 | 1.00 | 0109 | 2.200 | | 1.0000 | 1,010,627 | 333,500 | |
| Total Card Land Units | | | | | 0.33 AC | Parcel Total Land Area | | | | | 0.33 | Total Land Value | | | | | 333,500 |

| CONSTRUCTION DETAIL | | | CONSTRUCTION DETAIL (CONTINUED) | | |
|---------------------|----|----------------|---------------------------------|----|-------------|
| Element | Cd | Description | Element | Cd | Description |
| Style | 01 | Ranch | | | |
| Model | 01 | Residential | | | |
| Grade: | C | Average | | | |
| Stories | 1 | 1 Story | | | |
| Exterior Wall 1 | 14 | Wood Shingle | | | |
| Exterior Wall 2 | | | | | |
| RooF Structure | 03 | Gable/Hip | | | |
| RooF Cover | 03 | Asph/F Gls/Cmp | | | |
| Interior Wall 1 | 05 | Drywall | | | |
| Interior Wall 2 | | | | | |
| Interior Floor 1 | 14 | Carpet | | | |
| Interior Floor 2 | | | | | |
| Heat Fuel | 02 | Oil | | | |
| Heat Type | 05 | Hot Water | | | |
| AC Type | 03 | Central | | | |
| Bedrooms | 03 | 3 Bedrooms | | | |
| Full Baths | 2 | | | | |
| Half Baths | 0 | | | | |
| Extra Fixtures | | | | | |
| Total Rooms | 7 | 7 Rooms | | | |
| Bath Style | | | | | |
| Kitchen Style | | | | | |
| Occupancy | | | | | |
| UsrflD 105 | | | | | |
| Accessory Apt | | | | | |
| Foundation Alt | 01 | Poured Conc. | | | |
| Rms Prts | | | | | |
| Bath Split | 20 | 2 Full-0 Half | | | |

| CONDO DATA | | | |
|--------------------------|------|-------------|---------|
| Parcel Id | C | Owne | 0.0 |
| Adjust Type | Code | Description | Factor% |
| | | | |
| Condo Flr | | | |
| Condo Unit | | | |
| COST / MARKET VALUATION | | | |
| Building Value New | | 428,559 | |
| Year Built | | 1974 | |
| Effective Year Built | | 1993 | |
| Depreciation Code | | A | |
| Remodel Rating | | | |
| Year Remodeled | | | |
| Depreciation % | | 20 | |
| Functional Obsol | | 0 | |
| External Obsol | | 0 | |
| Trend Factor | | 1 | |
| Condition | | | |
| Condition % | | | |
| Percent Good | | 80 | |
| RCNLD | | 342,800 | |
| Dep % Ovr | | | |
| Dep Ovr Comment | | | |
| Misc Imp Ovr | | | |
| Misc Imp Ovr Comment | | | |
| Cost to Cure Ovr | | | |
| Cost to Cure Ovr Comment | | | |

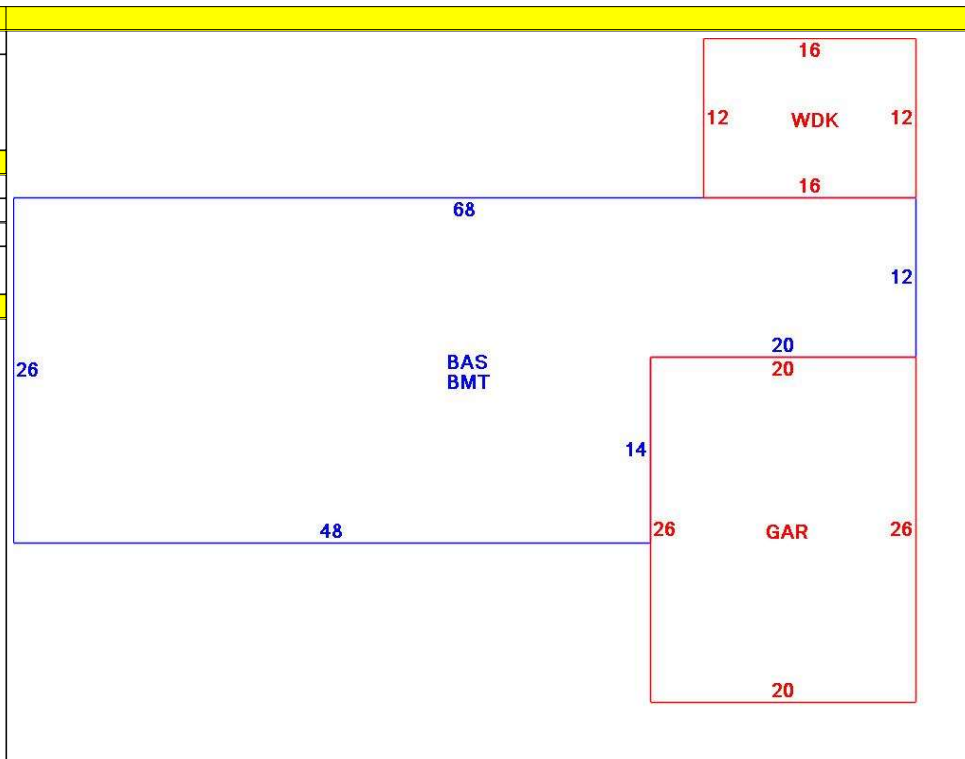

| OB - OUTBUILDING & YARD ITEMS(L) / XF - BUILDING EXTRA FEATURES(B) | | | | | | | | | | |
|--|-----------------|-----|-------|------------|--------|----------|------|-------|------------|-------------|
| Code | Description | L/B | Units | Unit Price | Yr Blt | Cond. Cd | % Gd | Grade | Grade Adj. | Appr. Value |
| BFA | Bsmt Fin-Avg | B | 800 | 17.36 | 1995 | | 80 | | 0.00 | 11,100 |
| FPL1 | Fireplace 1 sto | B | 1 | 5000.00 | 1995 | | 80 | | 0.00 | 4,000 |
| WDC | Wood Decking | L | 192 | 20.00 | 1996 | | 54 | | 0.00 | 2,500 |
| GAR | Attached Gara | B | 520 | 40.00 | 1995 | | 80 | | 0.00 | 15,200 |
| BMT | Basement-Unfi | B | 1,488 | 26.01 | 1995 | | 80 | | 0.00 | 28,200 |

| BUILDING SUB-AREA SUMMARY SECTION | | | | | | |
|-----------------------------------|-----------------|-------------|------------|----------|-----------|----------------|
| Code | Description | Living Area | Floor Area | Eff Area | Unit Cost | Undeprec Value |
| BAS | First Floor | 1,488 | 1,488 | 1,488 | 288.01 | 428,559 |
| BMT | Basement Area | 0 | 1,488 | 0 | 0.00 | 0 |
| GAR | Attached Garage | 0 | 520 | 0 | 0.00 | 0 |
| WDK | Wood Deck | 0 | 192 | 0 | 0.00 | 0 |
| Ttl Gross Liv / Lease Area | | 1,488 | 3,688 | 1,488 | | 428,559 |

