

CURRENT OWNER		TOPO	UTILITIES	STRT / ROAD	LOCATION	CURRENT ASSESSMENT				801 FY2024 BARNSTABLE, MA	
MERRIGAN, GERALD F 164 EVANS STREET OSTERVILLE MA 02655		1 Level	2 Public Water	1 Paved		Description	Code	Assessed	Assessed		
			4 Gas			RESIDNTL	1010	428,400	428,400		
			6 Septic			RES LAND	1010	333,500	333,500		
SUPPLEMENTAL DATA						Total				761,900	761,900
Alt Prcl ID Split Zonin BID Parcel ResExpt Q YES: #DL 1 LOT 61 #DL 2 GIS ID F_963613_2693689				Plan Ref. Land Ct# 18366-J #SR Life Estate PP STATU Assoc Pid#							

VISION

RECORD OF OWNERSHIP		BK-VOL/PAGE	SALE DATE	Q/U	V/I	SALE PRIC	VC	PREVIOUS ASSESSMENTS (HISTORY)								
Year	Code	Assessed	Year	Code	Assessed	Year	Code	Assessed	Year	Code	Assessed					
MERRIGAN, GERALD F	C223176	0	07-29-2020	U	I	1	1F	2023	1010	384,900	2022	1010	323,800	2021	1010	277,600
MERRIGAN, GERALD F & PRISCILLA A	C214606	0	11-07-2017	U	I	526,500	1		1010	310,100						234,800
KENT, BARBARA L ESTATE OF	D133386	0	11-18-2016	U	I											2,500
KENT, BARBARA L	#D66688	0	05-28-1996	U	I		A									
KENT, ROBERT R & BARBARA L	C116332	0	12-20-1988	U	I		A									
Total								695,000	Total		538,200	Total		514,900		

EXEMPTIONS				OTHER ASSESSMENTS			
Year	Code	Description	Amount	Code	Description	Number	Amount
2020	5C	RESIDENTIAL EXEMPTION	0.00				
Total			0.00				

This signature acknowledges a visit by a Data Collector or Assessor

ASSESSING NEIGHBORHOOD			
Nbhd	Nbhd Name	B	Tracing
0109			OSTVIL

APPRAISED VALUE SUMMARY	
Appraised Bldg. Value (Card)	379,600
Appraised Xf (B) Value (Bldg)	46,300
Appraised Ob (B) Value (Bldg)	2,500
Appraised Land Value (Bldg)	333,500
Special Land Value	0
Total Appraised Parcel Value	761,900
Valuation Method	C
Total Appraised Parcel Value	761,900

NOTES							

BUILDING PERMIT RECORD								VISIT / CHANGE HISTORY						
Permit Id	Issue Date	Type	Description	Amount	Insp Date	% Comp	Date Comp	Comments	Date	Id	Type	Is	Cd	Purpost/Result
201105214	10-06-2011	IN	Insulation	2,864	06-30-2012	100	06-30-2012	AIR SEAL-WEATHERIZE-INS	05-14-2021	JD	03		16	In Office Review
									04-14-2021	JD	03		16	In Office Review
									06-02-2020	WD			FR	Field Review
									02-25-2020	PK	03		16	In Office Review
									12-07-2017	LH	03		16	In Office Review
									08-22-2017	MS	02		03	Cycl Insp Comp
									07-09-2014	JR	03		16	In Office Review

LAND LINE VALUATION SECTION																	
B	Use Code	Description	Zone	LA	Land Units	Unit Price	Size Adj	AC Disc	Site Index	Cond.	Nbhd.	Nbhd. Adj	Notes	Location Adjustmen	Adj Unit P	Land Value	
1	1010	Single Fam M-0	RC	3	0.330	AC	176,344.00	2.60499	1.0000	5	1.00	0109	2.200		1.0000	1,010,627	333,500
Total Card Land Units					0.33	AC	Parcel Total Land Area					0.33	Total Land Value			333,500	

CONSTRUCTION DETAIL			CONSTRUCTION DETAIL (CONTINUED)		
Element	Cd	Description	Element	Cd	Description
Style	04	Cape Cod			
Model	01	Residential			
Grade:	C	Average			
Stories	1.75	1 3/4 Stories			
Exterior Wall 1	14	Wood Shingle			
Exterior Wall 2	13	T111 Siding			
Roof Structure	03	Gable/Hip			
Roof Cover	03	Asph/F Gls/Cmp			
Interior Wall 1	05	Drywall			
Interior Wall 2					
Interior Floor 1	12	Hardwood			
Interior Floor 2	14	Carpet			
Heat Fuel	03	Gas			
Heat Type	05	Hot Water			
AC Type	01	None			
Bedrooms	03	3 Bedrooms			
Full Baths	2				
Half Baths	1				
Extra Fixtures					
Total Rooms	6	6 Rooms			
Bath Style					
Kitchen Style					
Occupancy					
Usrflid 105					
Accessory Apt					
Foundation Alt	01	Poured Conc.			
Rms Prts					
Bath Split	21	2 Full-1 Half			

CONDO DATA				
Parcel Id		C	Owne	0.0
Adjust Type	Code	Description	Factor%	
Condo Flr				
Condo Unit				

COST / MARKET VALUATION	
Building Value New	462,967
Year Built	1981
Effective Year Built	1996
Depreciation Code	A
Remodel Rating	
Year Remodeled	
Depreciation %	18
Functional Obsol	0
External Obsol	0
Trend Factor	1
Condition	
Condition %	
Percent Good	82
RCNLD	379,600
Dep % Ovr	
Dep Ovr Comment	
Misc Imp Ovr	
Misc Imp Ovr Comment	
Cost to Cure Ovr	
Cost to Cure Ovr Comment	

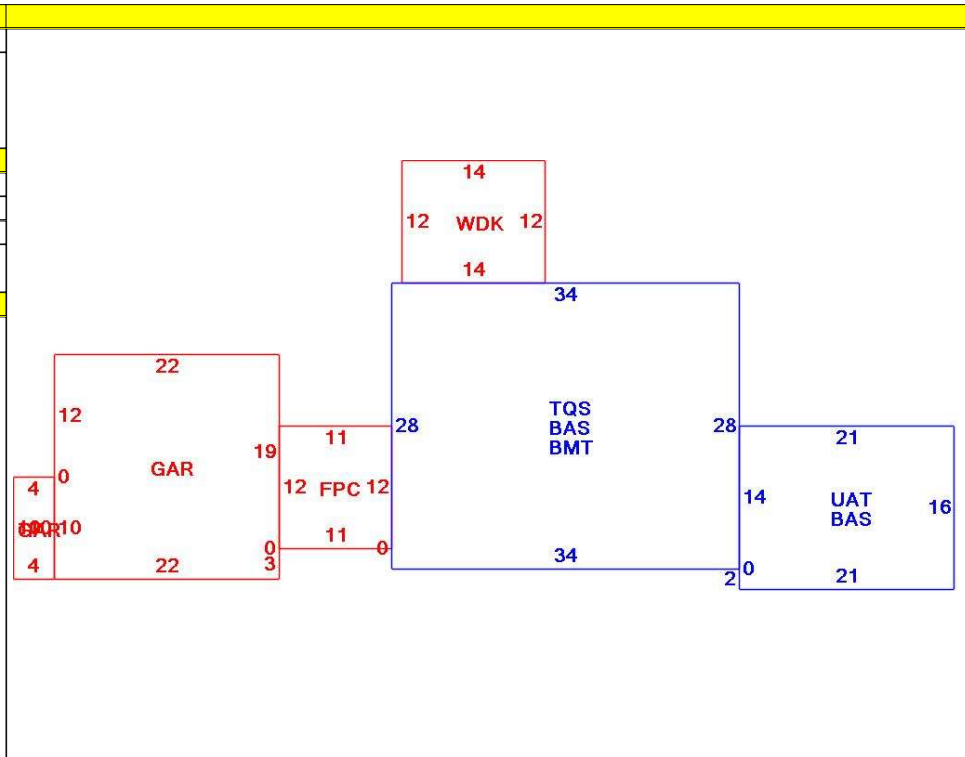

OB - OUTBUILDING & YARD ITEMS(L) / XF - BUILDING EXTRA FEATURES(B)										
Code	Description	L/B	Units	Unit Price	Yr Blt	Cond. Cd	% Gd	Grade	Grade Adj.	Appr. Value
FPL2	Fireplace 1.5 s	B	1	6000.00	1998		82		0.00	4,900
WDC	Wood Decking	L	168	20.00	1998		58		0.00	2,500
FOPC	Open Prch-roo	B	132	55.00	1998		82		0.00	4,600
GAR	Attached Gara	B	524	40.00	1998		82		0.00	15,700
BMT	Basement-Unfi	B	952	26.01	1998		82		0.00	21,100

BUILDING SUB-AREA SUMMARY SECTION						
Code	Description	Living Area	Floor Area	Eff Area	Unit Cost	Undeprec Value
BAS	First Floor	1,288	1,288	1,288	238.52	307,214
BMT	Basement Area	0	952	0	0.00	0
FPC	Open Porch Conc. Floor	0	132	0	0.00	0
GAR	Attached Garage	0	524	0	0.00	0
TQS	Three Quarter Story	619	952	619	155.09	147,644
UAT	Attic, Unfinished	0	336	34	24.14	8,110
WDK	Wood Deck	0	168	0	0.00	0
Ttl Gross Liv / Lease Area		1,907	4,352	1,941		462,968

