

| CURRENT OWNER  |  | TOPO      | UTILITIES      | STRT / ROAD  | LOCATION | CURRENT ASSESSMENT |      |          |          | 801<br>FY2024<br>BARNSTABLE, MA<br><br><b>VISION</b> |         |
|--|--|-----------|----------------|--|----------|--------------------|------|----------|----------|--|---------|
| MACMILLAN, AUDREY L<br><br>139 FALLING LEAF LANE<br><br>OSTERVILLE MA 02655                                    |  | 1 Sloping | 2 Public Water | 1 Paved  |          | Description        | Code | Assessed | Assessed |  |         |
|  |  |           | 4 Gas          |  |          | RESIDNTL           | 1010 | 656,700  | 656,700  |  |         |
|  |  |           | 6 Septic       |  |          | RES LAND           | 1010 | 258,800  | 258,800  |  |         |
| <b>SUPPLEMENTAL DATA</b>   |  |           |                |  |          | Total              |      |          |          | 915,500  | 915,500 |
| Alt Prcl ID<br>Split Zonin<br>BID Parcel<br>ResExpt Q YES:<br>#DL 1 LOT 13<br>#DL 2<br>GIS ID F_962153_2698300 |  |           |                | Plan Ref. 338/22<br>Land Ct#<br>#SR<br>Life Estate<br>PP STATU<br>Assoc Pid# |          |                    |      |          |          |  |         |

| RECORD OF OWNERSHIP          |  | BK-VOL/PAGE | SALE DATE  | Q/U | V/I | SALE PRIC | VC | PREVIOUS ASSESSMENTS (HISTORY) |      |          |       |      |          |       |      |          |
|------------------------------|--|-------------|------------|-----|-----|-----------|----|--------------------------------|------|----------|-------|------|----------|-------|------|----------|
| MACMILLAN, AUDREY L          |  | 35199 341   | 06-21-2022 | U   | I   | 1         | 1F | Year                           | Code | Assessed | Year  | Code | Assessed | Year  | Code | Assessed |
| MACMILLAN, DONALD A & AUDREY |  | 12338 0187  | 06-15-1999 | Q   | V   | 94,900    | 1P | 2023                           | 1010 | 572,600  | 2022  | 1010 | 495,500  | 2021  | 1010 | 399,100  |
| MCSHANE CONSTRUCTION CO INC  |  | 11979 0311  | 01-08-1999 | U   | V   | 55,500    | 1  |                                | 1010 | 256,100  |       | 1010 | 164,000  |       | 1010 | 174,300  |
| O R E ASSOCIATES INC         |  | 7994 0141   | 04-29-1992 | U   | V   | 5,000     | N  |                                |      |          |       |      |          |       | 1010 | 9,400    |
| CASEY, FRANCIS W TR          |  | 7653 0233   | 08-23-1991 | U   | V   | 100       | B  | Total                          |      | 828,700  | Total |      | 659,500  | Total |      | 582,800  |

| EXEMPTIONS |      |                       |        | OTHER ASSESSMENTS |             |        |        | This signature acknowledges a visit by a Data Collector or Assessor |  |  |  |  |  |  |  |  |
|------------|------|-----------------------|--------|-------------------|-------------|--------|--------|---|--|--|--|--|--|--|--|--|
| Year       | Code | Description           | Amount | Code              | Description | Number | Amount | Comm Int  |  |  |  |  |  |  |  |  |
| 2011       | 5C   | RESIDENTIAL EXEMPTION | 0.00   |                   |             |        |        |   |  |  |  |  |  |  |  |  |
| Total      |      |                       | 0.00   |                   |             |        |        |   |  |  |  |  |  |  |  |  |

| ASSESSING NEIGHBORHOOD |           |   |         | APPRAISED VALUE SUMMARY |                               |         |  |
|------------------------|-----------|---|---------|-------------------------|-------------------------------|---------|--|
| Nbhd                   | Nbhd Name | B | Tracing | Batch                   |                               |         |  |
| 0108                   |           |   |         | OSTVIL                  | Appraised Bldg. Value (Card)  | 568,000 |  |
|                        |           |   |         |                         | Appraised Xf (B) Value (Bldg) | 79,300  |  |
|                        |           |   |         |                         | Appraised Ob (B) Value (Bldg) | 9,400   |  |
|                        |           |   |         |                         | Appraised Land Value (Bldg)   | 258,800 |  |
|                        |           |   |         |                         | Special Land Value            | 0       |  |
|                        |           |   |         |                         | Total Appraised Parcel Value  | 915,500 |  |
|                        |           |   |         |                         | Valuation Method              | C       |  |
|                        |           |   |         |                         | Total Appraised Parcel Value  | 915,500 |  |

| NOTES |  |  |  |  |  |  |  | VISIT / CHANGE HISTORY |    |      |    |    |                            |  |  |  |
|-------|--|--|--|--|--|--|--|------------------------|----|------|----|----|----------------------------|--|--|--|
|       |  |  |  |  |  |  |  | Date                   | Id | Type | Is | Cd | Purpost/Result             |  |  |  |
|       |  |  |  |  |  |  |  | 05-27-2020             | LS |      |    | FR | Field Review               |  |  |  |
|       |  |  |  |  |  |  |  | 05-18-2020             | DM |      |    | FR | Field Review               |  |  |  |
|       |  |  |  |  |  |  |  | 08-30-2016             | KM | 02   |    | 03 | Cycl Insp Comp             |  |  |  |
|       |  |  |  |  |  |  |  | 06-06-2007             | PT | 02   |    | 14 | Cyclical Inspection        |  |  |  |
|       |  |  |  |  |  |  |  | 05-23-2000             | MF | 01   |    | 00 | Meas/Listed-Interior Acces |  |  |  |

| BUILDING PERMIT RECORD |            |      |             |         |            |        |            | LAND LINE VALUATION SECTION |   |          |                |      |    |            |            |            |         |            |       |       |           |       |                    |            |            |         |
|------------------------|------------|------|-------------|---------|------------|--------|------------|-----------------------------|---|----------|----------------|------|----|------------|------------|------------|---------|------------|-------|-------|-----------|-------|--------------------|------------|------------|---------|
| Permit Id              | Issue Date | Type | Description | Amount  | Insp Date  | % Comp | Date Comp  | Comments                    | B | Use Code | Description    | Zone | LA | Land Units | Unit Price | Size Adj   | AC Disc | Site Index | Cond. | Nbhd. | Nbhd. Adj | Notes | Location Adjustmen | Adj Unit P | Land Value |         |
| 38772                  | 06-01-2000 | DW   | Dwelling    | 200,000 | 05-23-2000 | 100    | 01-01-2000 |                             | 1 | 1010     | Single Fam M-0 | RC   | 3  | 0.350      | AC         | 176,344.00 | 2.46674 | 1.0000     | 5     | 1.00  | 0108      | 1.700 |                    | 1.0000     | 739,498.5  | 258,800 |

|                       |  |  |  |  |  |  |  |  |  |  |  |  |  |      |    |                        |  |  |  |  |  |  |  |  |  |  |  |  |  |      |                  |  |  |  |  |  |  |  |  |  |  |  |  |  |         |
|-----------------------|--|--|--|--|--|--|--|--|--|--|--|--|--|------|----|------------------------|--|--|--|--|--|--|--|--|--|--|--|--|--|------|------------------|--|--|--|--|--|--|--|--|--|--|--|--|--|---------|
| Total Card Land Units |  |  |  |  |  |  |  |  |  |  |  |  |  | 0.35 | AC | Parcel Total Land Area |  |  |  |  |  |  |  |  |  |  |  |  |  | 0.35 | Total Land Value |  |  |  |  |  |  |  |  |  |  |  |  |  | 258,800 |
|-----------------------|--|--|--|--|--|--|--|--|--|--|--|--|--|------|----|------------------------|--|--|--|--|--|--|--|--|--|--|--|--|--|------|------------------|--|--|--|--|--|--|--|--|--|--|--|--|--|---------|

| CONSTRUCTION DETAIL      |    |                | CONSTRUCTION DETAIL (CONTINUED) |         |             |
|--------------------------|----|----------------|---------------------------------|---------|-------------|
| Element                  | Cd | Description    | Element                         | Cd      | Description |
| Style                    | 01 | Ranch          |                                 |         |             |
| Model                    | 01 | Residential    |                                 |         |             |
| Grade:                   | C+ | Average Plus   |                                 |         |             |
| Stories                  | 1  | 1 Story        |                                 |         |             |
| Exterior Wall 1          | 14 | Wood Shingle   |                                 |         |             |
| Exterior Wall 2          | 11 | Clapboard      |                                 |         |             |
| RooF Structure           | 03 | Gable/Hip      |                                 |         |             |
| RooF Cover               | 03 | Asph/F Gls/Cmp |                                 |         |             |
| Interior Wall 1          | 03 | Plastered      |                                 |         |             |
| Interior Wall 2          |    |                |                                 |         |             |
| Interior Floor 1         | 12 | Hardwood       |                                 |         |             |
| Interior Floor 2         |    |                |                                 |         |             |
| Heat Fuel                | 03 | Gas            |                                 |         |             |
| Heat Type                | 05 | Hot Water      |                                 |         |             |
| AC Type                  | 03 | Central        |                                 |         |             |
| Bedrooms                 | 03 | 3 Bedrooms     |                                 |         |             |
| Full Baths               | 2  |                |                                 |         |             |
| Half Baths               | 1  |                |                                 |         |             |
| Extra Fixtures           |    |                |                                 |         |             |
| Total Rooms              | 7  | 7 Rooms        |                                 |         |             |
| Bath Style               |    |                |                                 |         |             |
| Kitchen Style            |    |                |                                 |         |             |
| Occupancy                |    |                |                                 |         |             |
| Usrflid 105              |    |                |                                 |         |             |
| Accessory Apt            |    |                |                                 |         |             |
| Foundation Alt           | 01 | Poured Conc.   |                                 |         |             |
| Rms Prts                 |    |                |                                 |         |             |
| Bath Split               | 21 | 2 Full-1 Half  |                                 |         |             |
|                          |    |                | <b>CONDO DATA</b>               |         |             |
| Parcel Id                |    |                | C                               | Owne    | 0.0         |
| Adjust Type              |    | Code           | Description                     | Factor% |             |
| Condo Flr                |    |                |                                 |         |             |
| Condo Unit               |    |                |                                 |         |             |
|                          |    |                | <b>COST / MARKET VALUATION</b>  |         |             |
| Building Value New       |    |                |                                 | 638,190 |             |
| Year Built               |    |                |                                 | 1999    |             |
| Effective Year Built     |    |                |                                 | 2005    |             |
| Depreciation Code        |    |                |                                 | A       |             |
| Remodel Rating           |    |                |                                 |         |             |
| Year Remodeled           |    |                |                                 |         |             |
| Depreciation %           |    |                |                                 | 11      |             |
| Functional Obsol         |    |                |                                 | 0       |             |
| External Obsol           |    |                |                                 | 0       |             |
| Trend Factor             |    |                |                                 | 1       |             |
| Condition                |    |                |                                 |         |             |
| Condition %              |    |                |                                 |         |             |
| Percent Good             |    |                |                                 | 89      |             |
| RCNLD                    |    |                |                                 | 568,000 |             |
| Dep % Ovr                |    |                |                                 |         |             |
| Dep Ovr Comment          |    |                |                                 |         |             |
| Misc Imp Ovr             |    |                |                                 |         |             |
| Misc Imp Ovr Comment     |    |                |                                 |         |             |
| Cost to Cure Ovr         |    |                |                                 |         |             |
| Cost to Cure Ovr Comment |    |                |                                 |         |             |

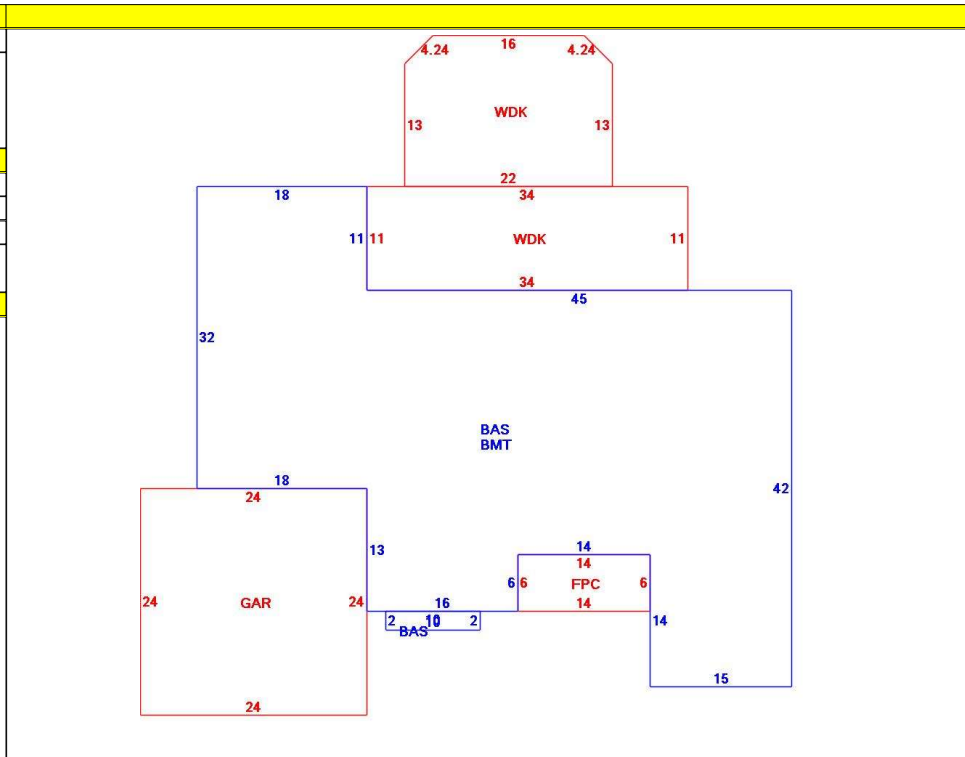

| OB - OUTBUILDING & YARD ITEMS(L) / XF - BUILDING EXTRA FEATURES(B) |                |     |       |            |        |          |      |       |            |             |
|--|----------------|-----|-------|------------|--------|----------|------|-------|------------|-------------|
| Code   | Description    | L/B | Units | Unit Price | Yr Blt | Cond. Cd | % Gd | Grade | Grade Adj. | Appr. Value |
| FPLG   | Gas Fireplace- | B   | 1     | 2500.00    | 2007   |          | 89   |       | 0.00       | 2,200       |
| BFA  | Bsmt Fin-Avg   | B   | 850   | 17.36      | 2007   |          | 89   |       | 0.00       | 13,100      |
| WDC  | Wood Decking   | L   | 717   | 20.00      | 2005   |          | 72   |       | 0.00       | 9,400       |
| FOPC   | Open Prch-roo  | B   | 84    | 55.00      | 2007   |          | 89   |       | 0.00       | 3,700       |
| GAR  | Attached Gara  | B   | 576   | 40.00      | 2007   |          | 89   |       | 0.00       | 18,200      |
| BMT  | Basement-Unfi  | B   | 2,142 | 26.01      | 2007   |          | 89   |       | 0.00       | 42,100      |

| BUILDING SUB-AREA SUMMARY SECTION |                        |             |            |          |           |                |
|-----------------------------------|------------------------|-------------|------------|----------|-----------|----------------|
| Code                              | Description            | Living Area | Floor Area | Eff Area | Unit Cost | Undeprec Value |
| BAS                               | First Floor            | 2,162       | 2,162      | 2,162    | 295.19    | 638,190        |
| BMT                               | Basement Area          | 0           | 2,142      | 0        | 0.00      | 0              |
| FPC                               | Open Porch Conc. Floor | 0           | 84         | 0        | 0.00      | 0              |
| GAR                               | Attached Garage        | 0           | 576        | 0        | 0.00      | 0              |
| WDK                               | Wood Deck              | 0           | 717        | 0        | 0.00      | 0              |
| Ttl Gross Liv / Lease Area        |                        | 2,162       | 5,681      | 2,162    |           | 638,190        |

