

CURRENT OWNER		TOPO	UTILITIES	STRT / ROAD	LOCATION	CURRENT ASSESSMENT			
DENNIS, PATRICK & SARAH ELIZABE 16 TARAMAC ROAD CENTERVILLE MA 02632		1 Level	6 Septic	1 Paved		Description	Code	Assessed	Assessed
			4 Gas			RESIDNTL	1010	296,700	296,700
			2 Public Water			RES LAND	1010	165,300	165,300
SUPPLEMENTAL DATA						Total 462,000 462,000			
Alt Prcl ID Split Zonin BID Parcel ResExpt Q YES: #DL 1 LOT 2 #DL 2 GIS ID F_964241_2701963				Plan Ref. 223/139 Land Ct# #SR Life Estate PP STATU Assoc Pid#					

801
 FY2024
 BARNSTABLE, MA

VISION

RECORD OF OWNERSHIP		BK-VOL/PAGE	SALE DATE	Q/U	V/I	SALE PRIC	VC	PREVIOUS ASSESSMENTS (HISTORY)					
DENNIS, PATRICK & SARAH ELIZABETH		33971 318	04-02-2021	U	I	10	1F	Year	Code	Assessed	Year	Code	Assessed
DENNIS, PATRICK S		18774 0261	06-29-2004	Q	I	282,000	00	2023	1010	255,100	2022	1010	222,800
CAPAK, DOUGLAS A & ROBERTS, DAWN		6147 0160	02-15-1988	Q	I	115,000	U		1010	150,300		1010	111,300
SMITH, HEATHER L & ALLEN, HARRY & J		4652 0293	08-15-1985	Q	I	80,000	U					1010	5,200
HILLER, ROBERT E & SCHULTZ, JEANN		2713 0171	05-26-1978	U		0		Total		405,400	Total		334,100
								Total			Total		294,100

EXEMPTIONS				OTHER ASSESSMENTS			
Year	Code	Description	Amount	Code	Description	Number	Amount
2023	5C	RESIDENTIAL EXEMPTION	0.00				
Total			0.00				

This signature acknowledges a visit by a Data Collector or Assessor

ASSESSING NEIGHBORHOOD			
Nbhd	Nbhd Name	B	Tracing
0105			CENVIL

APPRAISED VALUE SUMMARY	
Appraised Bldg. Value (Card)	261,500
Appraised Xf (B) Value (Bldg)	30,000
Appraised Ob (B) Value (Bldg)	5,200
Appraised Land Value (Bldg)	165,300
Special Land Value	0
Total Appraised Parcel Value	462,000
Valuation Method	C
Total Appraised Parcel Value	462,000

NOTES							

BUILDING PERMIT RECORD								VISIT / CHANGE HISTORY							
Permit Id	Issue Date	Type	Description	Amount	Insp Date	% Comp	Date Comp	Comments	Date	Id	Type	Is	Cd	Purpost/Result	
EXPR-22-1	10-13-2022	835	Sid/Wind/Roof/	3,375		100		Insulation and Air Selaing.	09-20-2022	JO			16	In Office Review	
52538	04-04-2001	AD	Addition	31,950	12-20-2001	100	01-01-2002		04-29-2020	LS				FR	Field Review
52526	04-03-2001	NS	New Siding	1,100	12-20-2001	100	01-01-2002		01-16-2018	KM	02			03	Cycl Insp Comp
									07-05-2007	PT	02			14	Cyclical Inspection

LAND LINE VALUATION SECTION																		
B	Use Code	Description	Zone	LA	Land Units	Unit Price	Size Adj	AC Disc	Site Index	Cond.	Nbhd.	Nbhd. Adj	Notes	Location Adjustmen	Adj Unit P	Land Value		
1	1010	Single Fam M-0	RC	3	0.600	AC	176,344.00	1.56266	1.0000	5	1.00	0105	1.000		1.0000	275,572.7	165,300	
Total Card Land Units					0.60	AC	Parcel Total Land Area					0.60	Total Land Value					165,300

CONSTRUCTION DETAIL			CONSTRUCTION DETAIL (CONTINUED)		
Element	Cd	Description	Element	Cd	Description
Style	01	Ranch			
Model	01	Residential			
Grade:	C	Average			
Stories	1	1 Story			
Exterior Wall 1	14	Wood Shingle			
Exterior Wall 2	11	Clapboard			
RooF Structure	03	Gable/Hip			
RooF Cover	03	Asph/F Gls/Cmp			
Interior Wall 1	05	Drywall			
Interior Wall 2					
Interior Floor 1	12	Hardwood			
Interior Floor 2					
Heat Fuel	03	Gas			
Heat Type	04	Hot Air			
AC Type	03	Central			
Bedrooms	03	3 Bedrooms			
Full Baths	2				
Half Baths	0				
Extra Fixtures					
Total Rooms	5	5 Rooms			
Bath Style					
Kitchen Style					
Occupancy					
Usrflid 105					
Accessory Apt					
Foundation Alt	01	Poured Conc.			
Rms Prts					
Bath Split	20	2 Full-0 Half			
CONDO DATA					
Parcel Id		C	Ownr	0.0	
Adjust Type	Code	Description	Factor%		
Condo Flr					
Condo Unit					
COST / MARKET VALUATION					
Building Value New			335,274		
Year Built			1970		
Effective Year Built			1991		
Depreciation Code			A		
Remodel Rating					
Year Remodeled					
Depreciation %			22		
Functional Obsol			0		
External Obsol			0		
Trend Factor			1		
Condition					
Condition %					
Percent Good			78		
RCNLD			261,500		
Dep % Ovr					
Dep Ovr Comment					
Misc Imp Ovr					
Misc Imp Ovr Comment					
Cost to Cure Ovr					
Cost to Cure Ovr Comment					

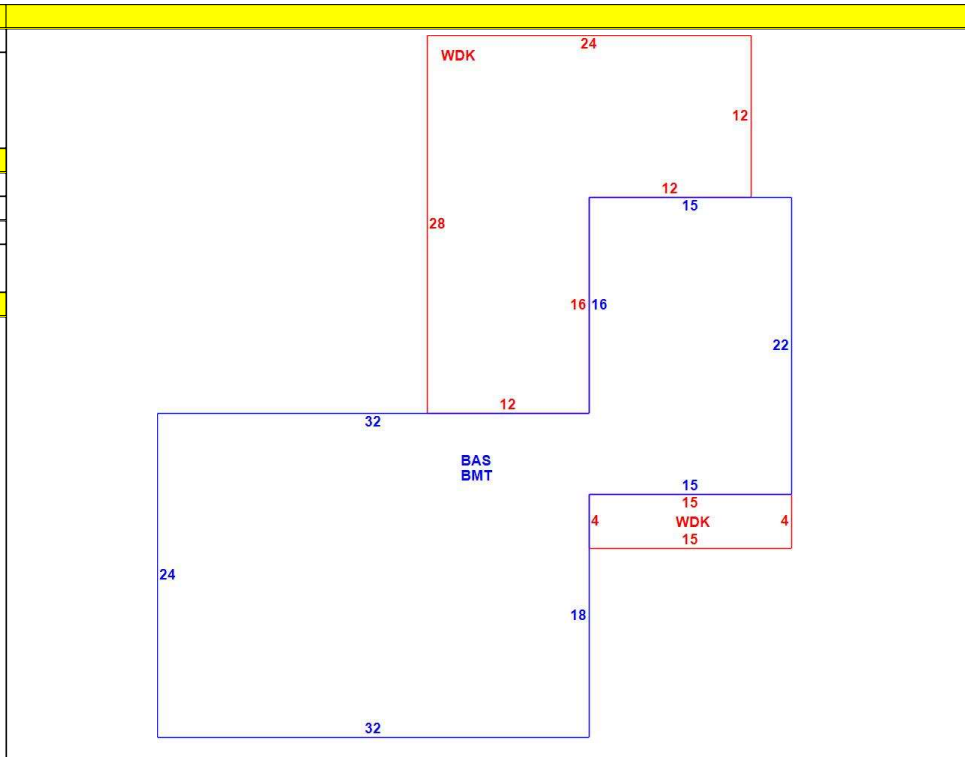

OB - OUTBUILDING & YARD ITEMS(L) / XF - BUILDING EXTRA FEATURES(B)										
Code	Description	L/B	Units	Unit Price	Yr Blt	Cond. Cd	% Gd	Grade	Grade Adj.	Appr. Value
FPL1	Fireplace 1 sto	B	1	5000.00	1993		78		0.00	3,900
BRR	Bsmt Rec Rm-	B	330	8.05	1993		78		0.00	2,100
WDC	Wood Decking	L	540	20.00	1995		52		0.00	5,200
BMT	Basement-Unfi	B	1,098	26.01	1993		78		0.00	22,000
FPLG	Gas Fireplace-	B	1	2500.00	1993		78		0.00	2,000

BUILDING SUB-AREA SUMMARY SECTION						
Code	Description	Living Area	Floor Area	Eff Area	Unit Cost	Undeprec Value
BAS	First Floor	1,098	1,098	1,098	305.35	335,274
BMT	Basement Area	0	1,098	0	0.00	0
WDC	Wood Deck	0	540	0	0.00	0
Ttl Gross Liv / Lease Area		1,098	2,736	1,098		335,274

