

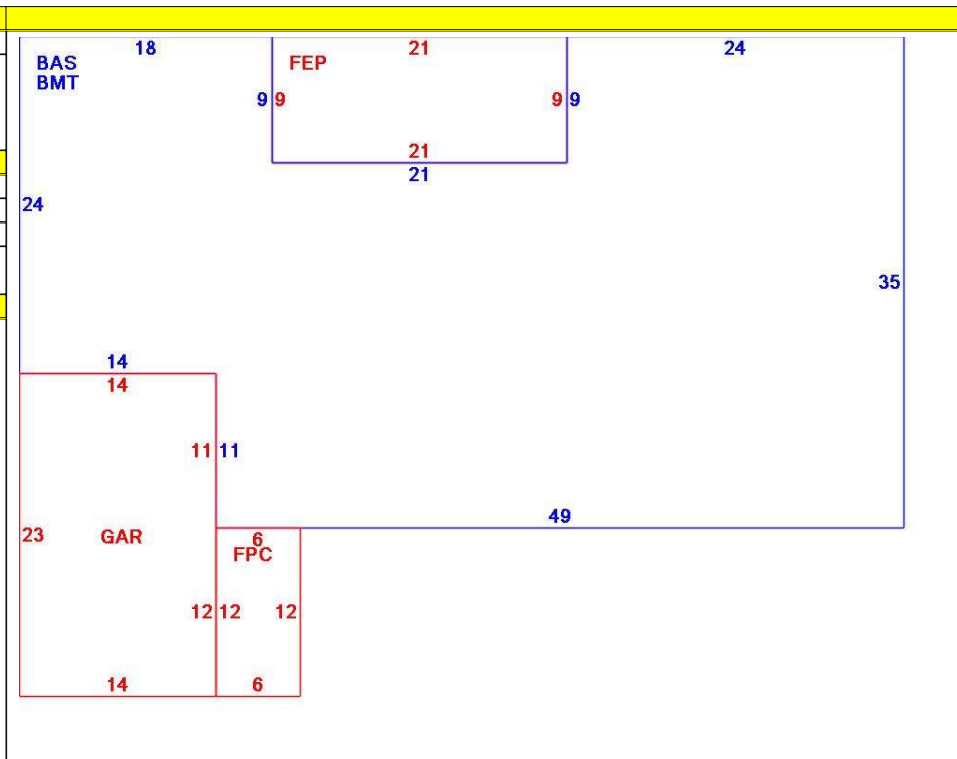

CONSTRUCTION DETAIL			CONSTRUCTION DETAIL (CONTINUED)		
Element	Cd	Description	Element	Cd	Description
Style	01	Ranch			
Model	01	Residential			
Grade:	C	Average			
Stories	1	1 Story			
Exterior Wall 1	14	Wood Shingle			
Exterior Wall 2	11	Clapboard			
RooF Structure	03	Gable/Hip			
RooF Cover	03	Asph/F Gls/Cmp			
Interior Wall 1	05	Drywall			
Interior Wall 2					
Interior Floor 1	14	Carpet			
Interior Floor 2	12	Hardwood			
Heat Fuel	03	Gas			
Heat Type	04	Hot Air			
AC Type	01	None			
Bedrooms	04	4 Bedrooms			
Full Baths	2				
Half Baths	0				
Extra Fixtures					
Total Rooms	8	8 Rooms			
Bath Style					
Kitchen Style					
Occupancy					
Sewer Occupan					
Accessory Apt					
Foundation Alt	01	Poured Conc.			
Rms Prts					
Bath Split	20	2 Full-0 Half			
			<b>CONDO DATA</b>		
Parcel Id			C		Ownr 0.0
Adjust Type		Code	Description	Factor%	
Condo Flr					
Condo Unit					
			<b>COST / MARKET VALUATION</b>		
Building Value New				496,893	
Year Built				1981	
Effective Year Built				2000	
Depreciation Code				A	
Remodel Rating					
Year Remodeled					
Depreciation %				19	
Functional Obsol				0	
External Obsol				0	
Trend Factor				1	
Condition					
Condition %					
Percent Good				81	
RCNLD				402,500	
Dep % Ovr					
Dep Ovr Comment					
Misc Imp Ovr					
Misc Imp Ovr Comment					
Cost to Cure Ovr					
Cost to Cure Ovr Comment					



OB - OUTBUILDING & YARD ITEMS(L) / XF - BUILDING EXTRA FEATURES(B)										
Code	Description	L/B	Units	Unit Price	Yr Blt	Cond. Cd	% Gd	Grade	Grade Adj.	Appr. Value
FPL1	Fireplace 1 sto	B	1	5000.00	1998		81		0.00	4,100
FOPC	Open Prch-roo	B	72	55.00	1998		81		0.00	3,000
FEP	Enclosed porc	B	189	70.00	1998		81		0.00	9,800
GAR	Attached Gara	B	322	40.00	1998		81		0.00	11,300
BMT	Basement-Unfi	B	1,862	26.01	1998		81		0.00	34,100

BUILDING SUB-AREA SUMMARY SECTION						
Code	Description	Living Area	Floor Area	Eff Area	Unit Cost	Undeprec Value
BAS	First Floor	1,862	1,862	1,862	266.86	496,893
BMT	Basement Area	0	1,862	0	0.00	0
FEP	Enclosed Porch	0	189	0	0.00	0
FPC	Open Porch Conc. Floor	0	72	0	0.00	0
GAR	Attached Garage	0	322	0	0.00	0
Ttl Gross Liv / Lease Area		1,862	4,307	1,862		496,893

