

CONSTRUCTION DETAIL			CONSTRUCTION DETAIL (CONTINUED)		
Element	Cd	Description	Element	Cd	Description
Style	55	Condominium			
Model	05	Res Condo			
Grade	B	Custom			
Stories	1	1 Story			
Occupancy					
Interior Wall 1	05	Drywall			
Interior Wall 2					
Interior Floor 1	12	Hardwood			
Interior Floor 2	14	Carpet			
Heat Fuel	03	Gas			
Heat Type	04	Hot Air			
AC Type	03	Central			
Bedrooms	02	2 Bedrooms			
Full Baths	2	2 Full			
Half Baths	0				
Extra Fixtures					
Total Rooms	4				
Bath Style	04	Typical for Gr			
Kitchen Style	04	Typical for Gr			
Master Deed L	1405				
Bath Split	20	2 Full-0 Half			
Foundation	02	Conc. Block			
AC Type Alt					
Sewer Occupan					
CONDO DATA					
Parcel Id	106657	C 108	Ownr	1.8	
	LEWIS BAY CT	B 1	S 1		
Adjust Type	Code	Description	Factor%		
Condo Flr			100		
Condo Unit	VWS	VWS	155		
COST / MARKET VALUATION					
Building Value New		822,256			
Year Built		1999			
Effective Year Built		2018			
Depreciation Code		G			
Remodel Rating					
Year Remodeled					
Depreciation %		5			
Functional Obsol					
External Obsol					
Trend Factor		1			
Condition					
Condition %					
Percent Good		95			
Cns Sect Rcnd		781,100			
Dep % Ovr					
Dep Ovr Comment					
Misc Imp Ovr					
Misc Imp Ovr Comment					
Cost to Cure Ovr					
Cost to Cure Ovr Comment					

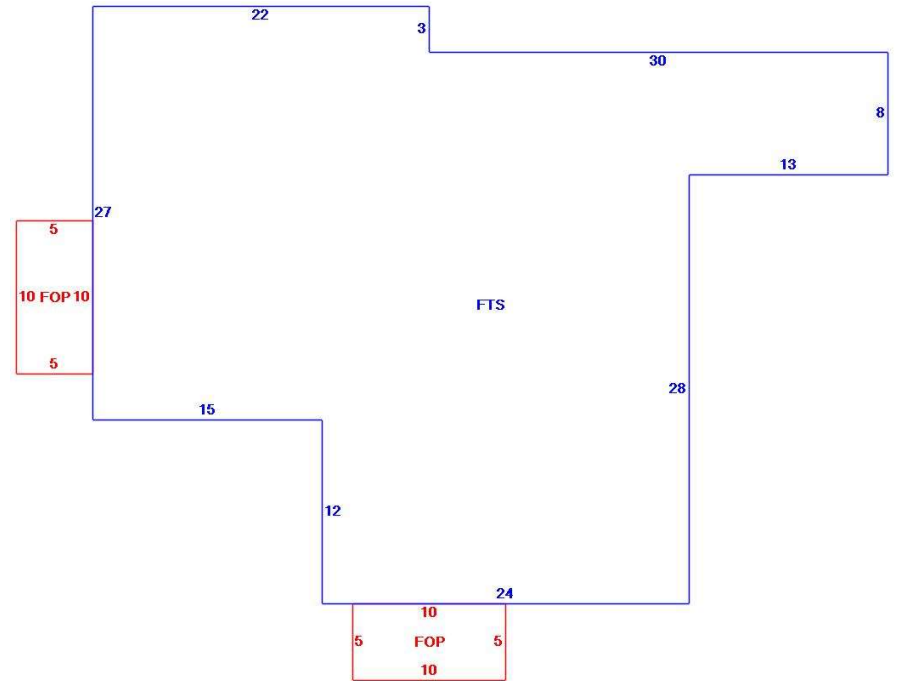

OB - OUTBUILDING & YARD ITEMS(L) / XF - BUILDING EXTRA FEATURES(B)										
Code	Description	L/B	Units	Unit Price	Yr Blt	Cond. Cd	% Gd	Grade	Grade Adj.	Appr. Value
FPLG	Gas Fireplace-	B	1	2500.00	2016		95		0.00	2,400
FOP	Open Porch-ro	B	100	55.00	2016		95		0.00	5,200

BUILDING SUB-AREA SUMMARY SECTION						
Code	Description	Living Area	Floor Area	Eff Area	Unit Cost	Undeprec Value
FOP	Open Porch	0	100	0	0.00	0
FTS	Finished Third Story	1,394	1,394	1,394	589.85	822,253
Ttl Gross Liv / Lease Area		1,394	1,494	1,394		822,253

