

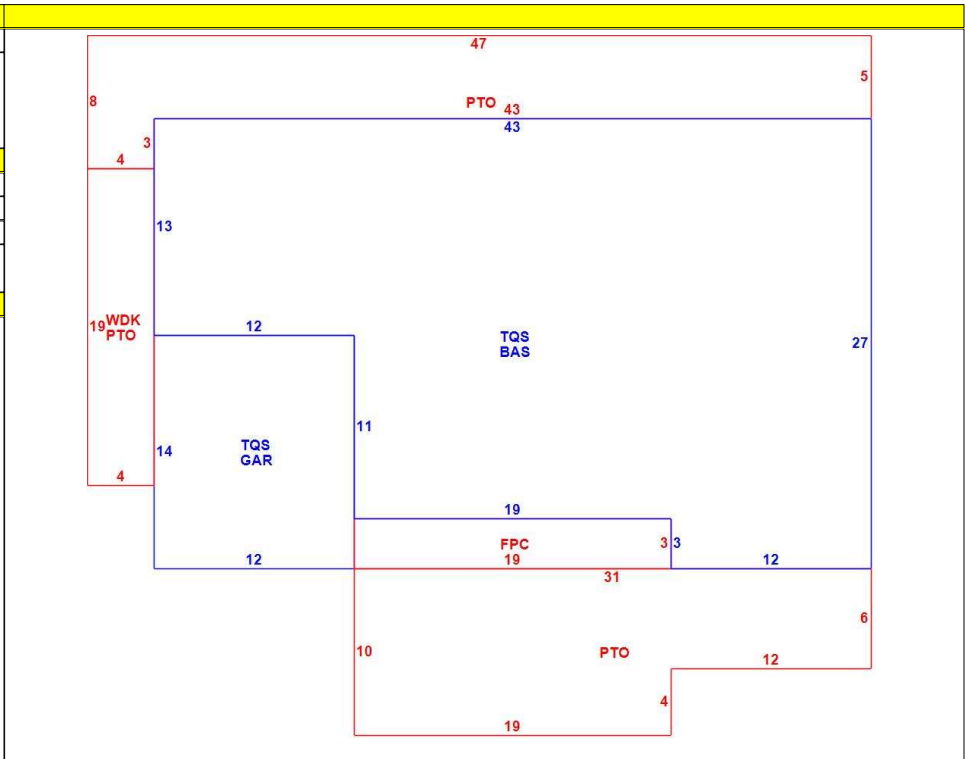

CONSTRUCTION DETAIL			CONSTRUCTION DETAIL (CONTINUED)		
Element	Cd	Description	Element	Cd	Description
Style	04	Cape Cod			
Model	01	Residential			
Grade:	B+	Custom Plus			
Stories	2	2 Stories			
Exterior Wall 1	11	Clapboard			
Exterior Wall 2					
RooF Structure	03	Gable/Hip			
RooF Cover	03	Asph/F Gls/Cmp			
Interior Wall 1	05	Drywall			
Interior Wall 2					
Interior Floor 1	09	Pine/Soft Wood			
Interior Floor 2					
Heat Fuel	03	Gas			
Heat Type	04	Hot Air			
AC Type	03	Central			
Bedrooms	02	2 Bedrooms			
Full Baths	2				
Half Baths	1				
Extra Fixtures					
Total Rooms	7	7 Rooms			
Bath Style					
Kitchen Style					
Occupancy					
Sewer Occupan					
Accessory Apt					
Foundation Alt	04	Brick Walls			
Rms Prts					
Bath Split	21	2 Full-1 Half			

CONDO DATA			
Parcel Id		C	Ownr 0.0
		B	S
Adjust Type	Code	Description	Factor%
Condo Flr			
Condo Unit			

COST / MARKET VALUATION	
Building Value New	698,203
Year Built	1915
Effective Year Built	1994
Depreciation Code	VG
Remodel Rating	
Year Remodeled	
Depreciation %	23
Functional Obsol	0
External Obsol	0
Trend Factor	1
Condition	
Condition %	
Percent Good	77
RCNLD	537,600
Dep % Ovr	
Dep Ovr Comment	
Misc Imp Ovr	
Misc Imp Ovr Comment	
Cost to Cure Ovr	
Cost to Cure Ovr Comment	



**OB - OUTBUILDING & YARD ITEMS(L) / XF - BUILDING EXTRA FEATURES(B)**

Code	Description	L/B	Units	Unit Price	Yr Blt	Cond. Cd	% Gd	Grade	Grade Adj.	Appr. Value
GAR	Attached Gara	B	168	40.00	1989		77		0.00	6,900
FOPC	Open Prch-roo	B	57	55.00	1989		77		0.00	2,400
PATF	Flagstone Pav	L	585	30.00	2023		99		0.00	16,600
WDC	Wood Decking	L	76	20.00	2023		98		0.00	3,300

**BUILDING SUB-AREA SUMMARY SECTION**

Code	Description	Living Area	Floor Area	Eff Area	Unit Cost	Undeprec Value
BAS	First Floor	936	936	936	422.13	395,114
FPC	Open Porch Conc. Floor	0	57	0	0.00	0
GAR	Attached Garage	0	168	0	0.00	0
PTO	Patio	0	585	0	0.00	0
TQS	Three Quarter Story	718	1,104	718	274.54	303,089
WDK	Wood Deck	0	76	0	0.00	0
Ttl Gross Liv / Lease Area		1,654	2,926	1,654		698,203

