

| CURRENT OWNER | | | | TOPO | UTILITIES | STRT / ROAD | LOCATION | CURRENT ASSESSMENT | | | | | | |
|-------------------------|--|--|--|------|-----------|------------------|----------|--------------------|------|----------|----------|---------------------------------|---------|---------|
| MILLER, JOHN D & JANE | | | | | | | | Description | Code | Assessed | Assessed | 801 FY2025 BARNSTABLE, MA | | |
| 81 RALYN ROAD | | | | | | | | RESIDENTL | 1010 | 499,400 | 499,400 | | | |
| COTUIT MA 02635 | | | | | | | | RES LAND | 1010 | 220,000 | 220,000 | | | |
| SUPPLEMENTAL DATA | | | | | | | | | | | | VISION | | |
| Alt Prcl ID | | | | | | Plan Ref. 229/53 | | Total | | | | | 719,400 | 719,400 |
| Split Zonin | | | | | | Land Ct# | | | | | | | | |
| BID Parcel | | | | | | #SR | | | | | | | | |
| ResExpt Q YES: | | | | | | Life Estate | | | | | | | | |
| #DL 1 LOT 24 | | | | | | PP STATU | | | | | | | | |
| #DL 2 | | | | | | Assoc Pid# | | | | | | | | |
| GIS ID F_944311_2691180 | | | | | | | | | | | | | | |

| RECORD OF OWNERSHIP | | | | BK-VOL/PAGE | SALE DATE | Q/U | V/I | SALE PRIC | VC | PREVIOUS ASSESSMENTS (HISTORY) | | | | | | |
|------------------------------|--|--|--|-------------|-----------|------------|-----|-----------|---------|--------------------------------|-------|---------|----------|---------|-------|----------|
| MILLER, JOHN D & JANE | | | | 34332 | 129 | 07-27-2021 | Q | I | 655,000 | 00 | Year | Code | Assessed | Year | Code | Assessed |
| HELEN M MARKS REV TRUST | | | | 34332 | 124 | 03-20-2021 | U | I | 0 | 1F | 2025 | 1010 | 499,400 | 2024 | 1010 | 446,600 |
| MARKS, HELEN M | | | | 32672 | 0073 | 02-05-2020 | U | I | 10 | 1F | | 1010 | 220,000 | | 1010 | 220,000 |
| MARKS, HELEN M | | | | 26292 | 0025 | 04-30-2012 | Q | I | 365,000 | 00 | | | | | | |
| WELLS, DAVID A & CATHERINE S | | | | 24143 | 0086 | 11-05-2009 | U | I | 1 | 1F | | | | | | |
| | | | | | | | | | | | Total | 719,400 | Total | 666,600 | Total | 603,900 |

| EXEMPTIONS | | | | OTHER ASSESSMENTS | | | | This signature acknowledges a visit by a Data Collector or Assessor | | | | | | | | | | |
|------------|------|-----------------------|--------|-------------------|-------------|--------|--------|---|--|--|--|--|--|--|--|--|--|--|
| Year | Code | Description | Amount | Code | Description | Number | Amount | Comm Int | | | | | | | | | | |
| 2023 | 5C | RESIDENTIAL EXEMPTION | 0.00 | | | | | | | | | | | | | | | |
| Total | | | 0.00 | | | | | | | | | | | | | | | |

| ASSESSING NEIGHBORHOOD | | | | APPRAISED VALUE SUMMARY | | | | | | | | | | | | | |
|------------------------|-----------|--|---|-------------------------|--|-------|--|--|--|--|--|--|--|--|--|--|--|
| Nbhd | Nbhd Name | | B | Tracing | | Batch | | | | | | | | | | | |
| 0107 | | | | COTUIT | | | | | | | | | | | | | |

| NOTES | | | | | | | | | | | | APPRAISED VALUE SUMMARY | | | | | |
|-------|--|--|--|--|--|--|--|--|--|--|--|-------------------------------|--|--|--|--|---------|
| | | | | | | | | | | | | Appraised Bldg. Value (Card) | | | | | 422,000 |
| | | | | | | | | | | | | Appraised Xf (B) Value (Bldg) | | | | | 61,800 |
| | | | | | | | | | | | | Appraised Ob (B) Value (Bldg) | | | | | 15,600 |
| | | | | | | | | | | | | Appraised Land Value (Bldg) | | | | | 220,000 |
| | | | | | | | | | | | | Special Land Value | | | | | 0 |
| | | | | | | | | | | | | Total Appraised Parcel Value | | | | | 719,400 |
| | | | | | | | | | | | | Valuation Method | | | | | C |
| | | | | | | | | | | | | Total Appraised Parcel Value | | | | | 719,400 |

| BUILDING PERMIT RECORD | | | | | | | | | | VISIT / CHANGE HISTORY | | | | | |
|------------------------|------------|------|----------------|--------|------------|--------|------------|---------------------------------|--|------------------------|----|------|----|----|-----------------------|
| Permit Id | Issue Date | Type | Description | Amount | Insp Date | % Comp | Date Comp | Comments | | Date | Id | Type | Is | Cd | Purpost/Result |
| EXPR-21-1 | 12-10-2021 | 835 | Sid/Wind/Roof/ | 1,372 | 06-30-2022 | 100 | 06-30-2022 | home air sealing, basement sill | | 01-11-2024 | MM | 01 | 1 | 03 | Cycl Insp Comp |
| BLDR-21-10 | 08-23-2021 | 804 | Addn Alt-Res | 45,000 | 04-22-2022 | 100 | 06-30-2022 | Combining living room and be | | 09-20-2022 | JO | | | 16 | In Office Review |
| 201504079 | 07-16-2015 | IN | Insulation | 2,700 | 06-30-2016 | 100 | 06-30-2016 | WEATHERIZATION | | 04-22-2022 | CK | 01 | | 02 | Bldg Permit Completed |
| 201300362 | 01-15-2013 | RE | Remodel | 20,000 | 10-03-2013 | 100 | 06-30-2014 | REMOD BTH | | 04-13-2022 | BM | 03 | | 16 | In Office Review |
| 64571 | 10-16-2002 | AD | Addition | 25,000 | 02-28-2003 | 100 | 01-01-2003 | 3 SEASON RM | | 05-27-2020 | DM | | | FR | Field Review |
| 41885 | 10-21-1999 | NR | New Roof | 4,700 | 01-01-2000 | 100 | 01-01-2000 | REROOF STRIPPING OLD | | 12-11-2013 | MW | 02 | | 02 | Bldg Permit Completed |
| 15311 | 05-21-1996 | SH | Shed | 1,200 | 06-30-1996 | 100 | 06-30-1996 | SHED 8X10 | | 08-12-2013 | RB | 03 | | 03 | Cycl Insp Comp |

| LAND LINE VALUATION SECTION | | | | | | | | | | | | | | | | | |
|-----------------------------|----------|----------------|------|----|------------|------------|------------------------|---------|------------|-------|-------|-----------|------------------|--|--------------------|------------|------------|
| B | Use Code | Description | Zone | LA | Land Units | Unit Price | Size Adj | AC Disc | Site Index | Cond. | Nbhd. | Nbhd. Adj | Notes | | Location Adjustmen | Adj Unit P | Land Value |
| 1 | 1010 | Single Fam M-0 | RF | 2 | 0.500 | AC | 176,344.00 | 1.78240 | 1.0000 | 5 | 1.00 | 0107 | 1.400 | | 1.0000 | 440,048.8 | 220,000 |
| Total Card Land Units | | | | | 0.50 | AC | Parcel Total Land Area | | | | | 0.50 | Total Land Value | | | | 220,000 |

| CONSTRUCTION DETAIL | | | CONSTRUCTION DETAIL (CONTINUED) | | |
|---------------------|------|----------------|---------------------------------|------|-------------|
| Element | Cd | Description | Element | Cd | Description |
| Style | 04 | Cape Cod | | | |
| Model | 01 | Residential | | | |
| Grade: | C | Average | | | |
| Stories | 1.75 | 1 3/4 Stories | | | |
| Exterior Wall 1 | 14 | Wood Shingle | | | |
| Exterior Wall 2 | 11 | Clapboard | | | |
| RooF Structure | 03 | Gable/Hip | | | |
| RooF Cover | 03 | Asph/F Gls/Cmp | | | |
| Interior Wall 1 | 05 | Drywall | | | |
| Interior Wall 2 | | | | | |
| Interior Floor 1 | 12 | Hardwood | | | |
| Interior Floor 2 | 14 | Carpet | | | |
| Heat Fuel | 03 | Gas | | | |
| Heat Type | 05 | Hot Water | | | |
| AC Type | 03 | Central | | | |
| Bedrooms | 03 | 3 Bedrooms | | | |
| Full Baths | 3 | | | | |
| Half Baths | 0 | | | | |
| Extra Fixtures | | | | | |
| Total Rooms | 5 | 5 Rooms | | | |
| Bath Style | | | | | |
| Kitchen Style | | | | | |
| Occupancy | | | | | |
| Sewer Occupan | | | | | |
| Accessory Apt | | | | | |
| Foundation Alt | 01 | Poured Conc. | | | |
| Rms Prts | | | | | |
| Bath Split | 30 | 3 Full-0 Half | | | |
| | | | CONDO DATA | | |
| | | | Parcel Id | C | Owne 0.0 |
| | | | | B | S |
| | | | Adjust Type | Code | Description |
| | | | Condo Flr | | Factor% |
| | | | Condo Unit | | |
| | | | COST / MARKET VALUATION | | |
| | | | Building Value New | | 502,338 |
| | | | Year Built | | 1979 |
| | | | Effective Year Built | | 2004 |
| | | | Depreciation Code | | G |
| | | | Remodel Rating | | |
| | | | Year Remodeled | | |
| | | | Depreciation % | | 16 |
| | | | Functional Obsol | | 0 |
| | | | External Obsol | | 0 |
| | | | Trend Factor | | 1 |
| | | | Condition | | |
| | | | Condition % | | |
| | | | Percent Good | | 84 |
| | | | RCNLD | | 422,000 |
| | | | Dep % Ovr | | |
| | | | Dep Ovr Comment | | |
| | | | Misc Imp Ovr | | |
| | | | Misc Imp Ovr Comment | | |
| | | | Cost to Cure Ovr | | |
| | | | Cost to Cure Ovr Comment | | |

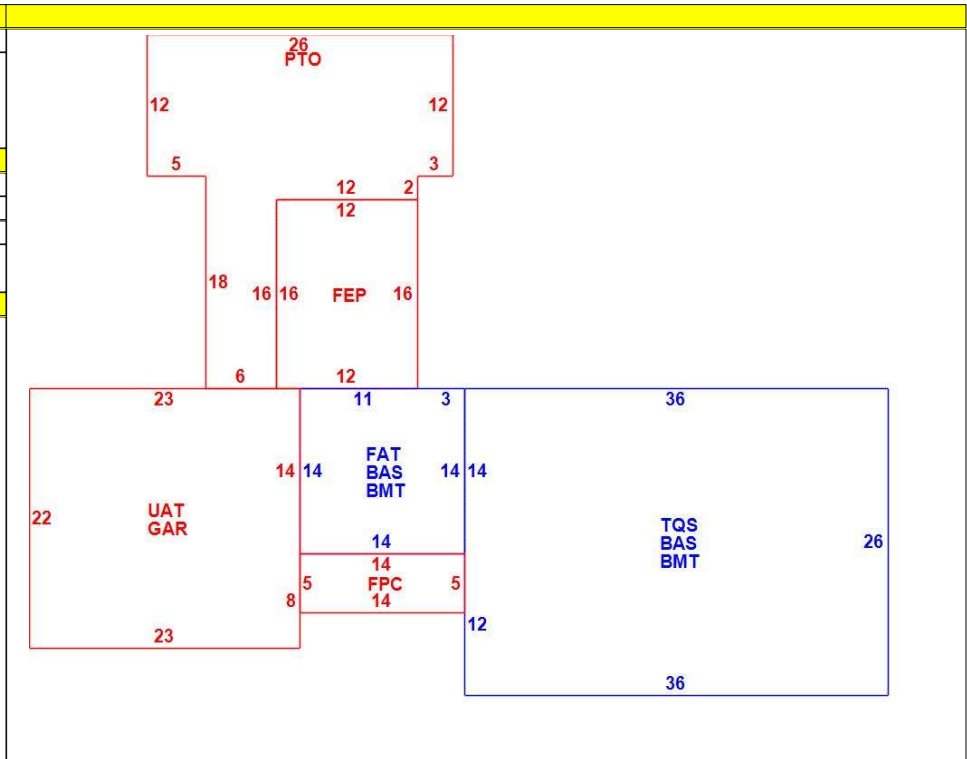

| OB - OUTBUILDING & YARD ITEMS(L) / XF - BUILDING EXTRA FEATURES(B) | | | | | | | | | | |
|--|-----------------|-----|-------|------------|--------|----------|------|-------|------------|-------------|
| Code | Description | L/B | Units | Unit Price | Yr Blt | Cond. Cd | % Gd | Grade | Grade Adj. | Appr. Value |
| FPL2 | Fireplace 1.5 s | B | 1 | 6000.00 | 1997 | | 84 | | 0.00 | 5,000 |
| BRR | Bsmt Rec Rm- | B | 200 | 8.05 | 1997 | | 84 | | 0.00 | 1,400 |
| PATF | Flagstone Pav | L | 444 | 30.00 | 1998 | | 79 | | 0.00 | 10,300 |
| FOPC | Open Prch-roo | B | 70 | 55.00 | 1997 | | 84 | | 0.00 | 3,100 |
| GAR | Attached Gara | B | 506 | 40.00 | 1997 | | 84 | | 0.00 | 15,700 |
| BMT | Basement-Unfi | B | 1,132 | 26.01 | 1997 | | 84 | | 0.00 | 24,200 |
| FPLG | Gas Fireplace- | B | 1 | 2500.00 | 1997 | | 84 | | 0.00 | 2,100 |
| FEP | Enclosed porc | B | 192 | 70.00 | 1997 | | 84 | | 0.00 | 10,300 |
| GEN | Emergency Ge | L | 1 | 5550.00 | 2022 | | 96 | | 0.00 | 5,300 |

| BUILDING SUB-AREA SUMMARY SECTION | | | | | | |
|-----------------------------------|------------------------|-------------|------------|----------|-----------|----------------|
| Code | Description | Living Area | Floor Area | Eff Area | Unit Cost | Undeprec Value |
| BAS | First Floor | 1,132 | 1,132 | 1,132 | 276.01 | 312,443 |
| BMT | Basement Area | 0 | 1,132 | 0 | 0.00 | 0 |
| FAT | Attic, Finished | 29 | 196 | 29 | 40.84 | 8,004 |
| FEP | Enclosed Porch | 0 | 192 | 0 | 0.00 | 0 |
| FPC | Open Porch Conc. Floor | 0 | 70 | 0 | 0.00 | 0 |
| GAR | Attached Garage | 0 | 506 | 0 | 0.00 | 0 |
| PTO | Patio | 0 | 444 | 0 | 0.00 | 0 |
| TQS | Three Quarter Story | 608 | 936 | 608 | 179.29 | 167,814 |
| UAT | Attic, Unfinished | 0 | 506 | 51 | 27.82 | 14,077 |
| Ttl Gross Liv / Lease Area | | 1,769 | 5,114 | 1,820 | | 502,338 |

