

CURRENT OWNER		TOPO	UTILITIES	STRT / ROAD	LOCATION	CURRENT ASSESSMENT				801 FY2025 BARNSTABLE, MA VISION
OLSEN, KATHRYN B TR KATHRYN B OLSEN 2020 LIVING TR 149 SHEAFFER ROAD		1 Level	2 Public Water	1 Paved		Description	Code	Assessed	Assessed	
			4 Gas			RESIDNTL	1010	485,800	485,800	
CENTERVILLE MA 02632			6 Septic		3	RES LAND	1010	152,200	152,200	
		SUPPLEMENTAL DATA					Total			
Alt Prcl ID		Split Zonin		Plan Ref. 247/84						
BID Parcel				Land Ct#						
ResExpt Q YES:				#SR						
#DL 1 LOT 158				Life Estate						
#DL 2				PP STATU						
GIS ID F_964658_2706549				Assoc Pid#						

RECORD OF OWNERSHIP		BK-VOL/PAGE	SALE DATE	Q/U	V/I	SALE PRIC	VC	PREVIOUS ASSESSMENTS (HISTORY)								
OLSEN, KATHRYN B TR		32671 0230	02-05-2020	U	I	1	1F	Year	Code	Assessed	Year	Code	Assessed			
OLSEN, KATHRYN B		30018 0002	10-19-2016	Q	I	367,000	00	2025	1010	485,800	2024	1010	481,100			
TRAMMELL, GUY W & SUSAN B		25954 0114	12-27-2011	Q	I	294,500	00		1010	152,200		1010	152,200			
SMITH, BRIAN A TR		17646 0320	09-16-2003	U	I	1	1F									
SMITH, BRIAN A & LORI J		8454 0286	02-23-1993	Q	I	98,000	U									
Total								638,000		Total		633,300		Total		555,300

EXEMPTIONS				OTHER ASSESSMENTS				This signature acknowledges a visit by a Data Collector or Assessor								
Year	Code	Description	Amount	Code	Description	Number	Amount	Comm Int								
2018	5C	RESIDENTIAL EXEMPTION	0.00													
Total			0.00													

ASSESSING NEIGHBORHOOD				APPRAISED VALUE SUMMARY				
Nbhd	Nbhd Name	B	Tracing	Batch				
0105				CENVIL				
NOTES				Appraised Bldg. Value (Card)				441,700
				Appraised Xf (B) Value (Bldg)				38,300
				Appraised Ob (B) Value (Bldg)				5,800
				Appraised Land Value (Bldg)				152,200
				Special Land Value				0
				Total Appraised Parcel Value				638,000
				Valuation Method				C
				Total Appraised Parcel Value				638,000

BUILDING PERMIT RECORD									VISIT / CHANGE HISTORY					
Permit Id	Issue Date	Type	Description	Amount	Insp Date	% Comp	Date Comp	Comments	Date	Id	Type	Is	Cd	Purpost/Result
EXPR-23-9	07-20-2023	835	Sid/Wind/Roof/	11,900	06-30-2024	100	06-30-2024	re-shingle roof	09-29-2023	WT	01		03	Cycl Insp Comp
19-1335	05-28-2019	839	Solar Panel-Re	32,804	09-10-2019	0		EXPIRED - Roof mounted sola	04-23-2020	LS			FR	Field Review
24312	07-10-1997	RW	Repair Work	1,700	06-30-1998	100	01-01-1998		09-10-2019	SR	02		02	Bldg Permit Completed
B16535	08-01-1973	DW	Dwelling	0	01-15-1974	100	12-31-1974	CE 1STORY	07-25-2017	GC	03		16	In Office Review
									12-08-2016	AL	03		16	In Office Review
									07-22-2014	AL	22		22	Change of Address
									01-21-2014	DR	22		22	Change of Address

LAND LINE VALUATION SECTION																	
B	Use Code	Description	Zone	LA	Land Units	Unit Price	Size Adj	AC Disc	Site Index	Cond.	Nbhd.	Nbhd. Adj	Notes	Location Adjustmen	Adj Unit P	Land Value	
1	1010	Single Fam M-0	RC	3	0.350	AC	176,344.00	2.46674	1.0000	5	1.00	0105	1.000		1.0000	434,987.7	152,200
Total Card Land Units					0.35	AC	Parcel Total Land Area					0.35	Total Land Value			152,200	

CONSTRUCTION DETAIL			CONSTRUCTION DETAIL (CONTINUED)		
Element	Cd	Description	Element	Cd	Description
Style	01	Ranch			
Model	01	Residential			
Grade:	C+	Average Plus			
Stories	1	1 Story			
Exterior Wall 1	14	Wood Shingle			
Exterior Wall 2					
Roof Structure	03	Gable/Hip			
Roof Cover	03	Asph/F Gls/Cmp			
Interior Wall 1	05	Drywall			
Interior Wall 2					
Interior Floor 1	12	Hardwood			
Interior Floor 2	23	Laminate			
Heat Fuel	03	Gas			
Heat Type	05	Hot Water			
AC Type	03	Central			
Bedrooms	03	3 Bedrooms			
Full Baths	1				
Half Baths	1				
Extra Fixtures					
Total Rooms	6	6 Rooms			
Bath Style					
Kitchen Style					
Occupancy					
Sewer Occupan					
Accessory Apt					
Foundation Alt	01	Poured Conc.			
Rms Prts					
Bath Split	11	1 Full-1 Half			

CONDO DATA				
Parcel Id		C	Owne	0.0
Adjust Type	Code	Description	Factor%	
Condo Flr				
Condo Unit				

COST / MARKET VALUATION	
Building Value New	566,220
Year Built	1973
Effective Year Built	1996
Depreciation Code	A
Remodel Rating	
Year Remodeled	
Depreciation %	22
Functional Obsol	0
External Obsol	0
Trend Factor	1
Condition	
Condition %	
Percent Good	78
RCNLD	441,700
Dep % Ovr	
Dep Ovr Comment	
Misc Imp Ovr	
Misc Imp Ovr Comment	
Cost to Cure Ovr	
Cost to Cure Ovr Comment	

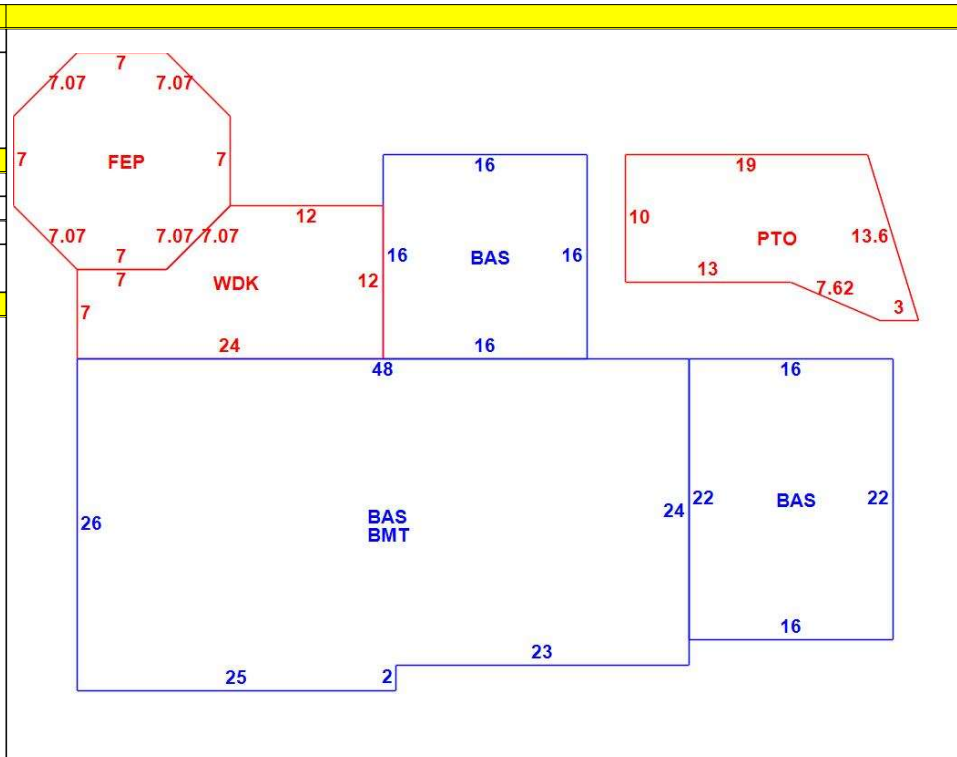

OB - OUTBUILDING & YARD ITEMS(L) / XF - BUILDING EXTRA FEATURES(B)										
Code	Description	L/B	Units	Unit Price	Yr Blt	Cond. Cd	% Gd	Grade	Grade Adj.	Appr. Value
FPL1	Fireplace 1 sto	B	1	5000.00	1994		78		0.00	3,900
WDC	Wood Deck w/	L	240	18.00	1996		54		0.00	2,600
FEP	Enclosed porc	B	239	70.00	1994		78		0.00	11,000
BMT	Basement-Unfi	B	1,202	26.01	1994		78		0.00	23,400
PAT2	Patio-Good	L	224	9.94	1996		77		0.00	1,800
SHD2	Shed w/Elec	L	160	26.00	1986		34		0.00	1,400

BUILDING SUB-AREA SUMMARY SECTION						
Code	Description	Living Area	Floor Area	Eff Area	Unit Cost	Undeprec Value
BAS	First Floor	1,810	1,810	1,810	312.83	566,220
BMT	Basement Area	0	1,202	0	0.00	0
FEP	Enclosed Porch	0	239	0	0.00	0
PTO	Patio	0	224	0	0.00	0
WDK	Wood Deck	0	241	0	0.00	0
Ttl Gross Liv / Lease Area		1,810	3,716	1,810		566,220

