

| CURRENT OWNER | | TOPO | | UTILITIES | | STRT / ROAD | | LOCATION | | CURRENT ASSESSMENT | | | |
|--|--|------------------|-------|------------|--------------|-------------|-------|----------|--|--------------------|------|----------|----------|
| OCONNOR, FRANCIS J 59 FISHER STREET WESTBOROUGH MA 01581 | | 1 | Level | 6 | Septic | 1 | Paved | | | Description | Code | Assessed | Assessed |
| | | | | 4 | Gas | | | | | RESIDENTIAL | 1010 | 447,200 | 447,200 |
| | | | | 2 | Public Water | | | 3 | | RES LAND | 1010 | 152,200 | 152,200 |
| SUPPLEMENTAL DATA | | | | | | | | | | Total | | 599,400 | 599,400 |
| Alt Prcl ID | | Split Zonin | | Plan Ref. | | 306/17-24 | | | | | | | |
| BID Parcel | | ResExpt Q | | NO APP: | | Life Estate | | | | | | | |
| #DL 1 | | LOT 114 | | PP STATU | | | | | | | | | |
| #DL 2 | | | | Assoc Pid# | | | | | | | | | |
| GIS ID | | F_966469_2707815 | | | | | | | | | | | |

801
 FY2025
 BARNSTABLE, MA

VISION

| RECORD OF OWNERSHIP | | BK-VOL/PAGE | | SALE DATE | | Q/U | | V/I | | SALE PRIC | | VC | | PREVIOUS ASSESSMENTS (HISTORY) | | | | | | | |
|---------------------------------|--|-------------|-----|------------|--|-----|---|---------|--|-----------|--|---------|------|--------------------------------|------|---------|----------|-------|------|----------|--|
| OCONNOR, FRANCIS J | | 36305 | 178 | 04-10-2024 | | Q | I | 849,000 | | 00 | | Year | Code | Assessed | Year | Code | Assessed | Year | Code | Assessed | |
| BURKE, ROBERT F | | 35890 | 322 | 07-14-2023 | | Q | I | 565,000 | | 00 | | 2025 | 1010 | 447,200 | 2024 | 1010 | 427,100 | 2023 | 1010 | 381,800 | |
| LEE, ROBERT E TR | | 35089 | 222 | 05-02-2022 | | U | I | 100 | | 1F | | | 1010 | 152,200 | | 1010 | 152,200 | | 1010 | 138,400 | |
| LEE, ROBERT E | | 34843 | 252 | 01-20-2022 | | U | I | 1 | | | | | | | | | | | | | |
| LEE, ROBIN W TR & LEE, ROBERT E | | 34165 | 162 | 06-01-2021 | | U | I | 1 | | 1F | | | | | | | | | | | |
| | | Total | | | | | | | | | | 599,400 | | Total | | 579,300 | | Total | | 520,200 | |

| EXEMPTIONS | | | | OTHER ASSESSMENTS | | | | This signature acknowledges a visit by a Data Collector or Assessor | | | | | | | | | | | |
|------------|------|--------------------------|--------|-------------------|-------------|--------|--------|---|--|--|--|--|--|--|--|--|--|--|--|
| Year | Code | Description | Amount | Code | Description | Number | Amount | | | | | | | | | | | | |
| 2021 | N5C | NO RESIDENTIAL EXEMPTION | 0.00 | | | | | | | | | | | | | | | | |
| | | | Total | | | | | | | | | | | | | | | | |
| | | | 0.00 | | | | | | | | | | | | | | | | |

| ASSESSING NEIGHBORHOOD | | | | APPRAISED VALUE SUMMARY | | | | | |
|------------------------|-----------|--|---|-------------------------|--|--------|--|-------------------------------|---------|
| Nbhd | Nbhd Name | | B | Tracing | | Batch | | Appraised Bldg. Value (Card) | 381,500 |
| 0105 | | | | | | CENVIL | | Appraised Xf (B) Value (Bldg) | 42,800 |
| | | | | | | | | Appraised Ob (B) Value (Bldg) | 22,900 |
| | | | | | | | | Appraised Land Value (Bldg) | 152,200 |
| | | | | | | | | Special Land Value | 0 |
| | | | | | | | | Total Appraised Parcel Value | 599,400 |
| | | | | | | | | Valuation Method | C |
| | | | | | | | | Total Appraised Parcel Value | 599,400 |

| BUILDING PERMIT RECORD | | | | | | | | | VISIT / CHANGE HISTORY | | | | | |
|------------------------|------------|------|----------------|--------|------------|--------|------------|-------------------------|------------------------|----|------|----|----|-----------------------|
| Permit Id | Issue Date | Type | Description | Amount | Insp Date | % Comp | Date Comp | Comments | Date | Id | Type | Is | Cd | Purpost/Result |
| 19-2658 | 08-16-2019 | 835 | Sid/Wind/Roof/ | 5,800 | 06-30-2020 | 100 | 06-30-2020 | reside | 10-03-2023 | WT | 02 | | 03 | Cycl Insp Comp |
| 201206054 | 10-09-2012 | WD | Wood Deck | 5,000 | 08-13-2013 | 100 | 06-30-2013 | DECK 12X13 W STAIRS-REM | 04-23-2020 | LS | | | FR | Field Review |
| 200802684 | 06-20-2008 | SP | Swimming Pool | 26,000 | 08-21-2008 | 100 | 06-30-2009 | 11x27 FG POOL | 08-19-2013 | RB | 03 | | 02 | Bldg Permit Completed |
| 200801348 | 03-13-2008 | NR | New Roof | 6,000 | 06-30-2008 | 100 | 06-30-2008 | REROOF STRIPPING OLD | 12-13-2012 | RB | 03 | | 16 | In Office Review |
| | | | | | | | | | 09-11-2012 | GC | 03 | | 16 | In Office Review |
| | | | | | | | | | 06-25-2009 | NF | 03 | | 16 | In Office Review |
| | | | | | | | | | 06-10-2009 | JG | 03 | | 16 | In Office Review |

| LAND LINE VALUATION SECTION | | | | | | | | | | | | | | | | | | |
|-----------------------------|----------|----------------|------|----|------------|------------|------------------------|---------|------------|-------|-------|-----------|------------------|--------------------|------------|------------|---------|---------|
| B | Use Code | Description | Zone | LA | Land Units | Unit Price | Size Adj | AC Disc | Site Index | Cond. | Nbhd. | Nbhd. Adj | Notes | Location Adjustmen | Adj Unit P | Land Value | | |
| 1 | 1010 | Single Fam M-0 | RC | 3 | 0.350 | AC | 176,344.00 | 2.46674 | 1.0000 | 5 | 1.00 | 0105 | 1.000 | | 1.0000 | 434,987.7 | 152,200 | |
| Total Card Land Units | | | | | 0.35 | AC | Parcel Total Land Area | | | | | 0.35 | Total Land Value | | | | | 152,200 |

| CONSTRUCTION DETAIL | | | CONSTRUCTION DETAIL (CONTINUED) | | |
|--------------------------|------|----------------|---------------------------------|-----|-------------|
| Element | Cd | Description | Element | Cd | Description |
| Style | 04 | Cape Cod | | | |
| Model | 01 | Residential | | | |
| Grade: | C | Average | | | |
| Stories | 1.75 | 1 3/4 Stories | | | |
| Exterior Wall 1 | 14 | Wood Shingle | | | |
| Exterior Wall 2 | 19 | Brick Veneer | | | |
| RooF Structure | 03 | Gable/Hip | | | |
| RooF Cover | 03 | Asph/F Gls/Cmp | | | |
| Interior Wall 1 | 05 | Drywall | | | |
| Interior Wall 2 | | | | | |
| Interior Floor 1 | 12 | Hardwood | | | |
| Interior Floor 2 | 14 | Carpet | | | |
| Heat Fuel | 03 | Gas | | | |
| Heat Type | 05 | Hot Water | | | |
| AC Type | 01 | None | | | |
| Bedrooms | 03 | 3 Bedrooms | | | |
| Full Baths | 2 | | | | |
| Half Baths | 1 | | | | |
| Extra Fixtures | | | | | |
| Total Rooms | 6 | 6 Rooms | | | |
| Bath Style | | | | | |
| Kitchen Style | | | | | |
| Occupancy | | | | | |
| Sewer Occupan | | | | | |
| Accessory Apt | | | | | |
| Foundation Alt | 01 | Poured Conc. | | | |
| Rms Prts | | | | | |
| Bath Split | 21 | 2 Full-1 Half | | | |
| CONDO DATA | | | COST / MARKET VALUATION | | |
| Parcel Id | | C | Owne | 0.0 | |
| Adjust Type | Code | Description | Factor% | | |
| Condo Flr | | | | | |
| Condo Unit | | | | | |
| Building Value New | | 476,822 | | | |
| Year Built | | 1976 | | | |
| Effective Year Built | | 1998 | | | |
| Depreciation Code | | A | | | |
| Remodel Rating | | | | | |
| Year Remodeled | | | | | |
| Depreciation % | | 20 | | | |
| Functional Obsol | | 0 | | | |
| External Obsol | | 0 | | | |
| Trend Factor | | 1 | | | |
| Condition | | | | | |
| Condition % | | | | | |
| Percent Good | | 80 | | | |
| RCNLD | | 381,500 | | | |
| Dep % Ovr | | | | | |
| Dep Ovr Comment | | | | | |
| Misc Imp Ovr | | | | | |
| Misc Imp Ovr Comment | | | | | |
| Cost to Cure Ovr | | | | | |
| Cost to Cure Ovr Comment | | | | | |

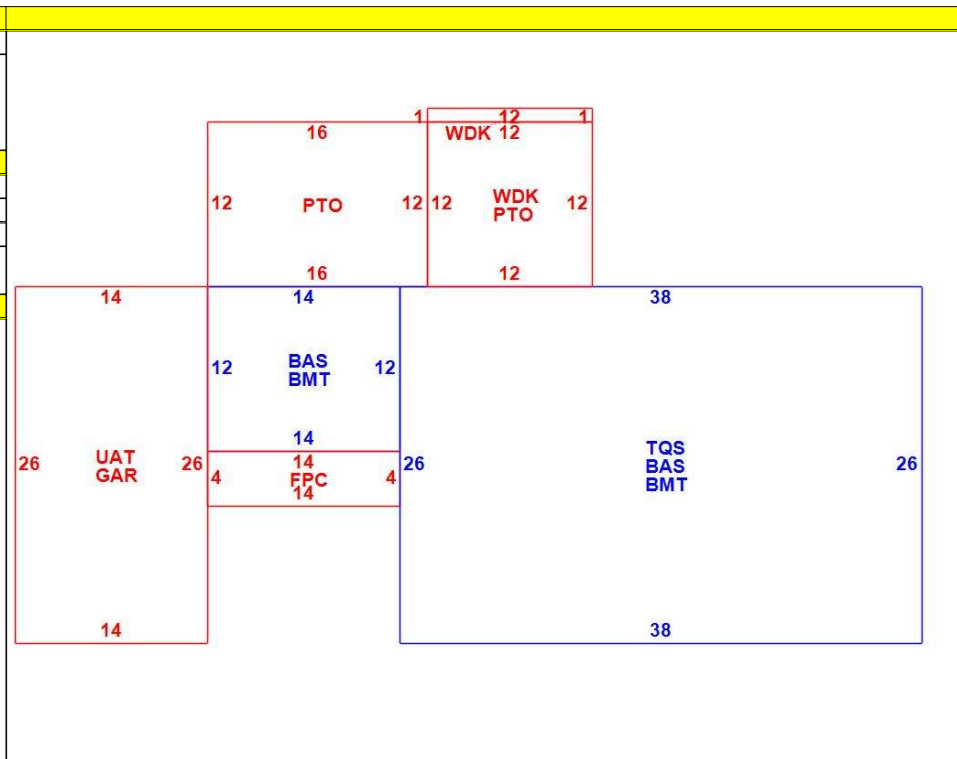

| OB - OUTBUILDING & YARD ITEMS(L) / XF - BUILDING EXTRA FEATURES(B) | | | | | | | | | | |
|--|-----------------|-----|-------|------------|--------|----------|------|-------|------------|-------------|
| Code | Description | L/B | Units | Unit Price | Yr Blt | Cond. Cd | % Gd | Grade | Grade Adj. | Appr. Value |
| FPL2 | Fireplace 1.5 s | B | 1 | 6000.00 | 1996 | | 80 | | 0.00 | 4,800 |
| SPL2 | Pool Vinyl | L | 297 | 55.00 | 2008 | | 68 | 00 | 1.00 | 12,700 |
| PAT1 | Patio- Average | L | 336 | 5.89 | 1997 | | 78 | | 0.00 | 1,500 |
| FOPC | Open Prch-roo | B | 56 | 55.00 | 1996 | | 80 | | 0.00 | 2,500 |
| GAR | Attached Gara | B | 364 | 40.00 | 1996 | | 80 | | 0.00 | 12,100 |
| BMT | Basement-Unfi | B | 1,156 | 26.01 | 1996 | | 80 | | 0.00 | 23,400 |
| WDC | Wood Decking | L | 156 | 20.00 | 2012 | | 86 | | 0.00 | 3,600 |
| PAT1 | Patio- Average | L | 416 | 5.89 | 2008 | | 89 | | 0.00 | 2,100 |
| FNP3 | FENCE VINYL | L | 142 | 27.05 | 2008 | | 68 | C | 1.00 | 2,600 |
| FNG1 | Gate 4'x3'w | L | 2 | 301.53 | 2008 | | 68 | 00 | 1.00 | 400 |

| BUILDING SUB-AREA SUMMARY SECTION | | | | | | |
|-----------------------------------|------------------------|-------------|------------|----------|-----------|----------------|
| Code | Description | Living Area | Floor Area | Eff Area | Unit Cost | Undeprec Value |
| BAS | First Floor | 1,156 | 1,156 | 1,156 | 259.99 | 300,548 |
| BMT | Basement Area | 0 | 1,156 | 0 | 0.00 | 0 |
| FPC | Open Porch Conc. Floor | 0 | 56 | 0 | 0.00 | 0 |
| GAR | Attached Garage | 0 | 364 | 0 | 0.00 | 0 |
| PTO | Patio | 0 | 336 | 0 | 0.00 | 0 |
| TQS | Three Quarter Story | 642 | 988 | 642 | 168.94 | 166,914 |
| UAT | Attic, Unfinished | 0 | 364 | 36 | 25.71 | 9,360 |
| WDK | Wood Deck | 0 | 156 | 0 | 0.00 | 0 |
| Ttl Gross Liv / Lease Area | | 1,798 | 4,576 | 1,834 | | 476,822 |

