

| CURRENT OWNER | | TOPO | UTILITIES | STRT / ROAD | LOCATION | CURRENT ASSESSMENT | | | | 801 FY2025 BARNSTABLE, MA VISION | |
|------------------------------|--|--|----------------|--|--------------|--------------------|------|-----------|-----------|--|-----------|
| 293 LONG BEACH ROAD LLC | | 1 Level | 2 Public Water | 1 Paved | 7 Waterfront | Description | Code | Assessed | Assessed | | |
| | | | 4 Gas | | 1 Excel View | RESIDNTL | 1010 | 1,520,500 | 1,520,500 | | |
| | | | 6 Septic | | 3 | RES LAND | 1010 | 2,857,800 | 2,857,800 | | |
| 1063 HILLSBORO MILE UNIT 207 | | SUPPLEMENTAL DATA | | | | Total | | | | 4,378,300 | 4,378,300 |
| HILLSBORO BE FL 33062 | | Alt Prcl ID Split Zonin BID Parcel ResExpt Q #DL 1 #DL 2 GIS ID F_969859_2694093 | | Plan Ref. Land Ct# #SR Life Estate PP STATU A:Active Assoc Pid# | | | | | | | |

| RECORD OF OWNERSHIP | | BK-VOL/PAGE | SALE DATE | Q/U | V/I | SALE PRIC | VC | PREVIOUS ASSESSMENTS (HISTORY) | | | | | | |
|---------------------------|--|-------------|-----------|------------|-----|-----------|----|--------------------------------|-------|-------|-----------|-------|------|-----------|
| 293 LONG BEACH ROAD LLC | | C216782 | 0 | 07-18-2018 | U | I | 10 | 1F | Year | Code | Assessed | Year | Code | Assessed |
| HASEOTES, JOYCE E TR | | C197056 | 0 | 05-10-2012 | U | I | 1 | 1F | 2025 | 1010 | 1,520,500 | 2024 | 1010 | 1,425,900 |
| HASEOTES, JOYCE E | | #D11243 | 0 | 09-25-2009 | U | I | 0 | 1 | | 1010 | 2,857,800 | 2023 | 1010 | 1,214,000 |
| HASEOTES, BYRON & JOYCE E | | C58363 | 0 | 04-27-1973 | U | | 0 | | Total | | 4,378,300 | Total | | 4,283,700 |
| | | | | | | | | | | Total | | | | 2,895,000 |

| EXEMPTIONS | | | OTHER ASSESSMENTS | | | | This signature acknowledges a visit by a Data Collector or Assessor | | | | | |
|------------|------|-------------|-------------------|------|-------------|--------|---|----------|--|--|--|--|
| Year | Code | Description | Amount | Code | Description | Number | Amount | Comm Int | | | | |
| Total | | 0.00 | | | | | | | | | | |

| ASSESSING NEIGHBORHOOD | | | | APPRAISED VALUE SUMMARY | | | | |
|------------------------|-----------|---|---------|-------------------------|--|--|--|--|
| Nbhd | Nbhd Name | B | Tracing | Batch | | | | |
| 0121 | | | | CENVIL | | | | |

| NOTES | | | | | | | | | | | | | |
|-------|--|--|--|--|--|--|--|--|--|--|--|--|--|
| | | | | | | | | | | | | | |

| BUILDING PERMIT RECORD | | | | | | | | | | VISIT / CHANGE HISTORY | | | | | |
|------------------------|------------|------|----------------|---------|------------|--------|------------|-----------------------------------|--|------------------------|----|------|----|----|------------------|
| Permit Id | Issue Date | Type | Description | Amount | Insp Date | % Comp | Date Comp | Comments | | Date | Id | Type | Is | Cd | Purpost/Result |
| EXPR-21-7 | 05-10-2021 | 835 | Sid/Wind/Roof/ | 3,000 | | 100 | | Remove and replace kitchen | | 06-30-2023 | TR | 03 | | 16 | In Office Review |
| 17-3179 | 09-14-2017 | 835 | Sid/Wind/Roof/ | 2,500 | | 100 | | replace 1 window .32 uvalue | | 09-30-2020 | SR | 02 | | 03 | Cycl Insp Comp |
| 16-2006 | 07-13-2016 | 835 | Sid/Wind/Roof/ | 10,000 | | 100 | | Reroof (partial flat roof only) R | | 05-27-2020 | WD | | | FR | Field Review |
| 200904231 | 09-25-2009 | AD | Addition | 400,000 | 05-28-2010 | 100 | 06-30-2010 | 2BDRM ADDN WEST SIDE | | | | | | | |
| 89550 | 01-09-2006 | NW | New Windows | 13,000 | 05-28-2010 | 100 | 06-30-2010 | | | | | | | | |
| B32879 | 05-01-1989 | AD | Addition | 40,000 | 01-15-1996 | 100 | | CE ADD'N | | | | | | | |

| LAND LINE VALUATION SECTION | | | | | | | | | | | | | | | | | |
|-----------------------------|----------|----------------|------|----|------------|------------|------------------------|---------|------------|-------|-------|-----------|------------------|--------------------|------------|------------|-----------|
| B | Use Code | Description | Zone | LA | Land Units | Unit Price | Size Adj | AC Disc | Site Index | Cond. | Nbhd. | Nbhd. Adj | Notes | Location Adjustmen | Adj Unit P | Land Value | |
| 1 | 1010 | Single Fam M-0 | CBD | 3 | 0.660 | AC | 176,344.00 | 1.44436 | 1.0000 | 5 | 1.00 | 0121 | 17.000 | | 1.0000 | 4,329,968 | 2,857,800 |
| Total Card Land Units | | | | | 0.66 | AC | Parcel Total Land Area | | | | | 0.66 | Total Land Value | | | 2,857,800 | |

| CURRENT OWNER | | TOPO | UTILITIES | STRT / ROAD | LOCATION | CURRENT ASSESSMENT | | | | 801 FY2025 BARNSTABLE, MA VISION | |
|------------------------------|--|--|----------------|--|--------------|--------------------|------|-----------|-----------|--|-----------|
| 293 LONG BEACH ROAD LLC | | 1 Level | 2 Public Water | 1 Paved | 7 Waterfront | Description | Code | Assessed | Assessed | | |
| | | | 4 Gas | | 1 Excel View | RESIDNTL | 1010 | 1,520,500 | 1,520,500 | | |
| | | | 6 Septic | | 3 | RES LAND | 1010 | 2,857,800 | 2,857,800 | | |
| 1063 HILLSBORO MILE UNIT 207 | | SUPPLEMENTAL DATA | | | | Total | | | | 4,378,300 | 4,378,300 |
| HILLSBORO BE FL 33062 | | Alt Prcl ID Split Zonin BID Parcel ResExpt Q #DL 1 #DL 2 GIS ID F_969859_2694093 | | Plan Ref. Land Ct# #SR Life Estate PP STATU A:Active Assoc Pid# | | | | | | | |

| RECORD OF OWNERSHIP | | BK-VOL/PAGE | SALE DATE | Q/U | V/I | SALE PRIC | VC | PREVIOUS ASSESSMENTS (HISTORY) | | | | | | | |
|---------------------------|--|-------------|-----------|------------|-----|-----------|----|--------------------------------|-------|-----------|-----------|-------|------|-----------|--|
| 293 LONG BEACH ROAD LLC | | C216782 | 0 | 07-18-2018 | U | I | 10 | 1F | Year | Code | Assessed | Year | Code | Assessed | |
| HASEOTES, JOYCE E TR | | C197056 | 0 | 05-10-2012 | U | I | 1 | 1F | 2025 | 1010 | 1,520,500 | 2024 | 1010 | 1,425,900 | |
| HASEOTES, JOYCE E | | #D11243 | 0 | 09-25-2009 | U | I | 0 | 1 | | 1010 | 2,857,800 | 2023 | 1010 | 1,214,000 | |
| HASEOTES, BYRON & JOYCE E | | C58363 | 0 | 04-27-1973 | U | | 0 | | Total | | 4,378,300 | Total | | 4,283,700 | |
| | | | | | | | | Total | | 2,895,000 | | | | | |

| EXEMPTIONS | | | OTHER ASSESSMENTS | | | | This signature acknowledges a visit by a Data Collector or Assessor | | | | | |
|------------|------|-------------|-------------------|------|-------------|--------|---|----------|--|--|--|--|
| Year | Code | Description | Amount | Code | Description | Number | Amount | Comm Int | | | | |
| | | | | | | | | | | | | |
| Total | | | 0.00 | | | | | | | | | |

| ASSESSING NEIGHBORHOOD | | | | APPRAISED VALUE SUMMARY | | | | | |
|------------------------|-----------|---|---------|-------------------------|--|--|-------------------------------|-------------------------------|-----------|
| Nbhd | Nbhd Name | B | Tracing | Batch | | | | Appraised Bldg. Value (Card) | 1,438,000 |
| 0121 | | | CENVIL | | | | Appraised Xf (B) Value (Bldg) | 67,900 | |
| NOTES | | | | | | | | Appraised Ob (B) Value (Bldg) | 14,600 |
| | | | | | | | | Appraised Land Value (Bldg) | 2,857,800 |
| | | | | | | | | Special Land Value | 0 |
| | | | | | | | | Total Appraised Parcel Value | 4,378,300 |
| | | | | | | | | Valuation Method | C |
| | | | | | | | | Total Appraised Parcel Value | 4,378,300 |

| BUILDING PERMIT RECORD | | | | | | | | VISIT / CHANGE HISTORY | | | | | | |
|------------------------|------------|------|----------------|---------|------------|--------|------------|-----------------------------------|------------|----|------|----|----|------------------|
| Permit Id | Issue Date | Type | Description | Amount | Insp Date | % Comp | Date Comp | Comments | Date | Id | Type | Is | Cd | Purpost/Result |
| EXPR-21-7 | 05-10-2021 | 835 | Sid/Wind/Roof/ | 3,000 | | 100 | | Remove and replace kitchen | 06-30-2023 | TR | 03 | | 16 | In Office Review |
| 17-3179 | 09-14-2017 | 835 | Sid/Wind/Roof/ | 2,500 | | 100 | | replace 1 window .32 uvalue | 09-30-2020 | SR | 02 | | 03 | Cycl Insp Comp |
| 16-2006 | 07-13-2016 | 835 | Sid/Wind/Roof/ | 10,000 | | 100 | | Reroof (partial flat roof only) R | 05-27-2020 | WD | | | FR | Field Review |
| 200904231 | 09-25-2009 | AD | Addition | 400,000 | 05-28-2010 | 100 | 06-30-2010 | 2BDRM ADDN WEST SIDE | | | | | | |
| 89550 | 01-09-2006 | NW | New Windows | 13,000 | 05-28-2010 | 100 | 06-30-2010 | | | | | | | |
| B32879 | 05-01-1989 | AD | Addition | 40,000 | 01-15-1996 | 100 | | CE ADD'N | | | | | | |

| LAND LINE VALUATION SECTION | | | | | | | | | | | | | | | | | |
|-----------------------------|----------|----------------|------|----|------------|------------|------------------------|---------|------------|-------|-------|-----------|------------------|--------------------|------------|------------|-----------|
| B | Use Code | Description | Zone | LA | Land Units | Unit Price | Size Adj | AC Disc | Site Index | Cond. | Nbhd. | Nbhd. Adj | Notes | Location Adjustmen | Adj Unit P | Land Value | |
| 1 | 1010 | Single Fam M-0 | CBD | 3 | 0.660 | AC | 176,344.00 | 1.44436 | 1.0000 | 5 | 1.00 | 0121 | 17.000 | | 1.0000 | 4,329,968 | 2,857,800 |
| Total Card Land Units | | | | | 0.66 | AC | Parcel Total Land Area | | | | | 0.66 | Total Land Value | | | 2,857,800 | |

| CONSTRUCTION DETAIL | | | CONSTRUCTION DETAIL (CONTINUED) | | |
|---------------------|----|----------------|---------------------------------|------|-------------|
| Element | Cd | Description | Element | Cd | Description |
| Style | 06 | Conventional | | | |
| Model | 01 | Residential | | | |
| Grade: | B | Custom | | | |
| Stories | 2 | 2 Stories | | | |
| Exterior Wall 1 | 12 | Cedar or Redwd | | | |
| Exterior Wall 2 | | | | | |
| CONDO DATA | | | | | |
| Roof Structure | 03 | Gable/Hip | Parcel Id | | C |
| Roof Cover | 10 | Wood Shingle | | | Owne 0.0 |
| Interior Wall 1 | 02 | Wall Brd/Wood | Adjust Type | Code | Description |
| Interior Wall 2 | 05 | Drywall | Condo Flr | | |
| Interior Floor 1 | 09 | Pine/Soft Wood | Condo Unit | | |
| Interior Floor 2 | | | COST / MARKET VALUATION | | |
| Heat Fuel | 03 | Gas | Building Value New | | 1,848,806 |
| Heat Type | 04 | Hot Air | Year Built | | 2009 |
| AC Type | 03 | Central | Effective Year Built | | 2014 |
| Bedrooms | 04 | 4 Bedrooms | Depreciation Code | | A |
| Full Baths | 4 | | Remodel Rating | | |
| Half Baths | 1 | | Year Remodeled | | |
| Extra Fixtures | | | Depreciation % | | 8 |
| Total Rooms | 13 | | Functional Obsol | | 0 |
| Bath Style | | | External Obsol | | 0 |
| Kitchen Style | | | Trend Factor | | 1 |
| Occupancy | | | Condition | | |
| Sewer Occupan | | | Condition % | | 92 |
| Accessory Apt | 00 | Typical | Percent Good | | 92 |
| Foundation Alt | | | RCNLD | | 1,438,000 |
| Rms Prts | | | Dep % Ovr | | |
| Bath Split | 41 | 4 Full-1 Half | Dep Ovr Comment | | |
| | | | Misc Imp Ovr | | |
| | | | Misc Imp Ovr Comment | | |
| | | | Cost to Cure Ovr | | |
| | | | Cost to Cure Ovr Comment | | |

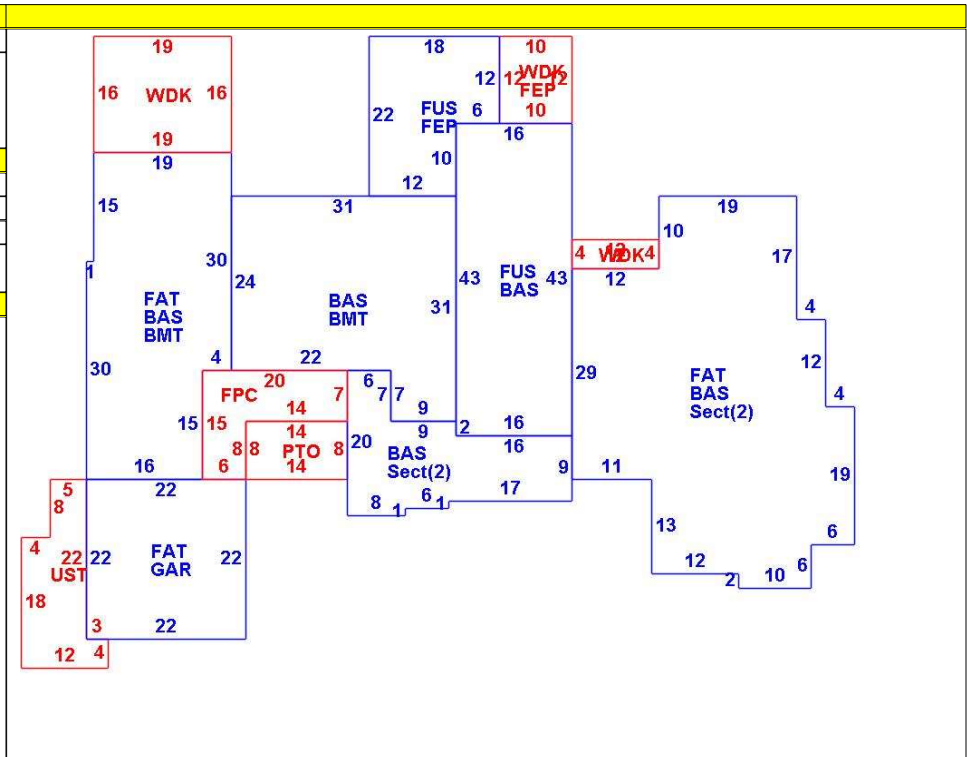

| OB - OUTBUILDING & YARD ITEMS(L) / XF - BUILDING EXTRA FEATURES(B) | | | | | | | | | | |
|--|---------------|-----|-------|------------|--------|----------|------|-------|------------|-------------|
| Code | Description | L/B | Units | Unit Price | Yr Blt | Cond. Cd | % Gd | Grade | Grade Adj. | Appr. Value |
| WDC | Deck composit | L | 48 | 24.00 | 2010 | | 82 | | 0.00 | 2,700 |
| PATF | Flagstone Pav | L | 112 | 30.00 | 2010 | | 91 | | 0.00 | 3,600 |

| BUILDING SUB-AREA SUMMARY SECTION | | | | | | |
|-----------------------------------|-----------------|-------------|------------|----------|-----------|----------------|
| Code | Description | Living Area | Floor Area | Eff Area | Unit Cost | Undeprec Value |
| BAS | First Floor | 1,950 | 1,950 | 1,950 | 322.82 | 629,504 |
| FAT | Attic, Finished | 237 | 1,577 | 237 | 48.52 | 76,509 |
| Ttl Gross Liv / Lease Area | | 2,187 | 3,527 | 2,187 | | 706,013 |

