

CONSTRUCTION DETAIL			CONSTRUCTION DETAIL (CONTINUED)		
Element	Cd	Description	Element	Cd	Description
Style	04	Cape Cod			
Model	01	Residential			
Grade:	C	Average			
Stories	1.75	1 3/4 Stories			
Exterior Wall 1	25	Vinyl Siding			
Exterior Wall 2	14	Wood Shingle			
Roof Structure	03	Gable/Hip			
Roof Cover	03	Asph/F Gls/Cmp			
Interior Wall 1	05	Drywall			
Interior Wall 2					
Interior Floor 1	14	Carpet			
Interior Floor 2	12	Hardwood			
Heat Fuel	03	Gas			
Heat Type	05	Hot Water			
AC Type	01	None			
Bedrooms	03	3 Bedrooms			
Full Baths	2				
Half Baths	0				
Extra Fixtures					
Total Rooms	7	7 Rooms			
Bath Style					
Kitchen Style					
Occupancy					
Sewer Occupan					
Accessory Apt					
Foundation Alt	01	Poured Conc.			
Rms Prts					
Bath Split	20	2 Full-0 Half			
			CONDO DATA		
			Parcel Id	C	Owne 0.0
				B	S
			Adjust Type	Code	Description
			Condo Flr		
			Condo Unit		
			COST / MARKET VALUATION		
			Building Value New		475,162
			Year Built		1974
			Effective Year Built		1997
			Depreciation Code		A
			Remodel Rating		
			Year Remodeled		
			Depreciation %		21
			Functional Obsol		0
			External Obsol		0
			Trend Factor		1
			Condition		
			Condition %		
			Percent Good		79
			RCNLD		375,400
			Dep % Ovr		
			Dep Ovr Comment		
			Misc Imp Ovr		
			Misc Imp Ovr Comment		
			Cost to Cure Ovr		
			Cost to Cure Ovr Comment		

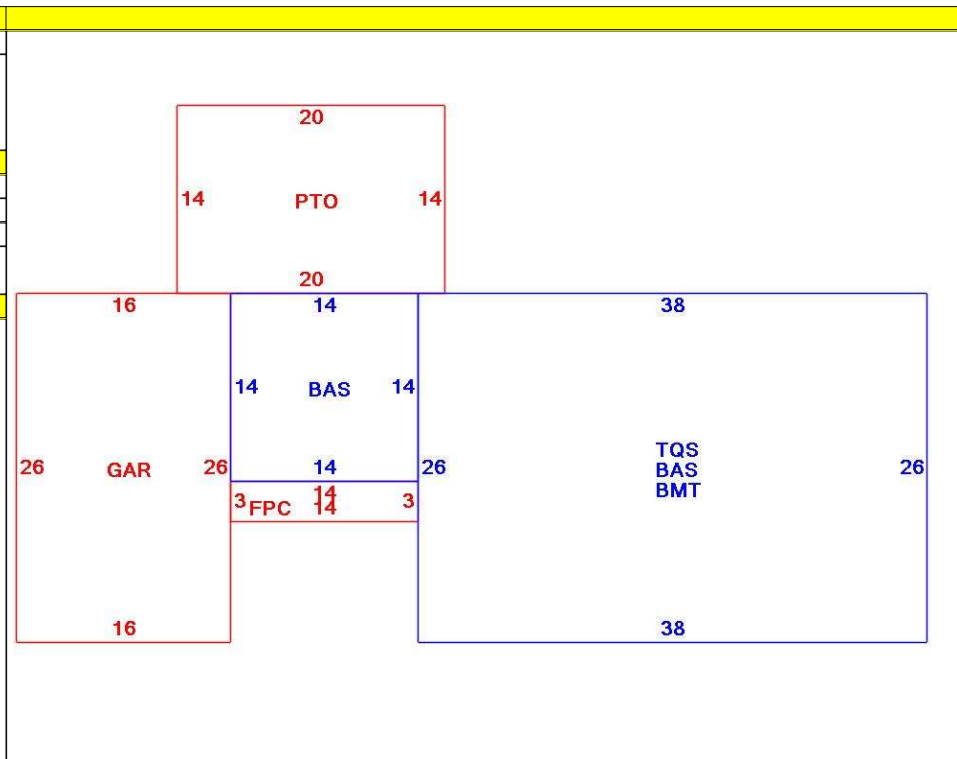

OB - OUTBUILDING & YARD ITEMS(L) / XF - BUILDING EXTRA FEATURES(B)										
Code	Description	L/B	Units	Unit Price	Yr Blt	Cond. Cd	% Gd	Grade	Grade Adj.	Appr. Value
FPL2	Fireplace 1.5 s	B	1	6000.00	1995		79		0.00	4,700
PAT1	Patio- Average	L	280	5.89	1996		77		0.00	1,300
GAR	Attached Gara	B	416	40.00	1995		79		0.00	13,000
BMT	Basement-Unfi	B	988	26.01	1995		79		0.00	20,800
FOPC	Open Prch-roo	B	42	55.00	1995		79		0.00	2,000
GEN	Emergency Ge	L	1	5550.00	2016		94		0.00	5,200

BUILDING SUB-AREA SUMMARY SECTION						
Code	Description	Living Area	Floor Area	Eff Area	Unit Cost	Undeprec Value
BAS	First Floor	1,184	1,184	1,184	260.22	308,100
BMT	Basement Area	0	988	0	0.00	0
FPC	Open Porch Conc. Floor	0	42	0	0.00	0
GAR	Attached Garage	0	416	0	0.00	0
PTO	Patio	0	280	0	0.00	0
TQS	Three Quarter Story	642	988	642	169.09	167,061
Ttl Gross Liv / Lease Area		1,826	3,898	1,826		475,161

