

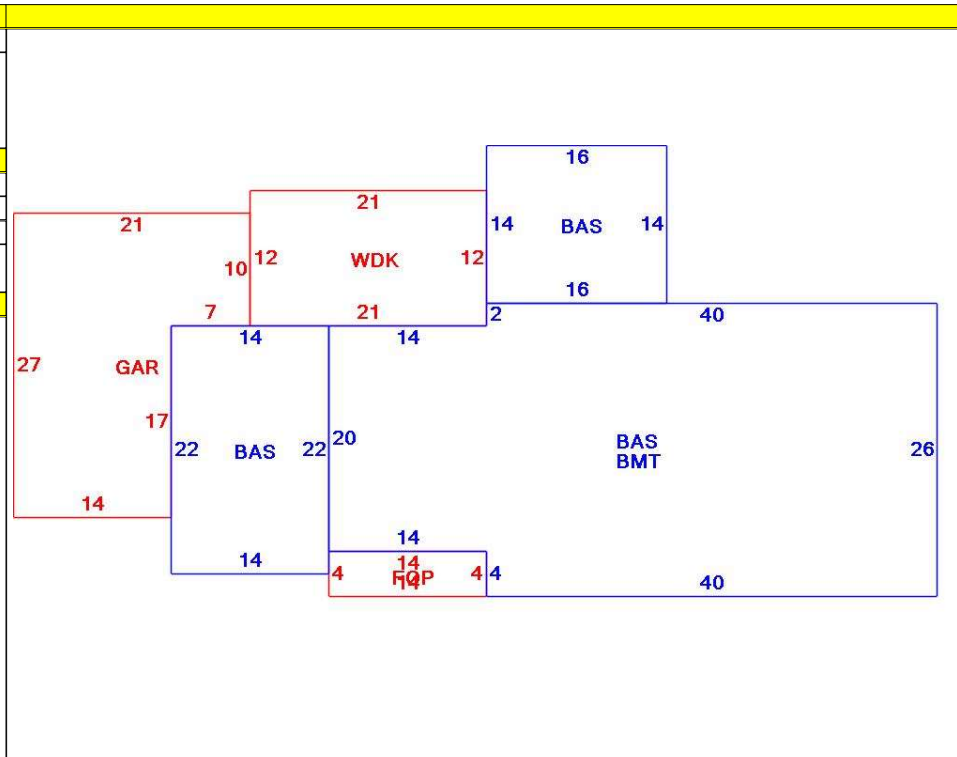

CONSTRUCTION DETAIL			CONSTRUCTION DETAIL (CONTINUED)		
Element	Cd	Description	Element	Cd	Description
Style	01	Ranch			
Model	01	Residential			
Grade:	C	Average			
Stories	1	1 Story			
Exterior Wall 1	14	Wood Shingle			
Exterior Wall 2					
RooF Structure	03	Gable/Hip			
RooF Cover	03	Asph/F Gls/Cmp			
Interior Wall 1	05	Drywall			
Interior Wall 2					
Interior Floor 1	12	Hardwood			
Interior Floor 2					
Heat Fuel	02	Oil			
Heat Type	05	Hot Water			
AC Type	01	None			
Bedrooms	02	2 Bedrooms			
Full Baths	3				
Half Baths	0				
Extra Fixtures					
Total Rooms	6	6 Rooms			
Bath Style					
Kitchen Style					
Occupancy					
Sewer Occupan					
Accessory Apt					
Foundation Alt	01	Poured Conc.			
Rms Prts					
Bath Split	30	3 Full-0 Half			

CONDO DATA			
Parcel Id		C	Owne 0.0
		B	S
Adjust Type	Code	Description	Factor%
Condo Flr			
Condo Unit			

COST / MARKET VALUATION	
Building Value New	494,743
Year Built	1977
Effective Year Built	1998
Depreciation Code	A
Remodel Rating	
Year Remodeled	
Depreciation %	20
Functional Obsol	0
External Obsol	0
Trend Factor	1
Condition	
Condition %	
Percent Good	80
RCNLD	395,800
Dep % Ovr	
Dep Ovr Comment	
Misc Imp Ovr	
Misc Imp Ovr Comment	
Cost to Cure Ovr	
Cost to Cure Ovr Comment	



OB - OUTBUILDING & YARD ITEMS(L) / XF - BUILDING EXTRA FEATURES(B)										
Code	Description	L/B	Units	Unit Price	Yr Blt	Cond. Cd	% Gd	Grade	Grade Adj.	Appr. Value
FPL1	Fireplace 1 sto	B	1	5000.00	1996		80		0.00	4,000
WDC	Wood Decking	L	252	20.00	1997		56		0.00	3,000
FOP	Open Porch-ro	B	56	55.00	1996		80		0.00	2,900
GAR	Attached Gara	B	448	40.00	1996		80		0.00	13,800
BMT	Basement-Unfi	B	1,320	26.01	1996		80		0.00	25,800
SOL1	Solar PV Pane	B	19	860.00	1996		0		0.00	0

BUILDING SUB-AREA SUMMARY SECTION						
Code	Description	Living Area	Floor Area	Eff Area	Unit Cost	Undeprec Value
BAS	First Floor	1,852	1,852	1,852	267.14	494,743
BMT	Basement Area	0	1,320	0	0.00	0
FOP	Open Porch	0	56	0	0.00	0
GAR	Attached Garage	0	448	0	0.00	0
WDK	Wood Deck	0	252	0	0.00	0
Ttl Gross Liv / Lease Area		1,852	3,928	1,852		494,743

