

CONSTRUCTION DETAIL			CONSTRUCTION DETAIL (CONTINUED)		
Element	Cd	Description	Element	Cd	Description
Style	03	Colonial			
Model	01	Residential			
Grade:	C	Average			
Stories	2	2 Stories			
Exterior Wall 1	11	Clapboard			
Exterior Wall 2	14	Wood Shingle			
RooF Structure	03	Gable/Hip			
RooF Cover	03	Asph/F Gls/Cmp			
Interior Wall 1	05	Drywall			
Interior Wall 2					
Interior Floor 1	14	Carpet			
Interior Floor 2					
Heat Fuel	03	Gas			
Heat Type	05	Hot Water			
AC Type	01	None			
Bedrooms	04	4 Bedrooms			
Full Baths	2				
Half Baths	1				
Extra Fixtures					
Total Rooms	10	10 Rooms			
Bath Style					
Kitchen Style					
Occupancy					
Sewer Occupan					
Accessory Apt					
Foundation Alt	01	Poured Conc.			
Rms Prts					
Bath Split	21	2 Full-1 Half			

CONDO DATA				
Parcel Id		C	Owne	0.0
Adjust Type	Code	Description	Factor%	
Condo Flr				
Condo Unit				

COST / MARKET VALUATION		
Building Value New		539,906
Year Built		1977
Effective Year Built		2003
Depreciation Code		G
Remodel Rating		
Year Remodeled		
Depreciation %		16
Functional Obsol		0
External Obsol		0
Trend Factor		1
Condition		
Condition %		
Percent Good		84
RCNLD		453,500
Dep % Ovr		
Dep Ovr Comment		
Misc Imp Ovr		
Misc Imp Ovr Comment		
Cost to Cure Ovr		
Cost to Cure Ovr Comment		

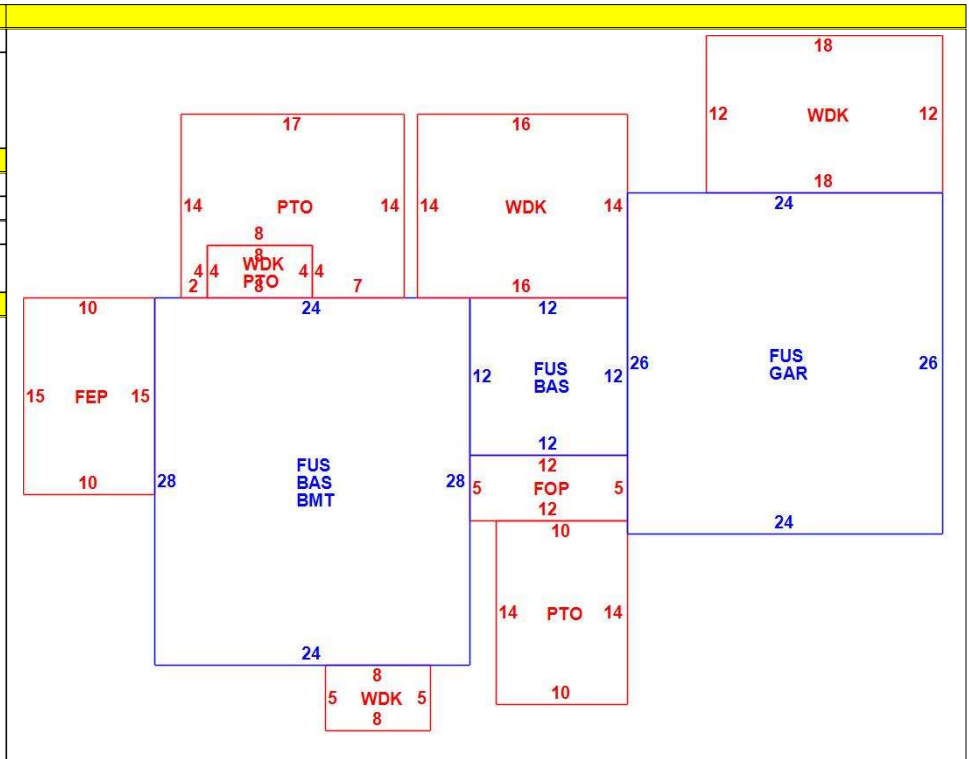

OB - OUTBUILDING & YARD ITEMS(L) / XF - BUILDING EXTRA FEATURES(B)										
Code	Description	L/B	Units	Unit Price	Yr Blt	Cond. Cd	% Gd	Grade	Grade Adj.	Appr. Value
FPL3	Fireplace 2 sto	B	1	7000.00	2001		84		0.00	5,900
WDC	Wood Decking	L	512	20.00	2002		66		0.00	6,300
PAT2	Patio-Good	L	378	9.94	2002		83		0.00	3,100
FOP	Open Porch-ro	B	60	55.00	2001		84		0.00	3,200
FEP	Enclosed porc	B	150	70.00	2001		84		0.00	8,800
GAR	Attached Gara	B	624	40.00	2001		84		0.00	18,200
BMT	Basement-Unfi	B	672	26.01	2001		84		0.00	17,300

BUILDING SUB-AREA SUMMARY SECTION						
Code	Description	Living Area	Floor Area	Eff Area	Unit Cost	Undeprec Value
BAS	First Floor	816	816	816	239.32	195,285
BMT	Basement Area	0	672	0	0.00	0
FEP	Enclosed Porch	0	150	0	0.00	0
FOP	Open Porch	0	60	0	0.00	0
FUS	Upper Story	1,440	1,440	1,440	239.32	344,621
GAR	Attached Garage	0	624	0	0.00	0
PTO	Patio	0	378	0	0.00	0
WDK	Wood Deck	0	512	0	0.00	0
Ttl Gross Liv / Lease Area		2,256	4,652	2,256		539,906

