

| CURRENT OWNER | | TOPO | UTILITIES | STRT / ROAD | LOCATION | CURRENT ASSESSMENT | | | | 801 FY2025 BARNSTABLE, MA VISION |
|--|--|---------|----------------|--|----------|--------------------|------|----------|----------|--|
| BROWN, DAVID B & NANCY P TRS DAVID B BROWN LIVING TRUST 15 JUDITH EVE LANE CENTERVILLE MA 02632 | | 1 Level | 2 Public Water | 1 Paved | | Description | Code | Assessed | Assessed | |
| | | | 4 Gas | | | RESIDNTL | 1010 | 638,600 | 638,600 | |
| | | | 6 Septic | | 3 | RES LAND | 1010 | 151,900 | 151,900 | |
| SUPPLEMENTAL DATA | | | | | | Total | | | | |
| Alt Prcl ID Split Zonin BID Parcel ResExpt Q YES: #DL 1 LOT 14 #DL 2 GIS ID F_969193_2708705 | | | | Plan Ref. 326/27 Land Ct# #SR Life Estate PP STATU Assoc Pid# | | 790,500 | | | | 790,500 |

| RECORD OF OWNERSHIP | | BK-VOL/PAGE | SALE DATE | Q/U | V/I | SALE PRIC | VC | PREVIOUS ASSESSMENTS (HISTORY) | | | | | | | | |
|------------------------------|--|-------------|------------|-----|-----|-----------|----|--------------------------------|------|----------|------|---------|----------|-------|------|----------|
| BROWN, DAVID B & NANCY P TRS | | 22463 0101 | 11-09-2007 | U | I | 1 | 1A | Year | Code | Assessed | Year | Code | Assessed | Year | Code | Assessed |
| BROWN, DAVID B | | 6791 0266 | 06-15-1989 | U | I | 225,000 | D | 2025 | 1010 | 638,600 | 2024 | 1010 | 604,700 | 2023 | 1010 | 543,400 |
| SAURO, DAVID A TR | | 6515 0280 | 11-15-1988 | Q | V | 67,500 | U | | 1010 | 151,900 | | 1010 | 151,900 | | 1010 | 138,100 |
| RYAN, ROSEMARY | | 4423 0331 | 02-15-1985 | Q | V | 31,250 | U | | | | | | | | | |
| DUFF, STEPHEN A | | 4097 0149 | 05-15-1984 | Q | V | 22,500 | U | | | | | | | | | |
| Total | | | | | | | | 790,500 | | Total | | 756,600 | | Total | | 681,500 |

| EXEMPTIONS | | | | OTHER ASSESSMENTS | | | | This signature acknowledges a visit by a Data Collector or Assessor | | | | | | | | |
|------------|------|-----------------------|--------|-------------------|-------------|--------|--------|---|--|--|--|--|--|--|--|--|
| Year | Code | Description | Amount | Code | Description | Number | Amount | Comm Int | | | | | | | | |
| 2017 | 5C | RESIDENTIAL EXEMPTION | 0.00 | | | | | | | | | | | | | |
| Total | | | 0.00 | | | | | | | | | | | | | |

| ASSESSING NEIGHBORHOOD | | | | APPRAISED VALUE SUMMARY | | | | | | | | |
|------------------------|-----------|--|---|-------------------------|--|-------|--|-------------------------------|--|--|--|---------|
| Nbhd | Nbhd Name | | B | Tracing | | Batch | | | | | | |
| 0105 | | | | CENVIL | | | | | | | | |
| NOTES | | | | | | | | | | | | |
| | | | | | | | | Appraised Bldg. Value (Card) | | | | 568,500 |
| | | | | | | | | Appraised Xf (B) Value (Bldg) | | | | 63,900 |
| | | | | | | | | Appraised Ob (B) Value (Bldg) | | | | 6,200 |
| | | | | | | | | Appraised Land Value (Bldg) | | | | 151,900 |
| | | | | | | | | Special Land Value | | | | 0 |
| | | | | | | | | Total Appraised Parcel Value | | | | 790,500 |
| | | | | | | | | Valuation Method | | | | C |
| | | | | | | | | Total Appraised Parcel Value | | | | 790,500 |

| BUILDING PERMIT RECORD | | | | | | | | VISIT / CHANGE HISTORY | | | | | | | |
|------------------------|------------|------|-------------|---------|------------|--------|-----------|------------------------|------------|----|------|----|----|----------------------------|--|
| Permit Id | Issue Date | Type | Description | Amount | Insp Date | % Comp | Date Comp | Comments | Date | Id | Type | Is | Cd | Purpost/Result | |
| B35874 | 05-01-1993 | AD | Addition | 15,000 | 01-15-1994 | 100 | | CE ADDIT' | 06-10-2020 | SR | 01 | | 03 | Cycl Insp Comp | |
| B32902 | 05-01-1989 | DW | Dwelling | 100,000 | 01-15-1990 | 100 | | CE 11/2 S | 04-17-2020 | LS | | | FR | Field Review | |
| | | | | | | | | | 02-06-2017 | GC | 03 | | 16 | In Office Review | |
| | | | | | | | | | 08-27-2014 | JR | 03 | | 16 | In Office Review | |
| | | | | | | | | | 11-27-2000 | PT | 01 | | 00 | Meas/Listed-Interior Acces | |
| | | | | | | | | | 03-15-1990 | ME | 02 | | 01 | Meas/Est | |

| LAND LINE VALUATION SECTION | | | | | | | | | | | | | | | | | |
|-----------------------------|----------|----------------|------|----|------------|------------------------|----------|---------|------------|-------|-------|------------------|-------|--------------------|------------|------------|---------|
| B | Use Code | Description | Zone | LA | Land Units | Unit Price | Size Adj | AC Disc | Site Index | Cond. | Nbhd. | Nbhd. Adj | Notes | Location Adjustmen | Adj Unit P | Land Value | |
| 1 | 1010 | Single Fam M-0 | RC | 3 | 0.340 AC | 176,344.00 | 2.53383 | 1.0000 | 5 | 1.00 | 0105 | 1.000 | | 1.0000 | 446,820.4 | 151,900 | |
| Total Card Land Units | | | | | 0.34 AC | Parcel Total Land Area | | | | | 0.34 | Total Land Value | | | | | 151,900 |

| CONSTRUCTION DETAIL | | | CONSTRUCTION DETAIL (CONTINUED) | | |
|---------------------|------|----------------|--------------------------------------|----|-------------|
| Element | Cd | Description | Element | Cd | Description |
| Style | 04 | Cape Cod | | | |
| Model | 01 | Residential | | | |
| Grade: | C+ | Average Plus | | | |
| Stories | 1.75 | 1 3/4 Stories | | | |
| Exterior Wall 1 | 14 | Wood Shingle | | | |
| Exterior Wall 2 | | | | | |
| RooF Structure | 03 | Gable/Hip | | | |
| RooF Cover | 03 | Asph/F Gls/Cmp | | | |
| Interior Wall 1 | 05 | Drywall | | | |
| Interior Wall 2 | | | | | |
| Interior Floor 1 | 14 | Carpet | | | |
| Interior Floor 2 | 12 | Hardwood | | | |
| Heat Fuel | 03 | Gas | | | |
| Heat Type | 05 | Hot Water | | | |
| AC Type | 03 | Central | | | |
| Bedrooms | 03 | 3 Bedrooms | | | |
| Full Baths | 2 | | | | |
| Half Baths | 1 | | | | |
| Extra Fixtures | | | | | |
| Total Rooms | 7 | 7 Rooms | | | |
| Bath Style | | | | | |
| Kitchen Style | | | | | |
| Occupancy | | | | | |
| Sewer Occupan | | | | | |
| Accessory Apt | | | | | |
| Foundation Alt | 01 | Poured Conc. | | | |
| Rms Prts | | | | | |
| Bath Split | 21 | 2 Full-1 Half | | | |
| | | | CONDO DATA | | |
| | | | Parcel Id | C | Owne 0.0 |
| | | | Adjust Type Code Description Factor% | | |
| | | | Condo Flr | | |
| | | | Condo Unit | | |
| | | | COST / MARKET VALUATION | | |
| | | | Building Value New | | 676,762 |
| | | | Year Built | | 1989 |
| | | | Effective Year Built | | 2004 |
| | | | Depreciation Code | | A |
| | | | Remodel Rating | | |
| | | | Year Remodeled | | |
| | | | Depreciation % | | 16 |
| | | | Functional Obsol | | 0 |
| | | | External Obsol | | 0 |
| | | | Trend Factor | | 1 |
| | | | Condition | | |
| | | | Condition % | | |
| | | | Percent Good | | 84 |
| | | | RCNLD | | 568,500 |
| | | | Dep % Ovr | | |
| | | | Dep Ovr Comment | | |
| | | | Misc Imp Ovr | | |
| | | | Misc Imp Ovr Comment | | |
| | | | Cost to Cure Ovr | | |
| | | | Cost to Cure Ovr Comment | | |

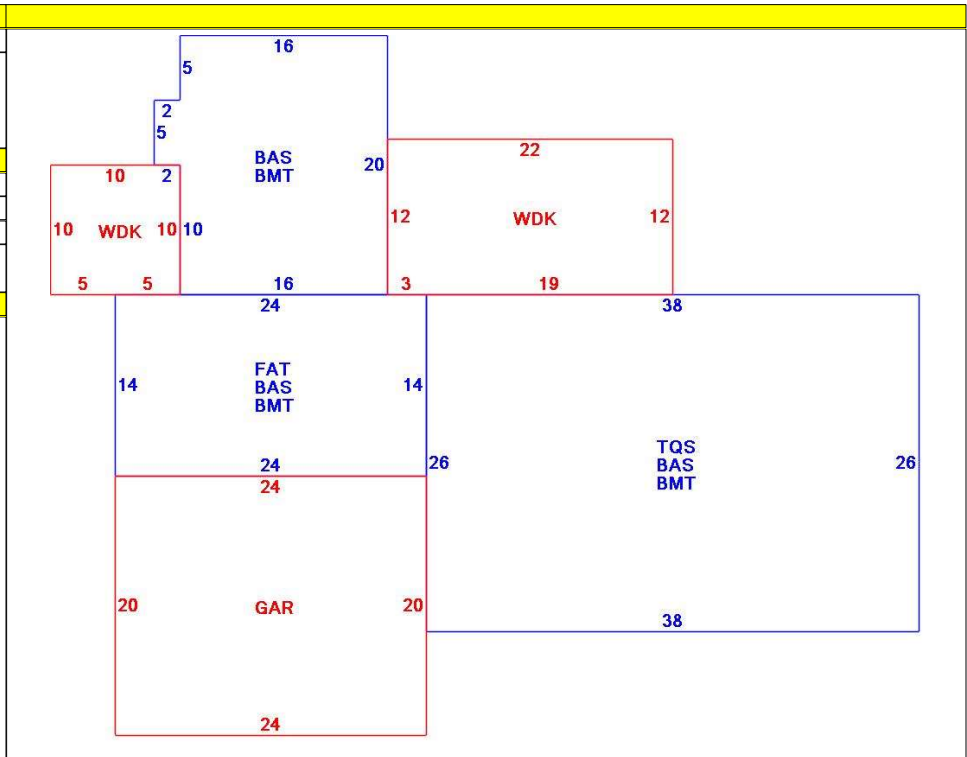

| OB - OUTBUILDING & YARD ITEMS(L) / XF - BUILDING EXTRA FEATURES(B) | | | | | | | | | | |
|--|-----------------|-----|-------|------------|--------|----------|------|-------|------------|-------------|
| Code | Description | L/B | Units | Unit Price | Yr Blt | Cond. Cd | % Gd | Grade | Grade Adj. | Appr. Value |
| FPL2 | Fireplace 1.5 s | B | 1 | 6000.00 | 2002 | | 84 | | 0.00 | 5,000 |
| BFA | Bsmt Fin-Avg | B | 800 | 17.36 | 2002 | | 84 | | 0.00 | 11,700 |
| WDC | Deck comp w | L | 364 | 28.00 | 2000 | | 62 | | 0.00 | 6,200 |
| GAR | Attached Gara | B | 480 | 40.00 | 2002 | | 84 | | 0.00 | 15,200 |
| BMT | Basement-Unfi | B | 1,654 | 26.01 | 2002 | | 84 | | 0.00 | 32,000 |

| BUILDING SUB-AREA SUMMARY SECTION | | | | | | |
|-----------------------------------|---------------------|-------------|------------|----------|-----------|----------------|
| Code | Description | Living Area | Floor Area | Eff Area | Unit Cost | Undeprec Value |
| BAS | First Floor | 1,654 | 1,654 | 1,654 | 288.48 | 477,138 |
| BMT | Basement Area | 0 | 1,654 | 0 | 0.00 | 0 |
| FAT | Attic, Finished | 50 | 336 | 50 | 42.93 | 14,424 |
| GAR | Attached Garage | 0 | 480 | 0 | 0.00 | 0 |
| TQS | Three Quarter Story | 642 | 988 | 642 | 187.45 | 185,201 |
| WDK | Wood Deck | 0 | 364 | 0 | 0.00 | 0 |
| Ttl Gross Liv / Lease Area | | 2,346 | 5,476 | 2,346 | | 676,763 |

