

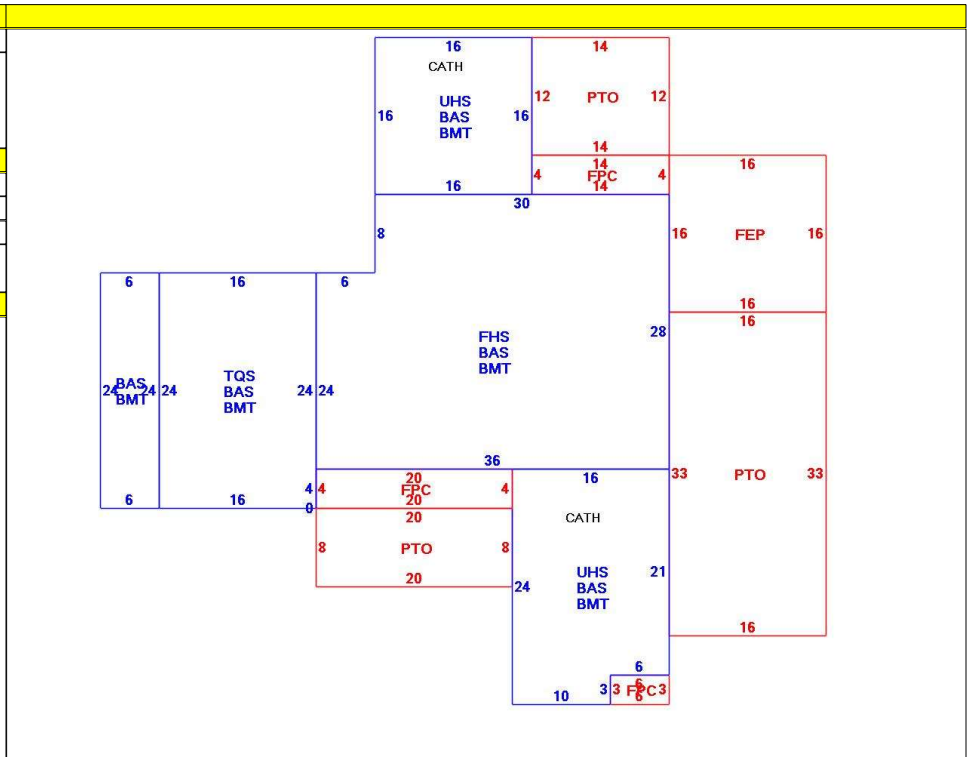

CONSTRUCTION DETAIL			CONSTRUCTION DETAIL (CONTINUED)		
Element	Cd	Description	Element	Cd	Description
Style	07	Modern/Contemp			
Model	01	Residential			
Grade:	C+	Average Plus			
Stories	1.5	1 1/2 Stories			
Exterior Wall 1	11	Clapboard			
Exterior Wall 2					
RooF Structure	03	Gable/Hip			
RooF Cover	03	Asph/F Gls/Cmp			
Interior Wall 1	05	Drywall			
Interior Wall 2					
Interior Floor 1	14	Carpet			
Interior Floor 2	12	Hardwood			
Heat Fuel	03	Gas			
Heat Type	04	Hot Air			
AC Type	03	Central			
Bedrooms	03	3 Bedrooms			
Full Baths	2				
Half Baths	1				
Extra Fixtures					
Total Rooms	7	7 Rooms			
Bath Style					
Kitchen Style					
Occupancy					
Sewer Occupan					
Accessory Apt					
Foundation Alt	01	Poured Conc.			
Rms Prts					
Bath Split	21	2 Full-1 Half			
<b>CONDO DATA</b>			<b>COST / MARKET VALUATION</b>		
Parcel Id		C	Ownr	0.0	
Adjust Ttp	Code	Description	Factor%		
Condo Flr					
Condo Unit					
Building Value New		738,527			
Year Built		1985			
Effective Year Built		2002			
Depreciation Code		A			
Remodel Rating					
Year Remodeled					
Depreciation %		17			
Functional Obsol		0			
External Obsol		0			
Trend Factor		1			
Condition					
Condition %					
Percent Good		83			
RCNLD		613,000			
Dep % Ovr					
Dep Ovr Comment					
Misc Imp Ovr					
Misc Imp Ovr Comment					
Cost to Cure Ovr					
Cost to Cure Ovr Comment					



OB - OUTBUILDING & YARD ITEMS(L) / XF - BUILDING EXTRA FEATURES(B)										
Code	Description	L/B	Units	Unit Price	Yr Blt	Cond. Cd	% Gd	Grade	Grade Adj.	Appr. Value
FPL2	Fireplace 1.5 s	B	1	6000.00	2000		83		0.00	5,000
BGR2	2 Stall Bmt Ga	B	1	3244.00	2000		83		0.00	2,700
PAT2	Patio-Good	L	528	9.94	1999		80		0.00	4,100
FOPC	Open Prch-roo	B	154	55.00	2000		83		0.00	5,200
FEP	Enclosed porc	B	256	70.00	2000		83		0.00	12,200
BMT	Basement-Unfi	B	2,110	26.01	2000		83		0.00	38,800
FPO	Ext FP Openin	B	1	2000.00	2000		83		0.00	1,700
PATC	Conc Pavers	L	328	15.46	2018		99		0.00	5,000
FPIT	Fire Pit	L	1	3010.00	2018		94	C	1.00	2,800
GEN	Emergency Ge	L	1	5550.00	2018		98		0.00	5,400

BUILDING SUB-AREA SUMMARY SECTION						
Code	Description	Living Area	Floor Area	Eff Area	Unit Cost	Undeprec Value
BAS	First Floor	2,110	2,110	2,110	243.98	514,798
BMT	Basement Area	0	2,110	0	0.00	0
FEP	Enclosed Porch	0	256	0	0.00	0
FHS	Half Story	480	960	480	121.99	117,110
FPC	Open Porch Conc. Floor	0	154	0	0.00	0
PTO	Patio	0	856	0	0.00	0
TQS	Three Quarter Story	250	384	250	158.84	60,995
UHS	Half Story, Unfinished	0	622	187	73.35	45,624
Ttl Gross Liv / Lease Area		2,840	7,452	3,027		738,527

