

CURRENT OWNER		TOPO	UTILITIES	STRT / ROAD	LOCATION	CURRENT ASSESSMENT				
MAYO, WALTER L III & SARAH N TRS					1 Lake/Pond Fro	Description	Code	Assessed	Assessed	801 FY2025 BARNSTABLE, MA
MAYO INVESTMENT TRUST					3	RESIDENTL	1010	653,200	653,200	
92 PHINNEY'S LANE						RES LAND	1010	608,500	608,500	
SUPPLEMENTAL DATA										
CENTERVILLE MA 02632		Alt Prcl ID Split Zonin BID Parcel ResExpt Q YES: #DL 1 LOT B #DL 2			Plan Ref. 118/11 Land Ct# #SR Life Estate PP STATU		Total		1,261,700	1,261,700

VISION

RECORD OF OWNERSHIP		BK-VOL/PAGE	SALE DATE	Q/U	V/I	SALE PRIC	VC	PREVIOUS ASSESSMENTS (HISTORY)						
MAYO, WALTER L III & SARAH N TRS		27709 0347	09-24-2013	U	I	1	1F	Year	Code	Assessed	Year	Code	Assessed	
MAYO, WALTER L III & SARAH N		24733 0161	08-06-2010	Q	I	839,000	00	2025	1010	653,200	2024	1010	617,300	
NARDINI, DANIEL N & LUCILLE		10258 0083	06-15-1996	Q	I	207,500	U		1010	608,500	2023	1010	624,400	
FULLER, ALLEN W & BONNIE E		6674 0298	03-28-1989	U	I	1	A						712,000	
FULLER, ALLEN W		6547 0039	12-07-1988	U		0	1							
Total								1,261,700			Total	1,215,900	Total	1,336,400

EXEMPTIONS				OTHER ASSESSMENTS				APPRaised VALUE SUMMARY				
Year	Code	Description	Amount	Code	Description	Number	Amount	Comm Int	This signature acknowledges a visit by a Data Collector or Assessor			
2023	5C	RESIDENTIAL EXEMPTION							Appraised Bldg. Value (Card) 503,500			
Total			0.00					Appraised Xf (B) Value (Bldg) 115,700				

ASSESSING NEIGHBORHOOD		B		Tracing		Batch	
Nbhd	Nbhd Name	B		Tracing		Batch	
0110						CENVIL	

NOTES													
Total Appraised Parcel Value												1,261,700	

BUILDING PERMIT RECORD									VISIT / CHANGE HISTORY					
Permit Id	Issue Date	Type	Description	Amount	Insp Date	% Comp	Date Comp	Comments	Date	Id	Type	Is	Cd	Purpost/Result
EXPR-22-1	10-06-2022	835	Sid/Wind/Roof/	3,862		100		Weatherization and air sealin	01-25-2023	JO	03		16	In Office Review
201500211	01-29-2015	PVC	Solar PV Comm	45,370	05-13-2015	100	06-30-2015	INSTALLATION OF 33 FLUSH	10-11-2022	JO			16	In Office Review
201205549	09-08-2012	AD	Addition	85,000	09-12-2013	100	09-12-2013	KIT BUMP-OUT-EXPAND FN	06-05-2020	LS			FR	Field Review
201201011	03-23-2012	RE	Remodel	150,000	09-12-2013	100	09-12-2013	INTER RENO-REBLD FIREPL	08-27-2018	EO	03		16	In Office Review
37341	03-25-1999	AD	Addition	40,000	01-01-2000	100	06-30-2000	BREAKFAST ROOM	10-02-2015	NF	03		16	In Office Review
35350	12-14-1998	RE	Remodel	0	01-01-2000	100	06-30-2000	CHANGE OF USE	07-20-2015	TP	03		16	In Office Review
18423	10-07-1996	AD	Addition	95,040	01-01-1999	100	06-30-1999		05-21-2015	SR	02		02	Bldg Permit Completed

LAND LINE VALUATION SECTION																
B	Use Code	Description	Zone	LA	Land Units	Unit Price	Size Adj	AC Disc	Site Index	Cond.	Nbhd.	Nbhd. Adj	Notes	Location Adjustmen	Adj Unit P	Land Value
1	1010	Single Fam M-0	RD-	3	1.000	AC 176,344.00	1.00000	1.0000	5	1.00	0110	3.100	LONG POND		1.0000	546,666.4
1	1010	Single Fam M-0	RD-	3	1.400	AC 14,250.00	1.00000	1.0000	0	1.00	0110	3.100			1.0000	44,175
Total Card Land Units					2.40	AC	Parcel Total Land Area					2.40	Total Land Value			608,500

CONSTRUCTION DETAIL			CONSTRUCTION DETAIL (CONTINUED)		
Element	Cd	Description	Element	Cd	Description
Style	11	Family Conver.			
Model	01	Residential			
Grade:	C+	Average Plus			
Stories	2	2 Stories			
Exterior Wall 1	25	Vinyl Siding			
Exterior Wall 2	11	Clapboard			
RooF Structure	03	Gable/Hip			
RooF Cover	03	Asph/F Gls/Cmp			
Interior Wall 1	05	Drywall			
Interior Wall 2					
Interior Floor 1	11	Ceram Clay Til			
Interior Floor 2	12	Hardwood			
Heat Fuel	03	Gas			
Heat Type	04	Hot Air			
AC Type	03	Central			
Bedrooms	05	5 Bedrooms			
Full Baths	6				
Half Baths	0				
Extra Fixtures					
Total Rooms	9				
Bath Style					
Kitchen Style					
Occupancy					
Sewer Occupan					
Accessory Apt					
Foundation Alt	01	Poured Conc.			
Rms Prts					
Bath Split	60	6 Full-0 Half			

CONDO DATA				
Parcel Id		C		Owne 0.0
Adjust Type	Code	Description	Factor%	
Condo Flr				
Condo Unit				

COST / MARKET VALUATION		
Building Value New		599,435
Year Built		1947
Effective Year Built		2004
Depreciation Code		E
Remodel Rating		
Year Remodeled		
Depreciation %		16
Functional Obsol		0
External Obsol		0
Trend Factor		1
Condition		
Condition %		
Percent Good		84
RCNLD		503,500
Dep % Ovr		
Dep Ovr Comment		
Misc Imp Ovr		
Misc Imp Ovr Comment		
Cost to Cure Ovr		
Cost to Cure Ovr Comment		

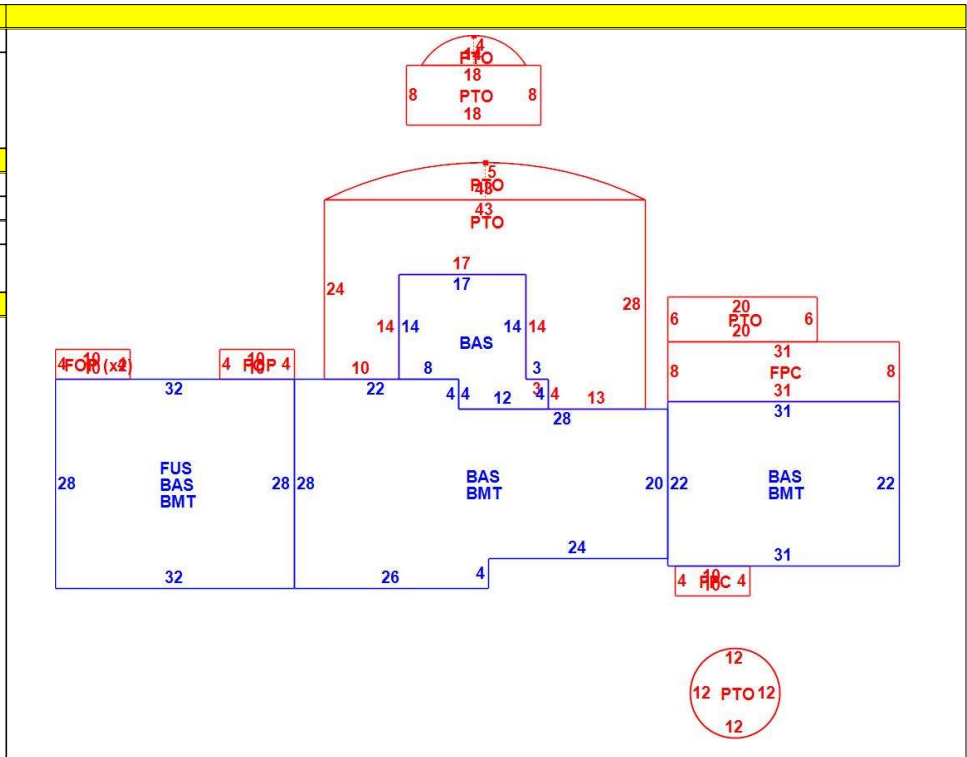

OB - OUTBUILDING & YARD ITEMS(L) / XF - BUILDING EXTRA FEATURES(B)

Code	Description	L/B	Units	Unit Price	Yr Blt	Cond. Cd	% Gd	Grade	Grade Adj.	Appr. Value
FPL1	Fireplace 1 sto	B	1	5000.00	2001		84		0.00	4,200
FPO	Ext FP Openin	B	2	2000.00	2001		84		0.00	3,400
FOP	Open Porch-ro	B	120	55.00	2001		84		0.00	5,300
BMT	Basement-Unfi	B	2,770	26.01	2001		84		0.00	49,000
DKPL	Pond Dock-Lig	L	1	4200.00	1990		100		0.00	4,200
BGR2	2 Stall Brnt Ga	B	1	3244.00	2001		84		0.00	2,700
PATF	Flagstone Pav	L	1,295	30.00	1997		78		0.00	26,400
FOPC	Open Prch-roo	B	288	55.00	2001		84		0.00	9,300
FPLG	Gas Fireplace-	B	2	2500.00	2001		84		0.00	4,200
BFA1	Bsmt Fin-Goo	B	1,374	32.56	2001		84		0.00	37,600

BUILDING SUB-AREA SUMMARY SECTION

Code	Description	Living Area	Floor Area	Eff Area	Unit Cost	Undeprec Value
BAS	First Floor	3,056	3,056	3,056	151.68	463,531
BMT	Basement Area	0	2,770	0	0.00	0
FOP	Open Porch	0	120	0	0.00	0
FPC	Open Porch Conc. Floor	0	288	0	0.00	0
FUS	Upper Story	896	896	896	151.68	135,904
PTO	Patio	0	1,408	0	0.00	0
Ttl Gross Liv / Lease Area		3,952	8,538	3,952		599,435



CURRENT OWNER		TOPO	UTILITIES	STRT / ROAD	LOCATION	CURRENT ASSESSMENT			
MAYO, WALTER L III & SARAH N TRS					1 Lake/Pond Fro	Description	Code	Assessed	Assessed
MAYO INVESTMENT TRUST					3	RESIDNTL	1010	653,200	653,200
92 PHINNEY'S LANE		SUPPLEMENTAL DATA				RES LAND	1010	608,500	608,500
CENTERVILLE MA 02632		Alt Prcl ID Split Zonin BID Parcel ResExpt Q YES: #DL 1 LOT B #DL 2 GIS ID F_972674_2701381		Plan Ref. 118/11 Land Ct# #SR Life Estate PP STATU Assoc Pid#		Total 1,261,700 1,261,700			

801
FY2025
BARNSTABLE, MA

VISION

RECORD OF OWNERSHIP		BK-VOL/PAGE	SALE DATE	Q/U	V/I	SALE PRIC	VC	PREVIOUS ASSESSMENTS (HISTORY)					
								Year	Code	Assessed	Year	Code	Assessed
								2025	1010	653,200	2024	1010	617,300
									1010	608,500		1010	598,600
								Total		1,261,700	Total		1,215,900
								Total			Total		1,336,400

EXEMPTIONS			OTHER ASSESSMENTS					
Year	Code	Description	Amount	Code	Description	Number	Amount	Comm Int
Total								

This signature acknowledges a visit by a Data Collector or Assessor

ASSESSING NEIGHBORHOOD			
Nbhd	Nbhd Name	B	Tracing
0110			CENVIL

NOTES			

APPRAISED VALUE SUMMARY	
Appraised Bldg. Value (Card)	503,500
Appraised Xf (B) Value (Bldg)	115,700
Appraised Ob (B) Value (Bldg)	34,000
Appraised Land Value (Bldg)	608,500
Special Land Value	0
Total Appraised Parcel Value	1,261,700
Valuation Method	C
Total Appraised Parcel Value	1,261,700

BUILDING PERMIT RECORD							VISIT / CHANGE HISTORY							
Permit Id	Issue Date	Type	Description	Amount	Insp Date	% Comp	Date Comp	Comments	Date	Id	Type	Is	Cd	Purpost/Result

LAND LINE VALUATION SECTION																
B	Use Code	Description	Zone	LA	Land Units	Unit Price	Size Adj	AC Disc	Site Index	Cond.	Nbhd.	Nbhd. Adj	Notes	Location Adjustmen	Adj Unit P	Land Value
Total Card Land Units					Parcel Total Land Area					Total Land Value						

CONSTRUCTION DETAIL						CONSTRUCTION DETAIL (CONTINUED)					
Element	Cd	Description				Element	Cd	Description			
Style	11	Family Conver.									
Model	01	Residential									
Grade:	C+	Average Plus									
Stories	2	2 Stories									
Exterior Wall 1	25	Vinyl Siding				CONDO DATA					
Exterior Wall 2	11	Clapboard				Parcel Id		C		Ownr	0.0
Roof Structure	03	Gable/Hip							B		S
Roof Cover	03	Asph/F Gls/Cmp				Adjust Type	Code	Description		Factor%	
Interior Wall 1	05	Drywall				Condo Flr					
Interior Wall 2						Condo Unit					
Interior Floor 1	11	Ceram Clay Til				COST / MARKET VALUATION					
Interior Floor 2	12	Hardwood				Building Value New					
Heat Fuel	03	Gas				Year Built					
Heat Type	04	Hot Air				Effective Year Built					
AC Type	03	Central				Depreciation Code					
Bedrooms	05	5 Bedrooms				Remodel Rating					
Full Baths	6					Year Remodeled					
Half Baths	0					Depreciation %					
Extra Fixtures						Functional Obsol					
Total Rooms	9					External Obsol					
Bath Style						Trend Factor					
Kitchen Style						Condition					
Occupancy						Condition %					
Sewer Occupan						Percent Good					
Accessory Apt						RCNLD					
Foundation Alt	01	Poured Conc.				Dep % Ovr					
Rms Prts						Dep Ovr Comment					
Bath Split	60	6 Full-0 Half				Misc Imp Ovr					
						Misc Imp Ovr Comment					
						Cost to Cure Ovr					
						Cost to Cure Ovr Comment					
OB - OUTBUILDING & YARD ITEMS(L) / XF - BUILDING EXTRA FEATURES(B)											
Code	Description	L/B	Units	Unit Price	Yr Blt	Cond. Cd	% Gd	Grade	Grade Adj.	Appr. Value	
PATF	Flagstone Pav	L	113	30.00	2003		84		0.00	3,400	
SOLF	Solar PV Watt-	B	9,000	1.50	2001		0	00	1.00	0	
BUILDING SUB-AREA SUMMARY SECTION											
Code	Description	Living Area	Floor Area	Eff Area	Unit Cost	Undeprec Value					
Ttl Gross Liv / Lease Area											