

CURRENT OWNER		TOPO	UTILITIES	STRT / ROAD	LOCATION	CURRENT ASSESSMENT				
EDWARDS, MARK TR BONITA MARIE LESLIE TRUST 226 MAIN STREET						Description	Code	Assessed	Assessed	801 FY2025 BARNSTABLE, MA
CENTERVILLE MA 02632					3	RESIDNTL	1010	1,016,700	1,016,700	
SUPPLEMENTAL DATA										VISION
Alt Prcl ID				Plan Ref. 315/22; 434/68						
Split Zonin				Land Ct#						
BID Parcel				#SR						
ResExpt Q				Life Estate						
#DL 1 LOT 11A; PARCELA				PP STATU						
#DL 2										
GIS ID F_971875_2700994				Assoc Pid#						
						Total		1,197,400	1,197,400	

RECORD OF OWNERSHIP		BK-VOL/PAGE	SALE DATE	Q/U	V/I	SALE PRIC	VC	PREVIOUS ASSESSMENTS (HISTORY)					
EDWARDS, MARK TR		35660 153	05-11-2022	U	I	0	1F	Year	Code	Assessed	Year	Code	Assessed
LESLIE, BONITA TR		29033 0074	07-24-2015	U	I	1	1F	2025	1010	1,016,700	2024	1010	964,600
LESLIE, BONITA M		9753 0273	07-15-1995	U	I	100	1F		1010	180,700	2023	1010	862,200
LESLIE, EDWARD E & BONITA		5799 0254	06-26-1987	Q	I	1	U					1010	178,600
LESLIE, EDWARD E & BONITA		5771 0110	06-11-1987	U		0		Total		1,197,400	Total		1,145,300
						Total		Total		1,145,300	Total		1,040,800

EXEMPTIONS			OTHER ASSESSMENTS					
Year	Code	Description	Amount	Code	Description	Number	Amount	Comm Int
Total			0.00					

ASSESSING NEIGHBORHOOD		
Nbhd	Nbhd Name	B
0106		

NOTES	
This signature acknowledges a visit by a Data Collector or Assessor	

BUILDING PERMIT RECORD									VISIT / CHANGE HISTORY					
Permit Id	Issue Date	Type	Description	Amount	Insp Date	% Comp	Date Comp	Comments	Date	Id	Type	Is	Cd	Purpost/Result
16-928	04-14-2016	835	Sid/Wind/Roof/	9,800	06-30-2016	100	06-30-2016	Reroof (rubber) Stripping old s	04-20-2021	SR	01		03	Cycl Insp Comp
72941	11-13-2003	RE	Remodel	60,000	06-08-2004	100	01-01-2004		06-05-2020	LS			FR	Field Review
B30405	02-01-1987	AD	Addition	200,000	01-15-1988	100		CE ADD'N	07-24-2015	AL	03		16	In Office Review
B27595	03-01-1985	SP	Swimming Pool	20,000	09-15-1986	100		CE POOL	05-12-2015	JR	03		03	Cycl Insp Comp
									06-08-2004	MF	02		01	Meas/Est
									07-12-2002	PT	02		01	Meas/Est
									11-01-1996	LK	02		01	Meas/Est

LAND LINE VALUATION SECTION																	
B	Use Code	Description	Zone	LA	Land Units	Unit Price	Size Adj	AC Disc	Site Index	Cond.	Nbhd.	Nbhd. Adj	Notes	Location Adjustmen	Adj Unit P	Land Value	
1	1010	Single Fam M-0	RC	3	0.500 AC	176,344.00	1.78240	1.0000	5	1.00	0106	1.150		1.0000	361,469.9	180,700	
Total Card Land Units					0.50 AC	Parcel Total Land Area					0.50	Total Land Value					180,700

CONSTRUCTION DETAIL			CONSTRUCTION DETAIL (CONTINUED)		
Element	Cd	Description	Element	Cd	Description
Style	04	Cape Cod			
Model	01	Residential			
Grade:	C+	Average Plus			
Stories	1.75	1 3/4 Stories			
Exterior Wall 1	14	Wood Shingle			
Exterior Wall 2					
RooF Structure	03	Gable/Hip			
RooF Cover	10	Wood Shingle			
Interior Wall 1	03	Plastered			
Interior Wall 2	05	Drywall			
Interior Floor 1	14	Carpet			
Interior Floor 2	12	Hardwood			
Heat Fuel	03	Gas			
Heat Type	04	Hot Air			
AC Type	03	Central			
Bedrooms	04	4 Bedrooms			
Full Baths	2				
Half Baths	1				
Extra Fixtures					
Total Rooms	8	8 Rooms			
Bath Style					
Kitchen Style					
Occupancy					
Sewer Occupan					
Accessory Apt					
Foundation Alt	01	Poured Conc.			
Rms Prts					
Bath Split	21	2 Full-1 Half			
			CONDO DATA		
			Parcel Id	C	Ownr 0.0
			COST / MARKET VALUATION		
			Building Value New	1,076,432	
			Year Built	1978	
			Effective Year Built	1999	
			Depreciation Code	A	
			Remodel Rating		
			Year Remodeled		
			Depreciation %	19	
			Functional Obsol	0	
			External Obsol	0	
			Trend Factor	1	
			Condition		
			Condition %		
			Percent Good	81	
			RCNLD	871,900	
			Dep % Ovr		
			Dep Ovr Comment		
			Misc Imp Ovr		
			Misc Imp Ovr Comment		
			Cost to Cure Ovr		
			Cost to Cure Ovr Comment		

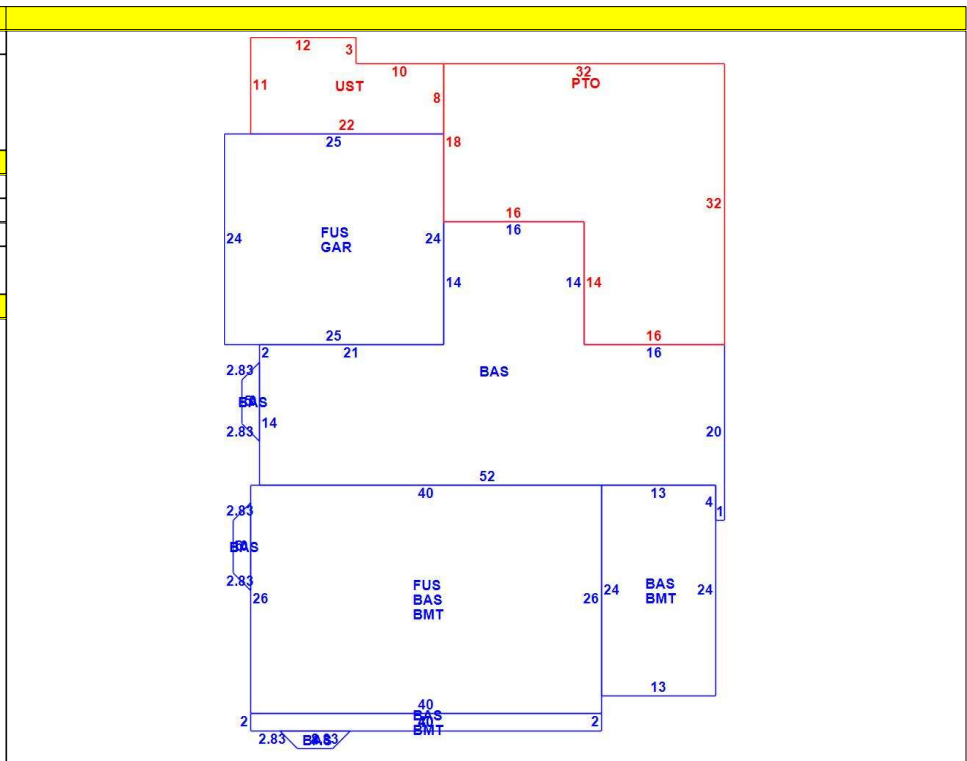

OB - OUTBUILDING & YARD ITEMS(L) / XF - BUILDING EXTRA FEATURES(B)										
Code	Description	L/B	Units	Unit Price	Yr Blt	Cond. Cd	% Gd	Grade	Grade Adj.	Appr. Value
FPL2	Fireplace 1.5 s	B	2	6000.00	1997		81		0.00	9,700
SPL3	Pool Gunite	L	760	75.00	1985		22	C	1.00	12,700
BFA1	Bsmt Fin-Goo	B	770	32.56	1997		81		0.00	20,300
PAT1	Patio- Average	L	800	5.89	1997		78		0.00	3,400
GAR	Attached Gara	B	600	40.00	1997		81		0.00	17,000
UST	Utility Storage	B	212	17.11	1997		81		0.00	2,000
BMT	Basement-Unfi	B	1,432	26.01	1997		81		0.00	27,800
SPDC	POOL DECK	L	800	5.61	1997		73		0.00	3,300
PAT1	Patio- Average	L	980	5.89	2020		96		0.00	5,000
SPDC	POOL DECK	L	980	5.61	2020		96		0.00	5,300

BUILDING SUB-AREA SUMMARY SECTION							
Code	Description	Living Area	Floor Area	Eff Area	Unit Cost	Undeprec Value	
BAS	First Floor	2,550	2,550	2,550	256.91	655,108	
BMT	Basement Area	0	1,432	0	0.00	0	
FUS	Upper Story	1,640	1,640	1,640	256.91	421,324	
GAR	Attached Garage	0	600	0	0.00	0	
PTO	Patio	0	800	0	0.00	0	
UST	Utility Enclosure	0	212	0	0.00	0	
Ttl Gross Liv / Lease Area		4,190	7,234	4,190		1,076,432	



CURRENT OWNER		TOPO	UTILITIES	STRT / ROAD	LOCATION	CURRENT ASSESSMENT				
EDWARDS, MARK TR BONITA MARIE LESLIE TRUST 226 MAIN STREET						Description	Code	Assessed	Assessed	801 FY2025 BARNSTABLE, MA
CENTERVILLE MA 02632					3	RESIDNTL	1010	1,016,700	1,016,700	
SUPPLEMENTAL DATA						RES LAND	1010	180,700	180,700	VISION
Alt Prcl ID Split Zonin BID Parcel ResExpt Q #DL 1 LOT 11A; PARCELA #DL 2 GIS ID F_971875_2700994				Plan Ref. 315/22; 434/68 Land Ct# #SR Life Estate PP STATU Assoc Pid#		Total		1,197,400	1,197,400	

RECORD OF OWNERSHIP		BK-VOL/PAGE	SALE DATE	Q/U	V/I	SALE PRIC	VC	PREVIOUS ASSESSMENTS (HISTORY)					
								Year	Code	Assessed	Year	Code	Assessed
								2025	1010	1,016,700	2024	1010	964,600
									1010	180,700		1010	180,700
								Total		1,197,400	Total		1,145,300
								Total			Total		1,040,800

EXEMPTIONS			OTHER ASSESSMENTS					APPRAISED VALUE SUMMARY					
Year	Code	Description	Amount	Code	Description	Number	Amount	Comm Int	This signature acknowledges a visit by a Data Collector or Assessor				
									APPRAISED VALUE SUMMARY				
Total									Appraised Bldg. Value (Card) 871,900				
									Appraised Xf (B) Value (Bldg) 76,800				
									Appraised Ob (B) Value (Bldg) 68,000				
									Appraised Land Value (Bldg) 180,700				
									Special Land Value 0				
									Total Appraised Parcel Value 1,197,400				
									Valuation Method C				
									Total Appraised Parcel Value 1,197,400				

BUILDING PERMIT RECORD										VISIT / CHANGE HISTORY					
Permit Id	Issue Date	Type	Description	Amount	Insp Date	% Comp	Date Comp	Comments		Date	Id	Type	Is	Cd	Purpost/Result

LAND LINE VALUATION SECTION																
B	Use Code	Description	Zone	LA	Land Units	Unit Price	Size Adj	AC Disc	Site Index	Cond.	Nbhd.	Nbhd. Adj	Notes	Location Adjustmen	Adj Unit P	Land Value
Total Card Land Units					Parcel Total Land Area					Total Land Value						

