

| CURRENT OWNER                                                                                                 |  | TOPO |       | UTILITIES |        | STRT / ROAD                                                                  |       | LOCATION |  | CURRENT ASSESSMENT        |      |          |          |
|---------------------------------------------------------------------------------------------------------------|--|------|-------|-----------|--------|------------------------------------------------------------------------------|-------|----------|--|---------------------------|------|----------|----------|
| LEWIS, ELIZABETH M<br><br>2085 MAIN ST./RTE 6A<br><br>WEST BARNSTA MA 02668                                   |  | 1    | Level | 4         | Gas    | 1                                                                            | Paved |          |  | Description               | Code | Assessed | Assessed |
|                                                                                                               |  |      |       | 5         | Well   |                                                                              |       |          |  | RESIDENTL                 | 1010 | 860,700  | 860,700  |
|                                                                                                               |  |      |       | 6         | Septic |                                                                              |       | 1        |  | RES LAND                  | 1010 | 220,200  | 220,200  |
| <b>SUPPLEMENTAL DATA</b>                                                                                      |  |      |       |           |        |                                                                              |       |          |  |                           |      |          |          |
| Alt Prcl ID<br>Split Zonin<br>BID Parcel<br>ResExpt Q YES:<br>#DL 1 LOT 1<br>#DL 2<br>GIS ID F_973335_2716636 |  |      |       |           |        | Plan Ref. 382/87<br>Land Ct#<br>#SR<br>Life Estate<br>PP STATU<br>Assoc Pid# |       |          |  | Total 1,080,900 1,080,900 |      |          |          |

801  
FY2025  
BARNSTABLE, MA

**VISION**

| RECORD OF OWNERSHIP              |  | BK-VOL/PAGE |      | SALE DATE  |  | Q/U |   | V/I |  | SALE PRIC |    | VC        |      | PREVIOUS ASSESSMENTS (HISTORY) |      |           |          |       |      |          |  |
|----------------------------------|--|-------------|------|------------|--|-----|---|-----|--|-----------|----|-----------|------|--------------------------------|------|-----------|----------|-------|------|----------|--|
| LEWIS, ELIZABETH M               |  | 24054       | 0125 | 09-25-2009 |  | U   | I |     |  | 555,000   | 1A | Year      | Code | Assessed                       | Year | Code      | Assessed | Year  | Code | Assessed |  |
| LEWIS, MARJORIE C (HANDY) ESTATE |  | 24054       | 0121 | 09-25-2009 |  | U   | I |     |  | 0         | 1  | 2025      | 1010 | 860,700                        | 2024 | 1010      | 814,800  | 2023  | 1010 | 724,100  |  |
| LEWIS, MARJORIE C                |  | 0776        | 0201 | 02-09-1951 |  | U   |   |     |  | 0         |    |           | 1010 | 220,200                        |      |           | 220,200  |       | 1010 | 219,300  |  |
| Total                            |  |             |      |            |  |     |   |     |  |           |    | 1,080,900 |      | Total                          |      | 1,035,000 |          | Total |      | 943,400  |  |

| EXEMPTIONS |      |                       |        | OTHER ASSESSMENTS |             |        |        | This signature acknowledges a visit by a Data Collector or Assessor |  |  |  |  |  |  |  |  |  |  |  |
|------------|------|-----------------------|--------|-------------------|-------------|--------|--------|---------------------------------------------------------------------|--|--|--|--|--|--|--|--|--|--|--|
| Year       | Code | Description           | Amount | Code              | Description | Number | Amount |                                                                     |  |  |  |  |  |  |  |  |  |  |  |
| 2011       | 5C   | RESIDENTIAL EXEMPTION | 0.00   |                   |             |        |        |                                                                     |  |  |  |  |  |  |  |  |  |  |  |
| Total      |      |                       | 0.00   |                   |             |        |        |                                                                     |  |  |  |  |  |  |  |  |  |  |  |

| ASSESSING NEIGHBORHOOD |           |  |   | APPRAISED VALUE SUMMARY |  |       |  |                               |           |
|------------------------|-----------|--|---|-------------------------|--|-------|--|-------------------------------|-----------|
| Nbhd                   | Nbhd Name |  | B | Tracing                 |  | Batch |  | Appraised Bldg. Value (Card)  | 763,600   |
| 0106                   |           |  |   |                         |  | BARNs |  | Appraised Xf (B) Value (Bldg) | 78,700    |
| <b>NOTES</b>           |           |  |   |                         |  |       |  | Appraised Ob (B) Value (Bldg) | 18,400    |
|                        |           |  |   |                         |  |       |  | Appraised Land Value (Bldg)   | 220,200   |
|                        |           |  |   |                         |  |       |  | Special Land Value            | 0         |
|                        |           |  |   |                         |  |       |  | Total Appraised Parcel Value  | 1,080,900 |
|                        |           |  |   |                         |  |       |  | Valuation Method              | C         |
|                        |           |  |   |                         |  |       |  | Total Appraised Parcel Value  | 1,080,900 |

| BUILDING PERMIT RECORD |            |      |              |         |            |        |            |                              | VISIT / CHANGE HISTORY |    |      |    |    |                       |
|------------------------|------------|------|--------------|---------|------------|--------|------------|------------------------------|------------------------|----|------|----|----|-----------------------|
| Permit Id              | Issue Date | Type | Description  | Amount  | Insp Date  | % Comp | Date Comp  | Comments                     | Date                   | Id | Type | Is | Cd | Purpost/Result        |
| BLDR-20-36             | 12-10-2020 | 804  | Addn Alt-Res | 79,000  | 05-11-2021 | 100    | 06-30-2021 | Remove existing deck and out | 05-11-2021             | SR | 02   |    | 02 | Bldg Permit Completed |
| 201308145              | 11-06-2013 | GN   | Generator    | 0       | 11-12-2013 | 100    | 06-30-2014 | GENERATOR                    | 05-14-2020             | DM |      |    | FR | Field Review          |
| 201302585              | 04-29-2013 | RE   | Remodel      | 30,000  | 11-12-2013 | 100    | 06-30-2014 | ADD SKYLIGHT-REMODO BTH      | 04-03-2015             | JR | 03   |    | 03 | Cycl Insp Comp        |
| 201105280              | 09-29-2011 | IN   | Insulation   | 2,356   | 06-30-2012 | 100    | 06-30-2012 | AIR SEAL-INSULATE            | 02-05-2014             | MW | 02   |    | 02 | Bldg Permit Completed |
| 201001700              | 04-22-2010 | AD   | Addition     | 400,000 | 03-09-2011 | 100    | 06-30-2011 | MBDRM & KIT EXPANSION -      | 06-14-2011             | RB | 03   |    | 02 | Bldg Permit Completed |
|                        |            |      |              |         |            |        |            |                              | 07-12-2010             | MA | 22   |    | 22 | Change of Address     |
|                        |            |      |              |         |            |        |            |                              | 12-30-2009             | TP | 03   |    | 16 | In Office Review      |

| LAND LINE VALUATION SECTION |          |                |      |    |            |               |                        |         |            |       |       |           |                  |                    |            |            |
|-----------------------------|----------|----------------|------|----|------------|---------------|------------------------|---------|------------|-------|-------|-----------|------------------|--------------------|------------|------------|
| B                           | Use Code | Description    | Zone | LA | Land Units | Unit Price    | Size Adj               | AC Disc | Site Index | Cond. | Nbhd. | Nbhd. Adj | Notes            | Location Adjustmen | Adj Unit P | Land Value |
| 1                           | 1010     | Single Fam M-0 | RF   | 1  | 1.000      | AC 176,344.00 | 1.00000                | 1.0000  | 5          | 1.00  | 0106  | 1.150     |                  | 1.0000             | 202,795.6  | 202,800    |
| 1                           | 1010     | Single Fam M-0 | RF   | 1  | 1.060      | AC 14,250.00  | 1.00000                | 1.0000  | 0          | 1.00  | 0106  | 1.150     |                  | 1.0000             | 16,387.5   | 17,400     |
| Total Card Land Units       |          |                |      |    | 2.06       | AC            | Parcel Total Land Area |         |            |       |       | 2.06      | Total Land Value |                    |            | 220,200    |

| CONSTRUCTION DETAIL |      |                | CONSTRUCTION DETAIL (CONTINUED) |      |                     |
|---------------------|------|----------------|---------------------------------|------|---------------------|
| Element             | Cd   | Description    | Element                         | Cd   | Description         |
| Style               | 04   | Cape Cod       |                                 |      |                     |
| Model               | 01   | Residential    |                                 |      |                     |
| Grade:              | C+   | Average Plus   |                                 |      |                     |
| Stories             | 1.75 | 1 3/4 Stories  |                                 |      |                     |
| Exterior Wall 1     | 14   | Wood Shingle   |                                 |      |                     |
| Exterior Wall 2     |      |                |                                 |      |                     |
| RooF Structure      | 03   | Gable/Hip      |                                 |      |                     |
| RooF Cover          | 03   | Asph/F Gls/Cmp |                                 |      |                     |
| Interior Wall 1     | 05   | Drywall        |                                 |      |                     |
| Interior Wall 2     |      |                |                                 |      |                     |
| Interior Floor 1    | 09   | Pine/Soft Wood |                                 |      |                     |
| Interior Floor 2    |      |                |                                 |      |                     |
| Heat Fuel           | 03   | Gas            |                                 |      |                     |
| Heat Type           | 05   | Hot Water      |                                 |      |                     |
| AC Type             | 03   | Central        |                                 |      |                     |
| Bedrooms            | 03   | 3 Bedrooms     |                                 |      |                     |
| Full Baths          | 3    |                |                                 |      |                     |
| Half Baths          | 1    |                |                                 |      |                     |
| Extra Fixtures      |      |                |                                 |      |                     |
| Total Rooms         | 8    |                |                                 |      |                     |
| Bath Style          |      |                |                                 |      |                     |
| Kitchen Style       |      |                |                                 |      |                     |
| Occupancy           |      |                |                                 |      |                     |
| Sewer Occupan       |      |                |                                 |      |                     |
| Accessory Apt       |      |                |                                 |      |                     |
| Foundation Alt      | 01   | Poured Conc.   |                                 |      |                     |
| Rms Prts            |      |                |                                 |      |                     |
| Bath Split          | 31   | 3 Full-1 Half  |                                 |      |                     |
|                     |      |                | <b>CONDO DATA</b>               |      |                     |
|                     |      |                | Parcel Id                       | C    | Owne 0.0            |
|                     |      |                | Adjust Type                     | Code | Description Factor% |
|                     |      |                | Condo Flr                       |      |                     |
|                     |      |                | Condo Unit                      |      |                     |
|                     |      |                | <b>COST / MARKET VALUATION</b>  |      |                     |
|                     |      |                | Building Value New              |      | 843,088             |
|                     |      |                | Year Built                      |      | 1984                |
|                     |      |                | Effective Year Built            |      | 2007                |
|                     |      |                | Depreciation Code               |      | G                   |
|                     |      |                | Remodel Rating                  |      |                     |
|                     |      |                | Year Remodeled                  |      |                     |
|                     |      |                | Depreciation %                  |      | 13                  |
|                     |      |                | Functional Obsol                |      | 0                   |
|                     |      |                | External Obsol                  |      | 0                   |
|                     |      |                | Trend Factor                    |      | 1                   |
|                     |      |                | Condition                       |      |                     |
|                     |      |                | Condition %                     |      |                     |
|                     |      |                | Percent Good                    |      | 87                  |
|                     |      |                | RCNLD                           |      | 763,600             |
|                     |      |                | Dep % Ovr                       |      |                     |
|                     |      |                | Dep Ovr Comment                 |      |                     |
|                     |      |                | Misc Imp Ovr                    |      |                     |
|                     |      |                | Misc Imp Ovr Comment            |      |                     |
|                     |      |                | Cost to Cure Ovr                |      |                     |
|                     |      |                | Cost to Cure Ovr Comment        |      |                     |

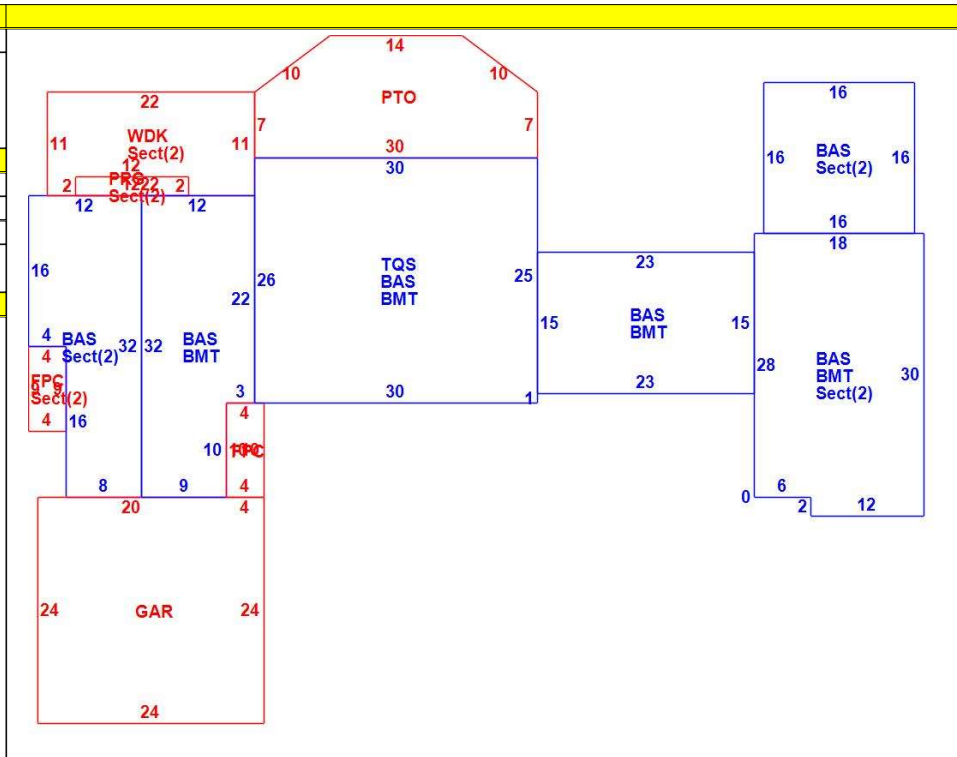

| OB - OUTBUILDING & YARD ITEMS(L) / XF - BUILDING EXTRA FEATURES(B) |                 |     |       |            |        |          |      |       |            |             |
|--------------------------------------------------------------------|-----------------|-----|-------|------------|--------|----------|------|-------|------------|-------------|
| Code                                                               | Description     | L/B | Units | Unit Price | Yr Blt | Cond. Cd | % Gd | Grade | Grade Adj. | Appr. Value |
| FPL2                                                               | Fireplace 1.5 s | B   | 1     | 6000.00    | 2005   |          | 87   |       | 0.00       | 5,200       |
| FPO                                                                | Ext FP Openin   | B   | 1     | 2000.00    | 2005   |          | 87   |       | 0.00       | 1,700       |
| PATF                                                               | Flagstone Pav   | L   | 342   | 30.00      | 2009   |          | 90   |       | 0.00       | 9,200       |
| FOPC                                                               | Open Prch-roo   | B   | 40    | 55.00      | 2005   |          | 87   |       | 0.00       | 2,100       |
| GAR                                                                | Attached Gara   | B   | 576   | 40.00      | 2005   |          | 87   |       | 0.00       | 17,800      |
| BMT                                                                | Basement-Unfi   | B   | 1,479 | 26.01      | 2005   |          | 87   |       | 0.00       | 30,500      |
| GEN                                                                | Emergency Ge    | L   | 1     | 5550.00    | 2013   |          | 88   |       | 0.00       | 4,900       |
| FPLG                                                               | Gas Fireplace-  | B   | 1     | 2500.00    | 2005   |          | 87   |       | 0.00       | 2,200       |

| BUILDING SUB-AREA SUMMARY SECTION |                        |             |            |          |           |                |
|-----------------------------------|------------------------|-------------|------------|----------|-----------|----------------|
| Code                              | Description            | Living Area | Floor Area | Eff Area | Unit Cost | Undeprec Value |
| BAS                               | First Floor            | 1,479       | 1,479      | 1,479    | 272.84    | 403,536        |
| BMT                               | Basement Area          | 0           | 1,479      | 0        | 0.00      | 0              |
| FPC                               | Open Porch Conc. Floor | 0           | 40         | 0        | 0.00      | 0              |
| GAR                               | Attached Garage        | 0           | 576        | 0        | 0.00      | 0              |
| PTO                               | Patio                  | 0           | 342        | 0        | 0.00      | 0              |
| TQS                               | Three Quarter Story    | 507         | 780        | 507      | 177.35    | 138,332        |
| Ttl Gross Liv / Lease Area        |                        | 1,986       | 4,696      | 1,986    |           | 541,868        |



| CURRENT OWNER                                                                                                 |  | TOPO |       | UTILITIES |        | STRT / ROAD                                                                  |       | LOCATION |  | CURRENT ASSESSMENT        |      |          |          |
|---------------------------------------------------------------------------------------------------------------|--|------|-------|-----------|--------|------------------------------------------------------------------------------|-------|----------|--|---------------------------|------|----------|----------|
| LEWIS, ELIZABETH M<br><br>2085 MAIN ST./RTE 6A<br><br>WEST BARNSTA MA 02668                                   |  | 1    | Level | 4         | Gas    | 1                                                                            | Paved |          |  | Description               | Code | Assessed | Assessed |
|                                                                                                               |  |      |       | 5         | Well   |                                                                              |       |          |  | RESIDENTL                 | 1010 | 860,700  | 860,700  |
|                                                                                                               |  |      |       | 6         | Septic |                                                                              |       | 1        |  | RES LAND                  | 1010 | 220,200  | 220,200  |
| <b>SUPPLEMENTAL DATA</b>                                                                                      |  |      |       |           |        |                                                                              |       |          |  |                           |      |          |          |
| Alt Prcl ID<br>Split Zonin<br>BID Parcel<br>ResExpt Q YES:<br>#DL 1 LOT 1<br>#DL 2<br>GIS ID F_973335_2716636 |  |      |       |           |        | Plan Ref. 382/87<br>Land Ct#<br>#SR<br>Life Estate<br>PP STATU<br>Assoc Pid# |       |          |  | Total 1,080,900 1,080,900 |      |          |          |

801  
FY2025  
BARNSTABLE, MA

**VISION**

| RECORD OF OWNERSHIP              |  | BK-VOL/PAGE |      | SALE DATE  |  | Q/U |   | V/I |  | SALE PRIC |    | VC        |      | PREVIOUS ASSESSMENTS (HISTORY) |      |           |          |       |      |          |  |
|----------------------------------|--|-------------|------|------------|--|-----|---|-----|--|-----------|----|-----------|------|--------------------------------|------|-----------|----------|-------|------|----------|--|
| LEWIS, ELIZABETH M               |  | 24054       | 0125 | 09-25-2009 |  | U   | I |     |  | 555,000   | 1A | Year      | Code | Assessed                       | Year | Code      | Assessed | Year  | Code | Assessed |  |
| LEWIS, MARJORIE C (HANDY) ESTATE |  | 24054       | 0121 | 09-25-2009 |  | U   | I |     |  | 0         | 1  | 2025      | 1010 | 860,700                        | 2024 | 1010      | 814,800  | 2023  | 1010 | 724,100  |  |
| LEWIS, MARJORIE C                |  | 0776        | 0201 | 02-09-1951 |  | U   |   |     |  | 0         |    |           | 1010 | 220,200                        |      |           | 220,200  |       |      | 219,300  |  |
| Total                            |  |             |      |            |  |     |   |     |  |           |    | 1,080,900 |      | Total                          |      | 1,035,000 |          | Total |      | 943,400  |  |

| EXEMPTIONS |      |                       |        | OTHER ASSESSMENTS |             |        |        | This signature acknowledges a visit by a Data Collector or Assessor |  |  |  |  |  |  |  |  |  |  |  |
|------------|------|-----------------------|--------|-------------------|-------------|--------|--------|---------------------------------------------------------------------|--|--|--|--|--|--|--|--|--|--|--|
| Year       | Code | Description           | Amount | Code              | Description | Number | Amount |                                                                     |  |  |  |  |  |  |  |  |  |  |  |
| 2011       | 5C   | RESIDENTIAL EXEMPTION | 0.00   |                   |             |        |        |                                                                     |  |  |  |  |  |  |  |  |  |  |  |
| Total      |      |                       | 0.00   |                   |             |        |        |                                                                     |  |  |  |  |  |  |  |  |  |  |  |

| ASSESSING NEIGHBORHOOD |           |  |   | APPRAISED VALUE SUMMARY |  |       |  |                               |           |
|------------------------|-----------|--|---|-------------------------|--|-------|--|-------------------------------|-----------|
| Nbhd                   | Nbhd Name |  | B | Tracing                 |  | Batch |  | Appraised Bldg. Value (Card)  | 763,600   |
| 0106                   |           |  |   |                         |  | BARNs |  | Appraised Xf (B) Value (Bldg) | 78,700    |
| <b>NOTES</b>           |           |  |   |                         |  |       |  | Appraised Ob (B) Value (Bldg) | 18,400    |
|                        |           |  |   |                         |  |       |  | Appraised Land Value (Bldg)   | 220,200   |
|                        |           |  |   |                         |  |       |  | Special Land Value            | 0         |
|                        |           |  |   |                         |  |       |  | Total Appraised Parcel Value  | 1,080,900 |
|                        |           |  |   |                         |  |       |  | Valuation Method              | C         |
|                        |           |  |   |                         |  |       |  | Total Appraised Parcel Value  | 1,080,900 |

| BUILDING PERMIT RECORD |            |      |              |         |            |        |            |                              | VISIT / CHANGE HISTORY |    |      |    |    |                       |
|------------------------|------------|------|--------------|---------|------------|--------|------------|------------------------------|------------------------|----|------|----|----|-----------------------|
| Permit Id              | Issue Date | Type | Description  | Amount  | Insp Date  | % Comp | Date Comp  | Comments                     | Date                   | Id | Type | Is | Cd | Purpost/Result        |
| BLDR-20-36             | 12-10-2020 | 804  | Addn Alt-Res | 79,000  | 05-11-2021 | 100    | 06-30-2021 | Remove existing deck and out | 05-11-2021             | SR | 02   |    | 02 | Bldg Permit Completed |
| 201308145              | 11-06-2013 | GN   | Generator    | 0       | 11-12-2013 | 100    | 06-30-2014 | GENERATOR                    | 05-14-2020             | DM |      |    | FR | Field Review          |
| 201302585              | 04-29-2013 | RE   | Remodel      | 30,000  | 11-12-2013 | 100    | 06-30-2014 | ADD SKYLIGHT-REMODO BTH      | 04-03-2015             | JR | 03   |    | 03 | Cycl Insp Comp        |
| 201105280              | 09-29-2011 | IN   | Insulation   | 2,356   | 06-30-2012 | 100    | 06-30-2012 | AIR SEAL-INSULATE            | 02-05-2014             | MW | 02   |    | 02 | Bldg Permit Completed |
| 201001700              | 04-22-2010 | AD   | Addition     | 400,000 | 03-09-2011 | 100    | 06-30-2011 | MBDRM & KIT EXPANSION -      | 06-14-2011             | RB | 03   |    | 02 | Bldg Permit Completed |
|                        |            |      |              |         |            |        |            |                              | 07-12-2010             | MA | 22   |    | 22 | Change of Address     |
|                        |            |      |              |         |            |        |            |                              | 12-30-2009             | TP | 03   |    | 16 | In Office Review      |

| LAND LINE VALUATION SECTION |          |                |      |    |            |               |                        |         |            |       |       |           |                  |                    |            |            |         |
|-----------------------------|----------|----------------|------|----|------------|---------------|------------------------|---------|------------|-------|-------|-----------|------------------|--------------------|------------|------------|---------|
| B                           | Use Code | Description    | Zone | LA | Land Units | Unit Price    | Size Adj               | AC Disc | Site Index | Cond. | Nbhd. | Nbhd. Adj | Notes            | Location Adjustmen | Adj Unit P | Land Value |         |
| 1                           | 1010     | Single Fam M-0 | RF   | 1  | 1.000      | AC 176,344.00 | 1.00000                | 1.0000  | 5          | 1.00  | 0106  | 1.150     |                  | 1.0000             | 202,795.6  | 202,800    |         |
| 1                           | 1010     | Single Fam M-0 | RF   | 1  | 1.060      | AC 14,250.00  | 1.00000                | 1.0000  | 0          | 1.00  | 0106  | 1.150     |                  | 1.0000             | 16,387.5   | 17,400     |         |
| Total Card Land Units       |          |                |      |    | 2.06       | AC            | Parcel Total Land Area |         |            |       |       | 2.06      | Total Land Value |                    |            |            | 220,200 |



| CONSTRUCTION DETAIL |     |                | CONSTRUCTION DETAIL (CONTINUED)      |    |             |
|---------------------|-----|----------------|--------------------------------------|----|-------------|
| Element             | Cd  | Description    | Element                              | Cd | Description |
| Style               | 04  | Cape Cod       |                                      |    |             |
| Model               | 01  | Residential    |                                      |    |             |
| Grade:              | C+  | Average Plus   |                                      |    |             |
| Stories             | 1.5 | 1 1/2 Stories  |                                      |    |             |
| Exterior Wall 1     | 14  | Wood Shingle   |                                      |    |             |
| Exterior Wall 2     | 11  | Clapboard      |                                      |    |             |
| Roof Structure      | 03  | Gable/Hip      |                                      |    |             |
| Roof Cover          | 03  | Asph/F Gls/Cmp |                                      |    |             |
| Interior Wall 1     | 05  | Drywall        |                                      |    |             |
| Interior Wall 2     |     |                |                                      |    |             |
| Interior Floor 1    | 09  | Pine/Soft Wood |                                      |    |             |
| Interior Floor 2    |     |                |                                      |    |             |
| Heat Fuel           | 03  | Gas            |                                      |    |             |
| Heat Type           | 05  | Hot Water      |                                      |    |             |
| AC Type             | 03  | Central        |                                      |    |             |
| Bedrooms            | 03  | 3 Bedrooms     |                                      |    |             |
| Full Baths          | 3   |                |                                      |    |             |
| Half Baths          | 1   |                |                                      |    |             |
| Extra Fixtures      |     |                |                                      |    |             |
| Total Rooms         | 8   |                |                                      |    |             |
| Bath Style          |     |                |                                      |    |             |
| Kitchen Style       |     |                |                                      |    |             |
| Occupancy           |     |                |                                      |    |             |
| Sewer Occupan       |     |                |                                      |    |             |
| Accessory Apt       |     |                |                                      |    |             |
| Foundation Alt      | 01  | Poured Conc.   |                                      |    |             |
| Rms Prts            |     |                |                                      |    |             |
| Bath Split          | 31  | 3 Full-1 Half  |                                      |    |             |
|                     |     |                | <b>CONDO DATA</b>                    |    |             |
|                     |     |                | Parcel Id                            | C  | Ownr 0.0    |
|                     |     |                | Adjust Type Code Description Factor% |    |             |
|                     |     |                | Condo Flr Condo Unit                 |    |             |
|                     |     |                | <b>COST / MARKET VALUATION</b>       |    |             |
|                     |     |                | Building Value New                   |    | 843,088     |
|                     |     |                | Year Built                           |    | 2010        |
|                     |     |                | Effective Year Built                 |    | 2020        |
|                     |     |                | Depreciation Code                    |    | G           |
|                     |     |                | Remodel Rating                       |    |             |
|                     |     |                | Year Remodeled                       |    |             |
|                     |     |                | Depreciation %                       |    | 3           |
|                     |     |                | Functional Obsol                     |    | 0           |
|                     |     |                | External Obsol                       |    | 0           |
|                     |     |                | Trend Factor                         |    | 1           |
|                     |     |                | Condition                            |    |             |
|                     |     |                | Condition %                          |    |             |
|                     |     |                | Percent Good                         |    | 97          |
|                     |     |                | RCNLD                                |    | 763,600     |
|                     |     |                | Dep % Ovr                            |    |             |
|                     |     |                | Dep Ovr Comment                      |    |             |
|                     |     |                | Misc Imp Ovr                         |    |             |
|                     |     |                | Misc Imp Ovr Comment                 |    |             |
|                     |     |                | Cost to Cure Ovr                     |    |             |
|                     |     |                | Cost to Cure Ovr Comment             |    |             |

| OB - OUTBUILDING & YARD ITEMS(L) / XF - BUILDING EXTRA FEATURES(B) |               |     |       |            |        |          |      |       |            |             |
|--------------------------------------------------------------------|---------------|-----|-------|------------|--------|----------|------|-------|------------|-------------|
| Code                                                               | Description   | L/B | Units | Unit Price | Yr Blt | Cond. Cd | % Gd | Grade | Grade Adj. | Appr. Value |
| WDC                                                                | Wood Deck w/  | L   | 242   | 18.00      | 2011   |          | 84   |       | 0.00       | 4,000       |
| FOPC                                                               | Open Prch-roo | B   | 36    | 55.00      | 2018   |          | 97   |       | 0.00       | 2,200       |
| BMT                                                                | Basement-Unfi | B   | 528   | 26.01      | 2018   |          | 97   |       | 0.00       | 17,000      |
| PRG1                                                               | Pergola-Avg   | L   | 24    | 18.00      | 2013   |          | 78   | C     | 1.00       | 300         |

| BUILDING SUB-AREA SUMMARY SECTION |                        |             |            |          |           |                |
|-----------------------------------|------------------------|-------------|------------|----------|-----------|----------------|
| Code                              | Description            | Living Area | Floor Area | Eff Area | Unit Cost | Undeprec Value |
| BAS                               | First Floor            | 1,104       | 1,104      | 1,104    | 272.84    | 301,220        |
| BMT                               | Basement Area          | 0           | 528        | 0        | 0.00      | 0              |
| FPC                               | Open Porch Conc. Floor | 0           | 36         | 0        | 0.00      | 0              |
| PRG                               | Pergola                | 0           | 24         | 0        | 0.00      | 0              |
| WDC                               | Wood Deck              | 0           | 242        | 0        | 0.00      | 0              |
| Ttl Gross Liv / Lease Area        |                        | 1,104       | 1,934      | 1,104    |           | 301,220        |

