

CONSTRUCTION DETAIL			CONSTRUCTION DETAIL (CONTINUED)		
Element	Cd	Description	Element	Cd	Description
Style	31	Branch Bank			
Model	94	Commercial			
Grade	C	Average			
Stories	1.5				
Occupancy	1.00				
Exterior Wall 1	19	Brick Veneer			
Exterior Wall 2	25	Vinyl Siding			
Roof Structure	03	Gable/Hip			
Roof Cover	03	Asph/F Gls/Cmp			
Interior Wall 1	05	Drywall			
Interior Wall 2					
Interior Floor 1	14	Carpet			
Interior Floor 2	11	Ceram Clay Til			
Heating Fuel	03	Gas			
Heating Type	04	Hot Air			
AC Type	03	Central			
Size Adj Tbl	3410	BANK BLDG			
Total Rooms					
Bedrooms	00				
Full Bathrooms	1				
Bath Split	01	0 Full-1 Half			
Rms/Partitions	02	AVERAGE			
Heat/AC	01	HEAT/AC PKGS			
Frame Type	02	WOOD FRAME			
Baths/Plumbing	02	AVERAGE			
Ceiling/Wall	06	CEIL & WALLS			
Common Wall	00	0%			
Wall Height	10.00				
1st Floor Use:	3410				
Sewer Occupan					

MIXED USE		
Code	Description	Percentage
3410	BANK BLDG	100
		0
		0

COST / MARKET VALUATION	
RCN	1,277,256
Year Built	1985
Effective Year Built	1994
Depreciation Code	A
Remodel Rating	
Year Remodeled	
Depreciation %	23
Functional Obsol	0
External Obsol	0
Trend Factor	1
Condition	
Condition %	
Percent Good	77
RCNLD	983,500
Dep % Ovr	
Dep Ovr Comment	
Misc Imp Ovr	
Misc Imp Ovr Comment	
Cost to Cure Ovr	
Cost to Cure Ovr Comment	

OB - OUTBUILDING & YARD ITEMS(L) / XF - BUILDING EXTRA FEATURES(B)										
Code	Description	L/B	Units	Unit Price	Yr Bilt	Cond. Cd	% Good	Grade	Grade Adj	Appr. Value
PAV1	PAVING-ASPH	L	40,000	3.00	1990		42		0.00	50,400
ATM1	Automatic Teller	L	1	50500.00	1997		56		0.00	28,300
DUW	W/PNEU TUBE	B	2	27489.00	1991		77		0.00	42,300
VLT2	VAULT-GOOD	B	200	263.85	1991		77		0.00	40,600
VLTD	Vault Door - Ba	L	1	34484.00	1998		79		0.00	27,200
NDP	NITE DEPOSIT	B	1	21906.00	1991		77		0.00	16,900
FGPL	Flagpole-25'	L	2	2229.00	2017		96		0.00	4,300
SGN2	DOUBLE SIDE	L	25	39.53	2017		96		0.00	900
SGNP	SIGN POST 6"	L	16	10.66	2017		96		0.00	200
PKBR	Parking Bumper	L	10	52.17	2017		96		0.00	500

BUILDING SUB-AREA SUMMARY SECTION							
Code	Description	Living Area	Floor Area	Eff Area	Unit Cost	Undeprec Value	
BAS	First Floor	3,076	3,076	3,076	233.76	719,041	
CAN	Canopy	0	440	44	23.38	10,285	
FBM	Fin Bsmnt	1,538	3,076	1,230	93.47	287,523	
FPC	Open Porch Conc. Floor	0	178	27	35.46	6,311	
UHS	Half Story, Unfinished	0	2,416	1,087	105.17	254,095	
Ttl Gross Liv / Lease Area		4,614	9,186	5,464		1,277,255	

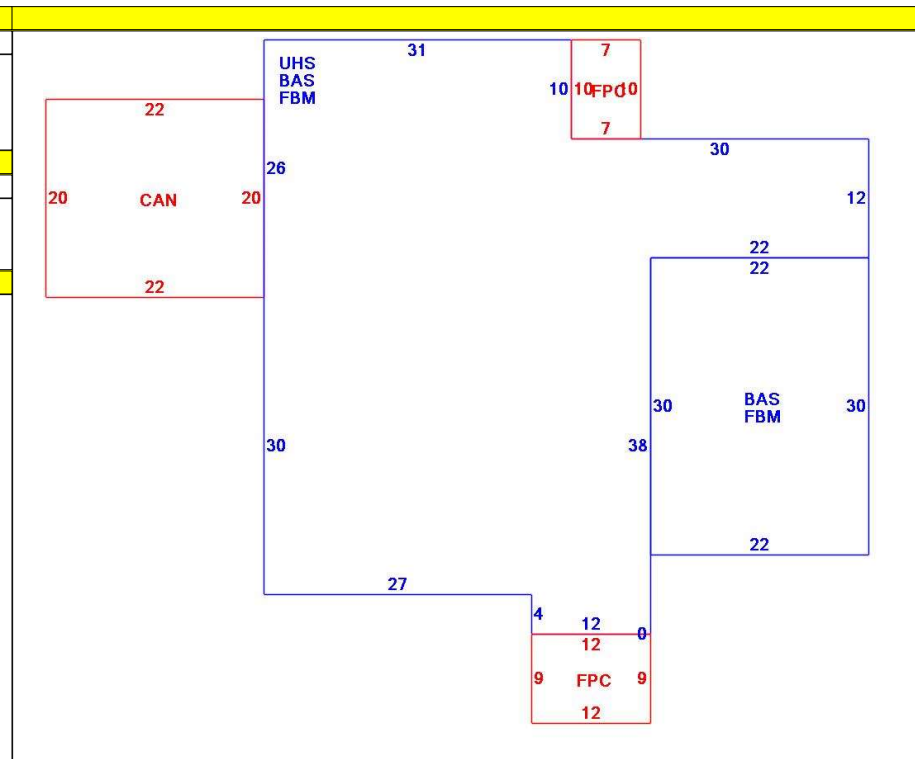

CONSTRUCTION DETAIL					CONSTRUCTION DETAIL (CONTINUED)					
Element	Cd	Description			Element	Cd	Description			
Style	31	Branch Bank								
Model	94	Commercial								
Grade	C	Average								
Stories	1.5									
Occupancy	1.00									
Exterior Wall 1	19	Brick Veneer								
Exterior Wall 2	25	Vinyl Siding								
Roof Structure	03	Gable/Hip								
Roof Cover	03	Asph/F Gls/Cmp								
Interior Wall 1	05	Drywall								
Interior Wall 2										
Interior Floor 1	14	Carpet								
Interior Floor 2	11	Ceram Clay Til								
Heating Fuel	03	Gas								
Heating Type	04	Hot Air								
AC Type	03	Central								
Size Adj Tbl	3410	BANK BLDG								
Total Rooms										
Bedrooms	00									
Full Bathrooms	1									
Bath Split	01	0 Full-1 Half								
Rms/Partitions	02	AVERAGE								
Heat/AC	01	HEAT/AC PKGS								
Frame Type	02	WOOD FRAME								
Baths/Plumbing	02	AVERAGE								
Ceiling/Wall	06	CEIL & WALLS								
Common Wall	00	0%								
Wall Height	10.00									
1st Floor Use:	3410									
Sewer Occupan										
OB - OUTBUILDING & YARD ITEMS(L) / XF - BUILDING EXTRA FEATURES(B)										
Code	Description	L/B	Units	Unit Price	Yr Blt	Cond. Cd	% Good	Grade	Grade Adj	Appr. Value
LTLS	Walkwy Lights	L	5	107.56	2017		96		0.00	500
SGN2	DOUBLE SIDE	L	8	39.53	2017		96		0.00	300
FNC2	Fence-6' Wd	L	64	27.85	2017		96		0.00	1,700
FNG1	Gate 4'x3'w	L	1	301.53	2017		86	C	1.00	300
LTHL	Halide Light Flx	L	2	1495.00	2017		96		0.00	2,900
BUILDING SUB-AREA SUMMARY SECTION										
Code	Description	Living Area	Floor Area	Eff Area	Unit Cost	Undeprec Value				
Ttl Gross Liv / Lease Area										