

CURRENT OWNER		TOPO		UTILITIES		STRT / ROAD		LOCATION		CURRENT ASSESSMENT				801 FY2025 BARNSTABLE, MA							
KRASKOUSKAS, JANET K 67 CAPTAIN BELLAMY LANE CENTERVILLE MA 02632		1	Level	2	Public Water	1	Paved			Description	Code	Assessed	Assessed			410,700 155,900	410,700 155,900				
		4	Gas							RESIDNTL	1010	410,700									
		6	Septic					3		RES LAND	1010	155,900									
SUPPLEMENTAL DATA																					
		Alt Prcl ID Split Zonin BID Parcel ResExpt Q YES: #DL 1 LOT 9 #DL 2				Plan Ref. 395/90 Land Ct# #SR Life Estate JANET K KRASK PP STATU				Total		566,600	566,600								
		GIS ID F_975660_2703088		Assoc Pid#																	
RECORD OF OWNERSHIP				BK-VOL/PAGE		SALE DATE		Q/U V/I		SALE PRIC		VC		PREVIOUS ASSESSMENTS (HISTORY)							
KRASKOUSKAS, JANET K				35929	347	08-09-2023	U	I		1	1F	Year	Code	Assessed	Year	Code	Assessed	Year	Code	Assessed	
KRASKOUSKAS, JANET K				15676	0164	10-01-2002	U	I		1	1A	2025	1010	410,700	2024	1010	388,500	2023	1010	344,600	
HOWE, BARRY S TR				10392	0059	09-15-1996	U	I		91,000	1		1010	155,900			155,900		1010	141,700	
KRASKOUSKAS, JANET				10172	0067	04-15-1996	Q	I		130,000	00										
MARKHAM, JAMES E & LINDA A				8034	0204	05-15-1992	Q	I		110,000	00										
		Total										566,600		Total		544,400		Total		486,300	
EXEMPTIONS				OTHER ASSESSMENTS																	
Year	Code	Description		Amount		Code	Description		Number	Amount		Comm Int		This signature acknowledges a visit by a Data Collector or Assessor							
2025	5C	RESIDENTIAL EXEMPTION																			
		Total		0.00																	
ASSESSING NEIGHBORHOOD																					
Nbhd		Nbhd Name				B		Tracing				Batch									
0105												CENVIL									
NOTES																					
BUILDING PERMIT RECORD																					
Permit Id	Issue Date	Type	Description	Amount	Insp Date	% Comp	Date Comp	Comments				Date	Id	Type	Is	Cd	Purpost/Result				
201104255	08-30-2011	RE	Remodel	1,000	12-22-2011	100	06-30-2012	INSULATE-SHTRCK GAR FO				07-11-2024	EG	03		16	In Office Review				
201005734	11-30-2010	WD	Wood Deck	8,000	06-14-2011	100	06-30-2011	REBLD EXIST WDCK 12X24				04-20-2020	WD			FR	Field Review				
B28205	07-01-1985	DW	Dwelling	0	01-15-1986	100		CE 1.5 ST				03-06-2017	KM	02		03	Cycl Insp Comp				
												01-13-2012	RB	03		16	In Office Review				
LAND LINE VALUATION SECTION																					
B	Use Code	Description	Zone	LA	Land Units	Unit Price	Size Adj	AC Disc	Site Index	Cond.	Nbhd.	Nbhd. Adj	Notes		Location Adjustmen		Adj Unit P	Land Value			
1	1010	Single Fam M-0	RD-	3	0.460	AC	176,344.00	1.92125	1.0000	5	1.00	0105	1.000			1.0000	338,809.7	155,900			
Total Card Land Units					0.46	AC	Parcel Total Land Area					0.46	Total Land Value					155,900			

VISION

CONSTRUCTION DETAIL			CONSTRUCTION DETAIL (CONTINUED)		
Element	Cd	Description	Element	Cd	Description
Style	04	Cape Cod			
Model	01	Residential			
Grade:	C	Average			
Stories	1.75	1 3/4 Stories			
Exterior Wall 1	14	Wood Shingle			
Exterior Wall 2	11	Clapboard			
Roof Structure	03	Gable/Hip			
Roof Cover	03	Asph/F Gls/Cmp			
Interior Wall 1	05	Drywall			
Interior Wall 2					
Interior Floor 1	14	Carpet			
Interior Floor 2	05	Vinyl/Asphalt			
Heat Fuel	03	Gas			
Heat Type	04	Hot Air			
AC Type	03	Central			
Bedrooms	03	3 Bedrooms			
Full Baths	2				
Half Baths	0				
Extra Fixtures					
Total Rooms	6	6 Rooms			
Bath Style					
Kitchen Style					
Occupancy					
Sewer Occupan					
Accessory Apt					
Foundation Alt	01	Poured Conc.			
Rms Prts					
Bath Split	20	2 Full-0 Half			

CONDO DATA			
Parcel Id	C	Ownr	0.0
Adjust Type	Code	Description	Factor%
Condo Flr	Condo Unit		

COST / MARKET VALUATION	
Building Value New	445,161
Year Built	1985
Effective Year Built	2002
Depreciation Code	A
Remodel Rating	
Year Remodeled	
Depreciation %	17
Functional Obsol	0
External Obsol	0
Trend Factor	1
Condition	
Condition %	
Percent Good	83
RCNLD	369,500
Dep % Ovr	
Dep Ovr Comment	
Misc Imp Ovr	
Misc Imp Ovr Comment	
Cost to Cure Ovr	
Cost to Cure Ovr Comment	

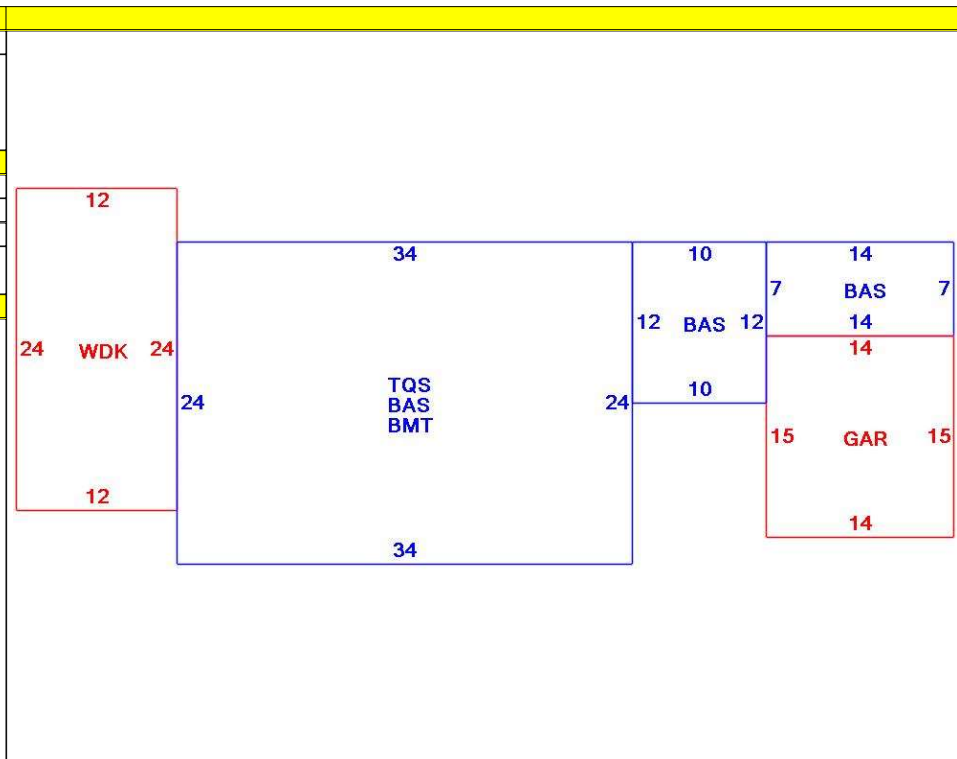

OB - OUTBUILDING & YARD ITEMS(L) / XF - BUILDING EXTRA FEATURES(B)										
Code	Description	L/B	Units	Unit Price	Yr Blt	Cond. Cd	% Gd	Grade	Grade Adj.	Appr. Value
FPL2	Fireplace 1.5 s	B	1	6000.00	2000		83		0.00	5,000
WDC	Deck comp w	L	288	28.00	2011		84		0.00	6,900
GAR	Attached Gara	B	210	40.00	2000		83		0.00	8,500
BMT	Basement-Unfi	B	816	26.01	2000		83		0.00	19,100
SHED	Shed	L	96	18.00	2017		96		0.00	1,700

BUILDING SUB-AREA SUMMARY SECTION						
Code	Description	Living Area	Floor Area	Eff Area	Unit Cost	Undeprec Value
BAS	First Floor	1,034	1,034	1,034	284.63	294,307
BMT	Basement Area	0	816	0	0.00	0
GAR	Attached Garage	0	210	0	0.00	0
TQS	Three Quarter Story	530	816	530	184.87	150,854
WDK	Wood Deck	0	288	0	0.00	0
Ttl Gross Liv / Lease Area		1,564	3,164	1,564		445,161

