

CURRENT OWNER		TOPO	UTILITIES	STRT / ROAD	LOCATION	CURRENT ASSESSMENT						
MASTERTON, WILLIAM E JR & LINDA  155 LAKESIDE DRIVE  CENTERVILLE MA 02632	3	Below Street	2	Public Water	1	Paved	1	Lake/Pond Fro	Description	Code	Assessed	Assessed
			4	Gas			1	Excel View	RESIDNTL	1010	386,900	386,900
			6	Septic			3		RES LAND	1010	991,700	991,700
<b>SUPPLEMENTAL DATA</b>												
Alt Prcl ID Split Zonin BID Parcel ResExpt Q YES: #DL 1 LOT 130 #DL 2 GIS ID F_976298_2707615					Plan Ref. Land Ct# 20239-C #SR Life Estate PP STATU Assoc Pid#			Total		1,378,600		1,378,600

801  
 FY2025  
 BARNSTABLE, MA

# VISION

RECORD OF OWNERSHIP		BK-VOL/PAGE	SALE DATE	Q/U	V/I	SALE PRIC	VC	PREVIOUS ASSESSMENTS (HISTORY)								
MASTERTON, WILLIAM E JR & LINDA S	C128491	0	11-15-1992	Q	I	300,000	U	Year	Code	Assessed	Year	Code	Assessed	Year	Code	Assessed
FRISHMAN, DANIEL TR	C105304	0	02-15-1986	U	I	1	A	2025	1010	386,900	2024	1010	379,400	2023	1010	329,200
FRISHMAN, DANIEL	C47106	0	10-01-1969	U		0			1010	991,700		1010	991,700		1010	901,600
Total								1,378,600		Total		1,371,100		Total		1,230,800

EXEMPTIONS				OTHER ASSESSMENTS				This signature acknowledges a visit by a Data Collector or Assessor													
Year	Code	Description	Amount	Code	Description	Number	Amount	Comm Int													
2010	5C	RESIDENTIAL EXEMPTION	0.00																		
Total			0.00																		

ASSESSING NEIGHBORHOOD				APPRAISED VALUE SUMMARY													
Nbhd	Nbhd Name		B	Tracing		Batch											
0114						CENVIL											
NOTES																	
Total Appraised Parcel Value								1,378,600									

BUILDING PERMIT RECORD										VISIT / CHANGE HISTORY						
Permit Id	Issue Date	Type	Description	Amount	Insp Date	% Comp	Date Comp	Comments			Date	Id	Type	Is	Cd	Purpost/Result
											07-21-2021	SR	02		03	Cycl Insp Comp
											04-30-2020	WD			FR	Field Review
											02-01-2010	PT	02		14	Cyclical Inspection
											10-25-2000	PT	01		00	Meas/Listed-Interior Acces

LAND LINE VALUATION SECTION																		
B	Use Code	Description	Zone	LA	Land Units	Unit Price	Size Adj	AC Disc	Site Index	Cond.	Nbhd.	Nbhd. Adj	Notes		Location Adjustmen	Adj Unit P	Land Value	
1	1010	Single Fam M-0	RD-	3	0.360	AC	176,344.00	2.40337	1.0000	5	1.00	0114	6.500	WEQUAQUET LAKE		1.0000	2,754,828	991,700
Total Card Land Units					0.36	AC	Parcel Total Land Area					0.36	Total Land Value					991,700

CONSTRUCTION DETAIL			CONSTRUCTION DETAIL (CONTINUED)		
Element	Cd	Description	Element	Cd	Description
Style	01	Ranch			
Model	01	Residential			
Grade:	C+	Average Plus			
Stories	1	1 Story			
Exterior Wall 1	14	Wood Shingle			
Exterior Wall 2	11	Clapboard			
RooF Structure	03	Gable/Hip			
RooF Cover	03	Asph/F Gls/Cmp			
Interior Wall 1	05	Drywall			
Interior Wall 2					
Interior Floor 1	12	Hardwood			
Interior Floor 2	14	Carpet			
Heat Fuel	03	Gas			
Heat Type	04	Hot Air			
AC Type	01	None			
Bedrooms	03	3 Bedrooms			
Full Baths	1				
Half Baths	1				
Extra Fixtures					
Total Rooms	7	7 Rooms			
Bath Style					
Kitchen Style					
Occupancy					
Sewer Occupan					
Accessory Apt					
Foundation Alt	01	Poured Conc.			
Rms Prts					
Bath Split	11	1 Full-1 Half			

CONDO DATA			
Parcel Id	C	B	S
Adjust Type	Code	Description	Factor%
Condo Flr			
Condo Unit			

COST / MARKET VALUATION	
Building Value New	437,795
Year Built	1960
Effective Year Built	1990
Depreciation Code	A
Remodel Rating	
Year Remodeled	
Depreciation %	26
Functional Obsol	0
External Obsol	0
Trend Factor	1
Condition	
Condition %	
Percent Good	74
RCNLD	324,000
Dep % Ovr	
Dep Ovr Comment	
Misc Imp Ovr	
Misc Imp Ovr Comment	
Cost to Cure Ovr	
Cost to Cure Ovr Comment	

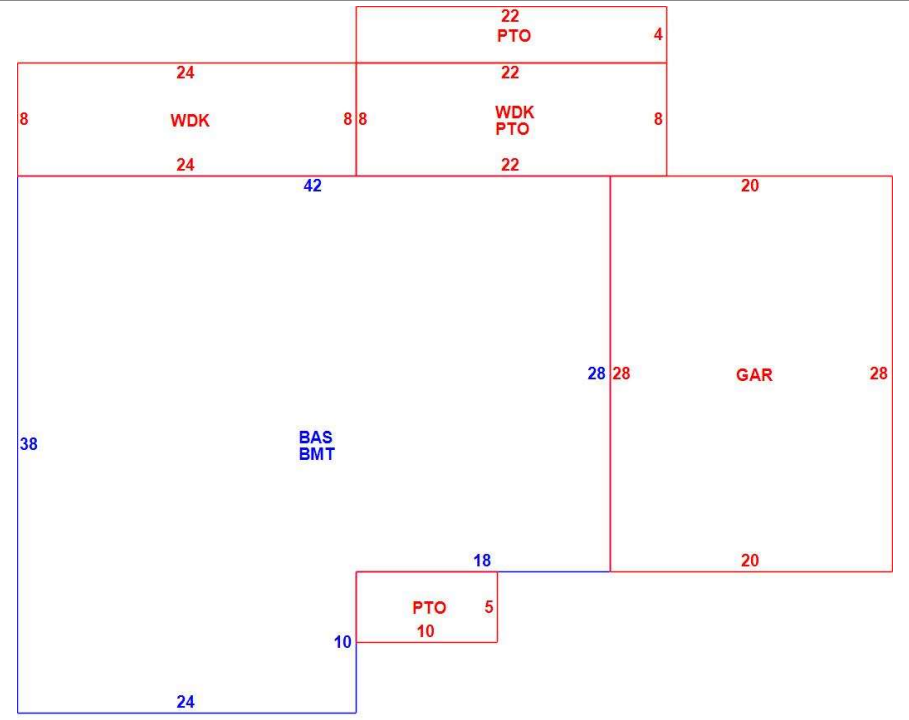

OB - OUTBUILDING & YARD ITEMS(L) / XF - BUILDING EXTRA FEATURES(B)										
Code	Description	L/B	Units	Unit Price	Yr Blt	Cond. Cd	% Gd	Grade	Grade Adj.	Appr. Value
FPL1	Fireplace 1 sto	B	1	5000.00	1988		74		0.00	3,700
BFA	Bsmt Fin-Avg	B	700	17.36	1988		74		0.00	9,000
WDC	Wood Decking	L	368	20.00	1993		48		0.00	3,400
GAR	Attached Gara	B	560	40.00	1988		74		0.00	14,800
BMT	Basement-Unfi	B	1,416	26.01	1988		74		0.00	25,200
PATF	Flagstone Pav	L	314	30.00	1996		72		0.00	6,800

BUILDING SUB-AREA SUMMARY SECTION						
Code	Description	Living Area	Floor Area	Eff Area	Unit Cost	Undeprec Value
BAS	First Floor	1,416	1,416	1,416	309.18	437,795
BMT	Basement Area	0	1,416	0	0.00	0
GAR	Attached Garage	0	560	0	0.00	0
PTO	Patio	0	314	0	0.00	0
WDK	Wood Deck	0	368	0	0.00	0
Ttl Gross Liv / Lease Area		1,416	4,074	1,416		437,795

