

CURRENT OWNER		TOPO	UTILITIES	STRT / ROAD	LOCATION	CURRENT ASSESSMENT			
TSCHAIKOWSKY, GREGORY N & MO TSCHAIKOWSKY, PAULETTE L 82 BELLOT ROAD RINGWOOD NJ 07456		1 Level	2 Public Water	1 Paved		Description RESIDNTL RES LAND	Code 1010 1010	Assessed 266,700 214,500	Assessed 266,700 214,500
			4 Gas						
			6 Septic		3				
SUPPLEMENTAL DATA									
Alt Prcl ID Split Zonin BID Parcel ResExpt Q #DL 1 LOT 9 #DL 2 GIS ID F_978065_2696497				Plan Ref. 116/73 Land Ct# #SR Life Estate PP STATU Assoc Pid#		Total 481,200 481,200			

801
 FY2025
 BARNSTABLE, MA

VISION

RECORD OF OWNERSHIP		BK-VOL/PAGE	SALE DATE	Q/U	V/I	SALE PRIC	VC	PREVIOUS ASSESSMENTS (HISTORY)					
TSCHAIKOWSKY, GREGORY N & MOTTA		28533 0208	11-26-2014	Q	I	285,000	00	Year	Code	Assessed	Year	Code	Assessed
BOUTSELIS, NICHOLAS & MAXIMINA A		25055 0059	12-03-2010	Q	I	249,500	00	2025	1010	266,700	2024	1010	264,600
CRAIGVILLE REALTY, INC		24758 0182	08-17-2010	U	I	144,900	1S		1010	214,500	2023	1010	228,100
FEDERAL NATIONAL MORTGAGE ASSO		24348 0044	02-03-2010	U	I	173,838	1L						195,000
HOLMES, STEPHEN M		13217 0097	08-31-2000	Q	I	140,000	00	Total		481,200	Total		479,100
								Total		423,100	Total		423,100

EXEMPTIONS			OTHER ASSESSMENTS					
Year	Code	Description	Amount	Code	Description	Number	Amount	Comm Int
Total			0.00					

This signature acknowledges a visit by a Data Collector or Assessor

ASSESSING NEIGHBORHOOD				
Nbhd	Nbhd Name	B	Tracing	Batch
0107				CENVIL

APPRAISED VALUE SUMMARY	
Appraised Bldg. Value (Card)	231,500
Appraised Xf (B) Value (Bldg)	30,900
Appraised Ob (B) Value (Bldg)	4,300
Appraised Land Value (Bldg)	214,500
Special Land Value	0
Total Appraised Parcel Value	481,200
Valuation Method	C
Total Appraised Parcel Value	481,200

NOTES									

BUILDING PERMIT RECORD								VISIT / CHANGE HISTORY						
Permit Id	Issue Date	Type	Description	Amount	Insp Date	% Comp	Date Comp	Comments	Date	Id	Type	Is	Cd	Purpost/Result
18-3040	09-13-2018	835	Sid/Wind/Roof/	0		100		(1) Window Replacement	05-21-2020	WD			FR	Field Review
201507057	11-09-2015	SH	Shed	35	06-07-2016	100	06-30-2016	INSTALL A 10X12 SHED	06-07-2016	RB	03		16	In Office Review
									04-02-2010	PT	02		14	Cyclical Inspection
									10-15-1991	ME	02		01	Meas/Est

LAND LINE VALUATION SECTION																	
B	Use Code	Description	Zone	LA	Land Units	Unit Price	Size Adj	AC Disc	Site Index	Cond.	Nbhd.	Nbhd. Adj	Notes	Location Adjustmen	Adj Unit P	Land Value	
1	1010	Single Fam M-0	RB	3	0.380	AC	176,344.00	2.28665	1.0000	5	1.00	0107	1.400		1.0000	564,530.0	214,500
Total Card Land Units					0.38	AC	Parcel Total Land Area					0.38	Total Land Value			214,500	

CONSTRUCTION DETAIL			CONSTRUCTION DETAIL (CONTINUED)		
Element	Cd	Description	Element	Cd	Description
Style	01	Ranch			
Model	01	Residential			
Grade:	C	Average			
Stories	1	1 Story			
Exterior Wall 1	14	Wood Shingle			
Exterior Wall 2					
RooF Structure	03	Gable/Hip			
RooF Cover	03	Asph/F Gls/Cmp			
Interior Wall 1	05	Drywall			
Interior Wall 2					
Interior Floor 1	12	Hardwood			
Interior Floor 2					
Heat Fuel	03	Gas			
Heat Type	05	Hot Water			
AC Type	01	None			
Bedrooms	03	3 Bedrooms			
Full Baths	1				
Half Baths	0				
Extra Fixtures					
Total Rooms	6	6 Rooms			
Bath Style					
Kitchen Style					
Occupancy					
Sewer Occupan					
Accessory Apt					
Foundation Alt	02	Conc. Block			
Rms Prts					
Bath Split	10	1 Full-0 Half			
CONDO DATA					
Parcel Id		C	Owne	0.0	
Adjust Type	Code	Description	Factor%		
Condo Flr					
Condo Unit					
COST / MARKET VALUATION					
Building Value New		326,027			
Year Built		1954			
Effective Year Built		1987			
Depreciation Code		A			
Remodel Rating					
Year Remodeled					
Depreciation %		29			
Functional Obsol		0			
External Obsol		0			
Trend Factor		1			
Condition					
Condition %					
Percent Good		71			
RCNLD		231,500			
Dep % Ovr					
Dep Ovr Comment					
Misc Imp Ovr					
Misc Imp Ovr Comment					
Cost to Cure Ovr					
Cost to Cure Ovr Comment					

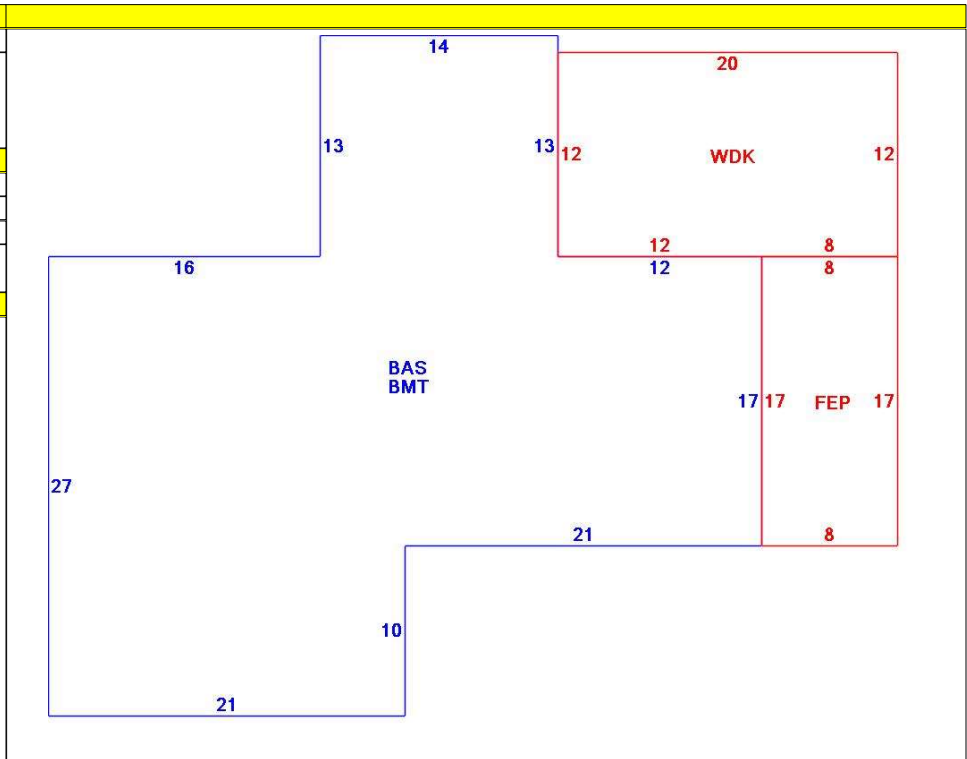

OB - OUTBUILDING & YARD ITEMS(L) / XF - BUILDING EXTRA FEATURES(B)										
Code	Description	L/B	Units	Unit Price	Yr Blt	Cond. Cd	% Gd	Grade	Grade Adj.	Appr. Value
FPL1	Fireplace 1 sto	B	1	5000.00	1985		71		0.00	3,600
WDC	Wood Decking	L	240	20.00	1991		44		0.00	2,300
FEP	Enclosed porc	B	136	70.00	1985		71		0.00	7,100
BMT	Basement-Unfi	B	1,106	26.01	1985		71		0.00	20,200
SHED	Shed	L	120	18.00	2016		94		0.00	2,000

BUILDING SUB-AREA SUMMARY SECTION						
Code	Description	Living Area	Floor Area	Eff Area	Unit Cost	Undeprec Value
BAS	First Floor	1,106	1,106	1,106	294.78	326,027
BMT	Basement Area	0	1,106	0	0.00	0
FEP	Enclosed Porch	0	136	0	0.00	0
WDK	Wood Deck	0	240	0	0.00	0
Ttl Gross Liv / Lease Area		1,106	2,588	1,106		326,027

