

CONSTRUCTION DETAIL			CONSTRUCTION DETAIL (CONTINUED)		
Element	Cd	Description	Element	Cd	Description
Style	01	Ranch			
Model	01	Residential			
Grade:	C	Average			
Stories	1	1 Story			
Exterior Wall 1	25	Vinyl Siding			
Exterior Wall 2					
Roof Structure	03	Gable/Hip			
Roof Cover	03	Asph/F Gls/Cmp			
Interior Wall 1	05	Drywall			
Interior Wall 2					
Interior Floor 1	14	Carpet			
Interior Floor 2					
Heat Fuel	03	Gas			
Heat Type	04	Hot Air			
AC Type	03	Central			
Bedrooms	02	2 Bedrooms			
Full Baths	2				
Half Baths	0				
Extra Fixtures					
Total Rooms	5	5 Rooms			
Bath Style					
Kitchen Style					
Occupancy					
Sewer Occupan					
Accessory Apt					
Foundation Alt	01	Poured Conc.			
Rms Prts					
Bath Split	20	2 Full-0 Half			

CONDO DATA			
Parcel Id		C	Owne 0.0
		B	S
Adjust Type	Code	Description	Factor%
Condo Fir			
Condo Unit			

COST / MARKET VALUATION		
Building Value New		368,880
Year Built	1973	
Effective Year Built	1996	
Depreciation Code	A	
Remodel Rating		
Year Remodeled		
Depreciation %	22	
Functional Obsol	0	
External Obsol	0	
Trend Factor	1	
Condition		
Condition %		
Percent Good	78	
RCNLD	287,700	
Dep % Ovr		
Dep Ovr Comment		
Misc Imp Ovr		
Misc Imp Ovr Comment		
Cost to Cure Ovr		
Cost to Cure Ovr Comment		

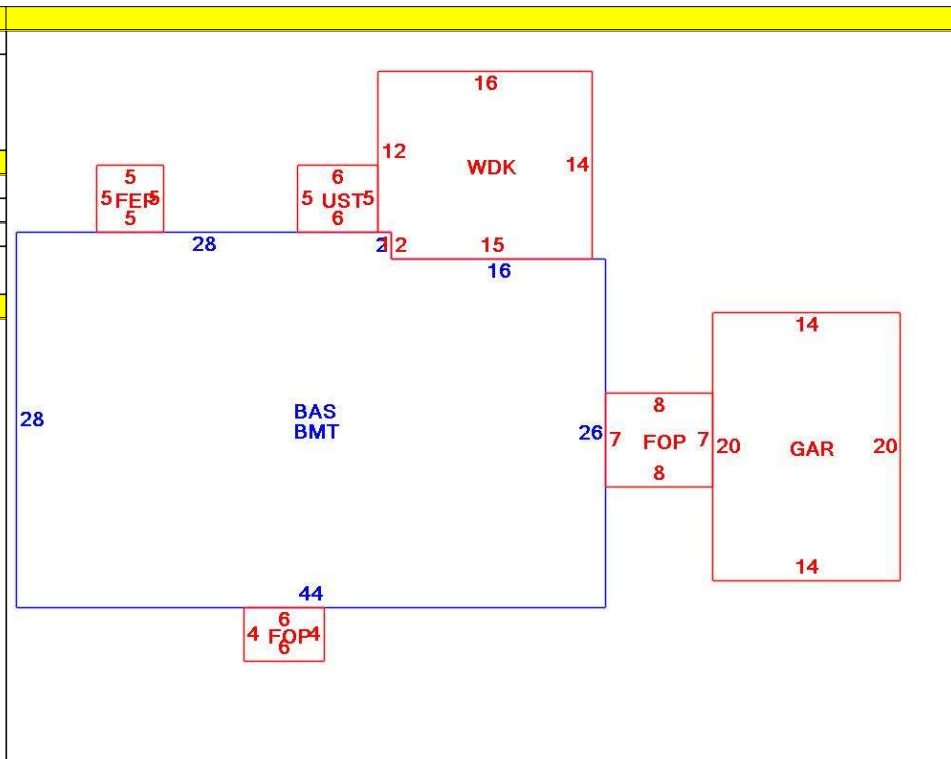

OB - OUTBUILDING & YARD ITEMS(L) / XF - BUILDING EXTRA FEATURES(B)										
Code	Description	L/B	Units	Unit Price	Yr Blt	Cond. Cd	% Gd	Grade	Grade Adj.	Appr. Value
FPL1	Fireplace 1 sto	B	1	5000.00	1994		78		0.00	3,900
WDC	Wood Decking	L	222	20.00	1996		54		0.00	2,700
FOP	Open Porch-ro	B	80	55.00	1994		78		0.00	3,700
GAR	Attached Gara	B	280	40.00	1994		78		0.00	9,900
UST	Utility Storage-	B	30	17.11	1994		78		0.00	400
BMT	Basement-Unfi	B	1,200	26.01	1994		78		0.00	23,300
FEP	Enclosed porc	B	25	70.00	1994		78		0.00	2,700
SHED	Shed	L	80	18.00	2019		100		0.00	1,400

BUILDING SUB-AREA SUMMARY SECTION						
Code	Description	Living Area	Floor Area	Eff Area	Unit Cost	Undeprec Value
BAS	First Floor	1,200	1,200	1,200	307.40	368,880
BMT	Basement Area	0	1,200	0	0.00	0
FEP	Enclosed Porch	0	25	0	0.00	0
FOP	Open Porch	0	80	0	0.00	0
GAR	Attached Garage	0	280	0	0.00	0
UST	Utility Enclosure	0	30	0	0.00	0
WDK	Wood Deck	0	222	0	0.00	0
Ttl Gross Liv / Lease Area		1,200	3,037	1,200		368,880

