

CONSTRUCTION DETAIL			CONSTRUCTION DETAIL (CONTINUED)		
Element	Cd	Description	Element	Cd	Description
Style	01	Ranch			
Model	01	Residential			
Grade:	C	Average			
Stories	1	1 Story			
Exterior Wall 1	14	Wood Shingle			
Exterior Wall 2					
RooF Structure	03	Gable/Hip			
RooF Cover	03	Asph/F Gls/Cmp			
Interior Wall 1	05	Drywall			
Interior Wall 2					
Interior Floor 1	14	Carpet			
Interior Floor 2	12	Hardwood			
Heat Fuel	03	Gas			
Heat Type	05	Hot Water			
AC Type	01	None			
Bedrooms	03	3 Bedrooms			
Full Baths	3				
Half Baths	0				
Extra Fixtures					
Total Rooms	7	7 Rooms			
Bath Style					
Kitchen Style					
Occupancy					
Sewer Occupan					
Accessory Apt					
Foundation Alt	01	Poured Conc.			
Rms Prts					
Bath Split	30	3 Full-0 Half			

CONDO DATA			
Parcel Id		C	Owne 0.0
		B	S
Adjust Type	Code	Description	Factor%
Condo Flr			
Condo Unit			

COST / MARKET VALUATION	
Building Value New	497,334
Year Built	1960
Effective Year Built	1990
Depreciation Code	A
Remodel Rating	
Year Remodeled	
Depreciation %	26
Functional Obsol	0
External Obsol	0
Trend Factor	1
Condition	
Condition %	
Percent Good	74
RCNLD	368,000
Dep % Ovr	
Dep Ovr Comment	
Misc Imp Ovr	
Misc Imp Ovr Comment	
Cost to Cure Ovr	
Cost to Cure Ovr Comment	

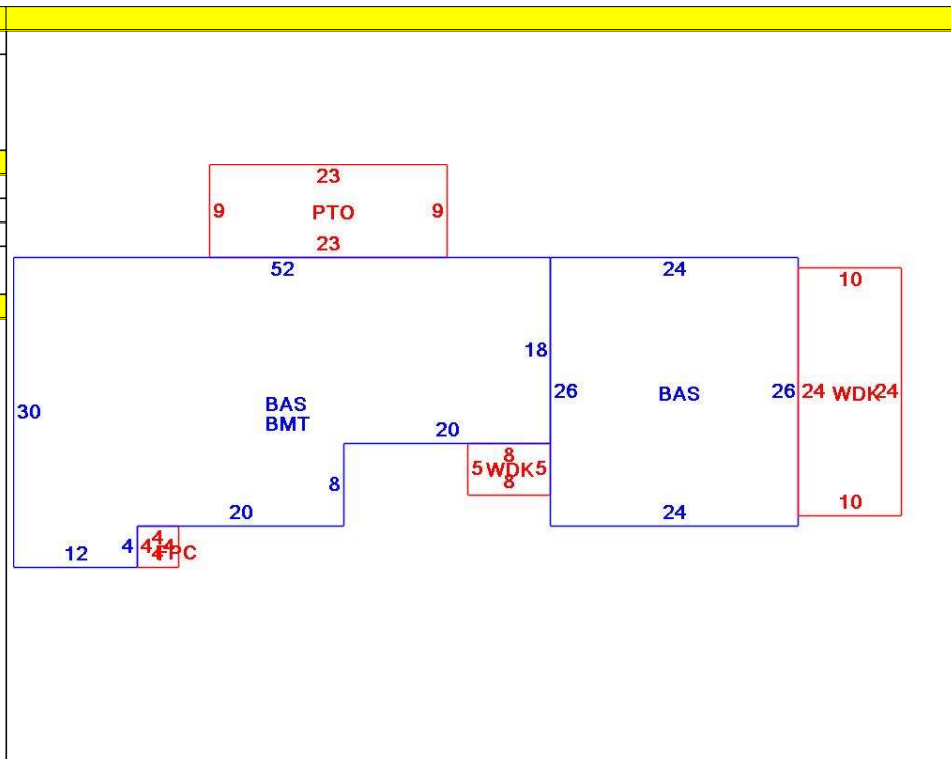

OB - OUTBUILDING & YARD ITEMS(L) / XF - BUILDING EXTRA FEATURES(B)										
Code	Description	L/B	Units	Unit Price	Yr Blt	Cond. Cd	% Gd	Grade	Grade Adj.	Appr. Value
FPL1	Fireplace 1 sto	B	1	5000.00	1988		74		0.00	3,700
SHED	Shed	L	160	18.00	1990		42		0.00	1,200
FGR7	Gar w/Lft Goo	L	576	70.00	2005		81	00	1.00	32,700
WDC	Wood Decking	L	240	20.00	1993		48		0.00	2,500
PAT1	Patio- Average	L	207	5.89	1993		74		0.00	1,000
FOPC	Open Prch-roo	B	16	55.00	1988		74		0.00	1,000
BMT	Basement-Unfi	B	1,240	26.01	1988		74		0.00	22,700
WDC	Wood Deck w/	L	40	18.00	2015		92		0.00	2,100

BUILDING SUB-AREA SUMMARY SECTION						
Code	Description	Living Area	Floor Area	Eff Area	Unit Cost	Undeprec Value
BAS	First Floor	1,864	1,864	1,864	266.81	497,334
BMT	Basement Area	0	1,240	0	0.00	0
FPC	Open Porch Conc. Floor	0	16	0	0.00	0
PTO	Patio	0	207	0	0.00	0
WDK	Wood Deck	0	280	0	0.00	0
Ttl Gross Liv / Lease Area		1,864	3,607	1,864		497,334

