

| CURRENT OWNER | | TOPO | | UTILITIES | | STRT / ROAD | | LOCATION | | CURRENT ASSESSMENT | | | |
|----------------------------------------------------------------------------------------------------------|--|------|--------|-----------|-------------------------------------------------------------------------------|-------------|-------|----------|--|--------------------|------|----------|----------|
| WILLIAMS, REMIE K 595 PHINNEY'S LANE CENTERVILLE MA 02632 | | 1 | Level | 2 | Public Water | 1 | Paved | | | Description | Code | Assessed | Assessed |
| | | 4 | Gas | | | | | | | RESIDNTL | 1010 | 273,200 | 273,200 |
| | | 6 | Septic | | | | | 3 | | RES LAND | 1010 | 157,200 | 157,200 |
| SUPPLEMENTAL DATA | | | | | | | | | | | | | |
| Alt Prcl ID Split Zonin BID Parcel ResExpt Q #DL 1 LOT 1 #DL 2 GIS ID F_976436_2704504 | | | | | Plan Ref. 237/117 Land Ct# #SR Life Estate PP STATU Assoc Pid# | | | | | Total | | 430,400 | 430,400 |

801
FY2025
BARNSTABLE, MA

VISION

| RECORD OF OWNERSHIP | | BK-VOL/PAGE | | SALE DATE | | Q/U | | V/I | | SALE PRIC | | VC | | PREVIOUS ASSESSMENTS (HISTORY) | | | | | | | | |
|--------------------------|--|-------------|------|------------|--|-----|---|-----|--|-----------|--|----|--|--------------------------------|------|----------|-------|------|----------|-------|------|----------|
| WILLIAMS, REMIE K | | 36633 | 310 | 10-24-2024 | | Q | I | | | 490,000 | | 00 | | Year | Code | Assessed | Year | Code | Assessed | Year | Code | Assessed |
| FAY, JOHN F | | 30013 | 0218 | 10-18-2016 | | Q | I | | | 230,000 | | 00 | | 2025 | 1010 | 273,200 | 2024 | 1010 | 268,200 | 2023 | 1010 | 227,100 |
| MCCANN, SHAUN A & NOELLE | | 16293 | 0021 | 01-27-2003 | | U | I | | | 85,233 | | 1A | | | 1010 | 157,200 | | 1010 | 157,200 | | 1010 | 142,900 |
| MCCANN, FITZJOHN W | | 10162 | 0317 | 04-23-1996 | | Q | I | | | 85,000 | | U | | | | | | | | | | |
| BRANTON, WILLIAM E | | 3121 | 0335 | 07-10-1980 | | U | | | | 0 | | | | Total | | 430,400 | Total | | 425,400 | Total | | 370,000 |

| EXEMPTIONS | | | | OTHER ASSESSMENTS | | | | This signature acknowledges a visit by a Data Collector or Assessor | | | | | | | | | | | |
|------------|------|-------------|--------|-------------------|-------------|--------|--------|---------------------------------------------------------------------|--|--|--|--|--|--|--|--|--|--|--|
| Year | Code | Description | Amount | Code | Description | Number | Amount | Comm Int | | | | | | | | | | | |
| | | | Total | 0.00 | | | | | | | | | | | | | | | |

| ASSESSING NEIGHBORHOOD | | | | APPRAISED VALUE SUMMARY | | | | | | | |
|------------------------|-----------|---|---------|------------------------------|------------------------------|-------------------------------|-------------------------------|-----------------------------|--------------------|------------------------------|------------------|
| Nbhd | Nbhd Name | B | Tracing | Batch | Appraised Bldg. Value (Card) | Appraised Xf (B) Value (Bldg) | Appraised Ob (B) Value (Bldg) | Appraised Land Value (Bldg) | Special Land Value | Total Appraised Parcel Value | Valuation Method |
| 0105 | | | | CENVIL | 223,600 | 45,900 | 3,700 | 157,200 | 0 | 430,400 | C |
| | | | | Total Appraised Parcel Value | | | | 430,400 | | | |

| BUILDING PERMIT RECORD | | | | | | | | | VISIT / CHANGE HISTORY | | | | | |
|------------------------|------------|------|----------------|--------|------------|--------|------------|---------------------------------|------------------------|----|------|----|----|----------------------------|
| Permit Id | Issue Date | Type | Description | Amount | Insp Date | % Comp | Date Comp | Comments | Date | Id | Type | Is | Cd | Purpost/Result |
| 16-3528 | 09-28-2017 | 835 | Sid/Wind/Roof/ | 10,000 | 06-30-2018 | 100 | 06-30-2018 | Reroof (stripping old shingles) | 11-16-2022 | BM | 03 | | 16 | In Office Review |
| | | | | | | | | | 12-22-2021 | SR | 02 | | 03 | Cycl Insp Comp |
| | | | | | | | | | 04-17-2020 | WD | | | FR | Field Review |
| | | | | | | | | | 11-20-2000 | PT | 01 | | 00 | Meas/Listed-Interior Acces |

| LAND LINE VALUATION SECTION | | | | | | | | | | | | | | | | | | |
|-----------------------------|----------|----------------|------|----|------------|------------|------------------------|---------|------------|-------|-------|-----------|------------------|--------------------|------------|------------|---------|---------|
| B | Use Code | Description | Zone | LA | Land Units | Unit Price | Size Adj | AC Disc | Site Index | Cond. | Nbhd. | Nbhd. Adj | Notes | Location Adjustmen | Adj Unit P | Land Value | | |
| 1 | 1010 | Single Fam M-0 | RD- | 3 | 0.500 | AC | 176,344.00 | 1.78240 | 1.0000 | 5 | 1.00 | 0105 | 1.000 | | 1.0000 | 314,315.5 | 157,200 | |
| Total Card Land Units | | | | | 0.50 | AC | Parcel Total Land Area | | | | | 0.50 | Total Land Value | | | | | 157,200 |

| CONSTRUCTION DETAIL | | | CONSTRUCTION DETAIL (CONTINUED) | | |
|---------------------|----|----------------|---------------------------------|----|-------------|
| Element | Cd | Description | Element | Cd | Description |
| Style | 01 | Ranch | | | |
| Model | 01 | Residential | | | |
| Grade: | C | Average | | | |
| Stories | 1 | 1 Story | | | |
| Exterior Wall 1 | 14 | Wood Shingle | | | |
| Exterior Wall 2 | | | | | |
| RooF Structure | 03 | Gable/Hip | | | |
| RooF Cover | 03 | Asph/F Gls/Cmp | | | |
| Interior Wall 1 | 05 | Drywall | | | |
| Interior Wall 2 | | | | | |
| Interior Floor 1 | 12 | Hardwood | | | |
| Interior Floor 2 | | | | | |
| Heat Fuel | 04 | Electric | | | |
| Heat Type | 07 | Elec Baseboard | | | |
| AC Type | 01 | None | | | |
| Bedrooms | 03 | 3 Bedrooms | | | |
| Full Baths | 1 | | | | |
| Half Baths | 1 | | | | |
| Extra Fixtures | | | | | |
| Total Rooms | 6 | 6 Rooms | | | |
| Bath Style | | | | | |
| Kitchen Style | | | | | |
| Occupancy | | | | | |
| Sewer Occupan | | | | | |
| Accessory Apt | | | | | |
| Foundation Alt | 01 | Poured Conc. | | | |
| Rms Prts | | | | | |
| Bath Split | 11 | 1 Full-1 Half | | | |

| CONDO DATA | | | | |
|-------------|------|-------------|---------|-----|
| Parcel Id | | C | Ownr | 0.0 |
| Adjust Type | Code | Description | Factor% | |
| Condo Flr | | | | |
| Condo Unit | | | | |

| COST / MARKET VALUATION | |
|--------------------------|---------|
| Building Value New | 302,168 |
| Year Built | 1960 |
| Effective Year Built | 1990 |
| Depreciation Code | A |
| Remodel Rating | |
| Year Remodeled | |
| Depreciation % | 26 |
| Functional Obsol | 0 |
| External Obsol | 0 |
| Trend Factor | 1 |
| Condition | |
| Condition % | |
| Percent Good | 74 |
| RCNLD | 223,600 |
| Dep % Ovr | |
| Dep Ovr Comment | |
| Misc Imp Ovr | |
| Misc Imp Ovr Comment | |
| Cost to Cure Ovr | |
| Cost to Cure Ovr Comment | |

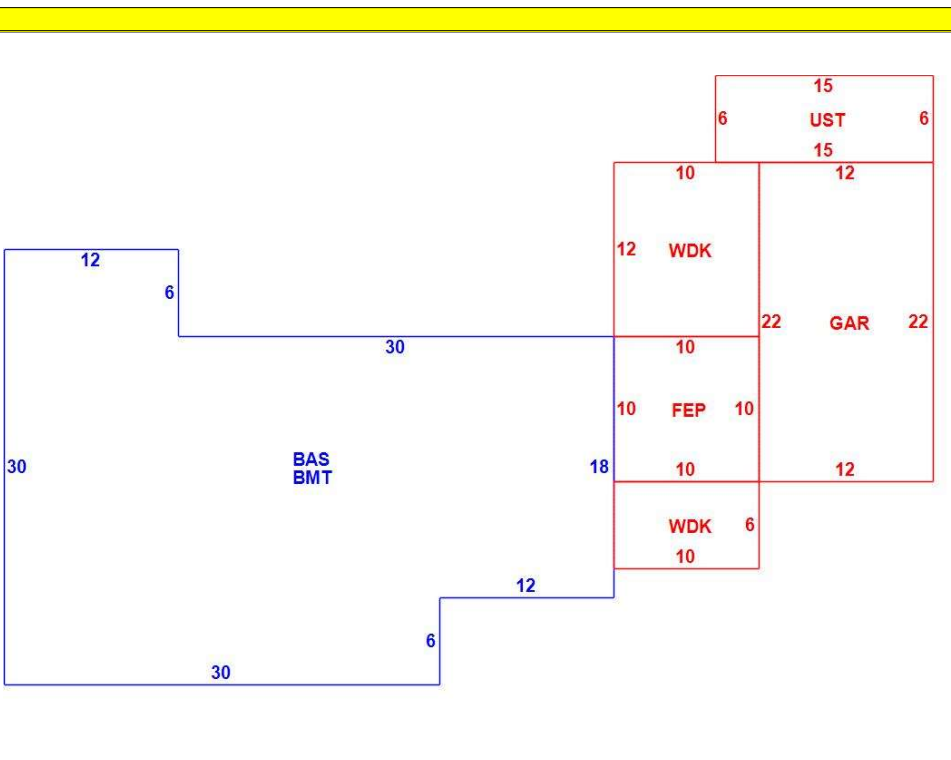

| OB - OUTBUILDING & YARD ITEMS(L) / XF - BUILDING EXTRA FEATURES(B) | | | | | | | | | | |
|--------------------------------------------------------------------|------------------|-----|-------|------------|--------|----------|------|-------|------------|-------------|
| Code | Description | L/B | Units | Unit Price | Yr Blt | Cond. Cd | % Gd | Grade | Grade Adj. | Appr. Value |
| FPL1 | Fireplace 1 sto | B | 1 | 5000.00 | 1988 | | 74 | | 0.00 | 3,700 |
| FEP | Enclosed porc | B | 100 | 70.00 | 1988 | | 74 | | 0.00 | 6,100 |
| GAR | Attached Gara | B | 264 | 40.00 | 1988 | | 74 | | 0.00 | 9,000 |
| UST | Utility Storage- | B | 90 | 17.11 | 1988 | | 74 | | 0.00 | 900 |
| BMT | Basement-Unfi | B | 1,008 | 26.01 | 1988 | | 74 | | 0.00 | 19,800 |
| WDC | Wood Deck w/ | L | 180 | 18.00 | 2020 | | 92 | | 0.00 | 3,700 |
| BFA | Bsmt Fin-Avg | B | 500 | 17.36 | | | 74 | | 0.00 | 6,400 |

| BUILDING SUB-AREA SUMMARY SECTION | | | | | | |
|-----------------------------------|-------------------|-------------|------------|----------|-----------|----------------|
| Code | Description | Living Area | Floor Area | Eff Area | Unit Cost | Undeprec Value |
| BAS | First Floor | 1,008 | 1,008 | 1,008 | 299.77 | 302,168 |
| BMT | Basement Area | 0 | 1,008 | 0 | 0.00 | 0 |
| FEP | Enclosed Porch | 0 | 100 | 0 | 0.00 | 0 |
| GAR | Attached Garage | 0 | 264 | 0 | 0.00 | 0 |
| UST | Utility Enclosure | 0 | 90 | 0 | 0.00 | 0 |
| WDC | Wood Deck | 0 | 180 | 0 | 0.00 | 0 |
| Ttl Gross Liv / Lease Area | | 1,008 | 2,650 | 1,008 | | 302,168 |

