

CURRENT OWNER		TOPO	UTILITIES	STRT / ROAD	LOCATION	CURRENT ASSESSMENT				801 FY2025 BARNSTABLE, MA VISION	
TEMPLE, CHARLES L & SUSAN 118 CAPTAIN ELLIS LANE HYANNIS MA 02601		1 Level	2 Public Water	1 Paved		Description	Code	Assessed	Assessed		
			4 Gas			RESIDNTL	1010	400,000	400,000		
			6 Septic		4	RES LAND	1010	152,600	152,600		
SUPPLEMENTAL DATA						Total				552,600	552,600
Alt Prcl ID Split Zonin BID Parcel ResExpt Q YES: #DL 1 LOT 23 #DL 2 GIS ID F_977992_2704401				Plan Ref. 288/18 Land Ct# #SR Life Estate PP STATU Assoc Pid#							

RECORD OF OWNERSHIP		BK-VOL/PAGE	SALE DATE	Q/U	V/I	SALE PRIC	VC	PREVIOUS ASSESSMENTS (HISTORY)								
TEMPLE, CHARLES L & SUSAN STRACUZZI, CAROLANN M STRACUZZI, JOHN & CAROLANN DUFFLEY, MICHAEL J		26601 0123	08-20-2012	Q	I	225,000	00	Year	Code	Assessed	Year	Code	Assessed	Year	Code	Assessed
		15698 0008	10-04-2002	U	I	1	1A	2025	1010	400,000	2024	1010	396,400	2023	1010	339,900
		4293 0302	10-15-1984	Q	I	73,000	00		1010	152,600			152,600		1010	138,700
		2449 0146	12-30-1976	U		0		Total		552,600	Total		549,000	Total		478,600

EXEMPTIONS				OTHER ASSESSMENTS				This signature acknowledges a visit by a Data Collector or Assessor								
Year	Code	Description	Amount	Code	Description	Number	Amount	Comm Int								
2022	5C	RESIDENTIAL EXEMPTION														
Total			0.00													

ASSESSING NEIGHBORHOOD				APPRAISED VALUE SUMMARY			
Nbhd	Nbhd Name	B	Tracing	Batch			
0105				HYAN			
NOTES				Appraised Bldg. Value (Card)	359,700		
				Appraised Xf (B) Value (Bldg)	30,700		
				Appraised Ob (B) Value (Bldg)	9,600		
				Appraised Land Value (Bldg)	152,600		
				Special Land Value	0		
				Total Appraised Parcel Value	552,600		
				Valuation Method	C		
				Total Appraised Parcel Value	552,600		

BUILDING PERMIT RECORD								VISIT / CHANGE HISTORY						
Permit Id	Issue Date	Type	Description	Amount	Insp Date	% Comp	Date Comp	Comments	Date	Id	Type	Is	Cd	Purpost/Result
SHED-21-4	04-27-2021	863	Shed Registrati	0	05-24-2022	100	06-30-2022	INSULATE ATTIC	05-24-2022	SR	02		02	Bldg Permit Completed
201405609	09-03-2014	IN	Insulation	3,600	06-30-2015	100	06-30-2015		07-07-2021	PK	03		16	In Office Review
									07-01-2021	BM	22		22	Change of Address
									04-20-2020	WD			FR	Field Review
									05-25-2010	PT	02		14	Cyclical Inspection
									05-23-2008	TP	03		16	In Office Review
									01-09-2001	PT	01		00	Meas/Listed-Interior Acces

LAND LINE VALUATION SECTION																
B	Use Code	Description	Zone	LA	Land Units	Unit Price	Size Adj	AC Disc	Site Index	Cond.	Nbhd.	Nbhd. Adj	Notes	Location Adjustmen	Adj Unit P	Land Value
1	1010	Single Fam M-0	RC-	4	0.360 AC	176,344.00	2.40337	1.0000	5	1.00	0105	1.000		1.0000	423,825.1	152,600
Total Card Land Units					0.36	AC	Parcel Total Land Area					0.36	Total Land Value			152,600

CONSTRUCTION DETAIL			CONSTRUCTION DETAIL (CONTINUED)		
Element	Cd	Description	Element	Cd	Description
Style	01	Ranch			
Model	01	Residential			
Grade:	C	Average			
Stories	1	1 Story			
Exterior Wall 1	14	Wood Shingle			
Exterior Wall 2	11	Clapboard			
RooF Structure	03	Gable/Hip			
RooF Cover	03	Asph/F Gls/Cmp			
Interior Wall 1	05	Drywall			
Interior Wall 2					
Interior Floor 1	14	Carpet			
Interior Floor 2	12	Hardwood			
Heat Fuel	03	Gas			
Heat Type	04	Hot Air			
AC Type	03	Central			
Bedrooms	03	3 Bedrooms			
Full Baths	1				
Half Baths	1				
Extra Fixtures					
Total Rooms	6	6 Rooms			
Bath Style					
Kitchen Style					
Occupancy					
Sewer Occupan					
Accessory Apt					
Foundation Alt	01	Poured Conc.			
Rms Prts					
Bath Split	11	1 Full-1 Half			

CONDO DATA			
Parcel Id		C	Owne 0.0
		B	S
Adjust Type	Code	Description	Factor%
Condo Flr			
Condo Unit			

COST / MARKET VALUATION	
Building Value New	449,673
Year Built	1976
Effective Year Built	1998
Depreciation Code	A
Remodel Rating	
Year Remodeled	
Depreciation %	20
Functional Obsol	0
External Obsol	0
Trend Factor	1
Condition	
Condition %	
Percent Good	80
RCNLD	359,700
Dep % Ovr	
Dep Ovr Comment	
Misc Imp Ovr	
Misc Imp Ovr Comment	
Cost to Cure Ovr	
Cost to Cure Ovr Comment	

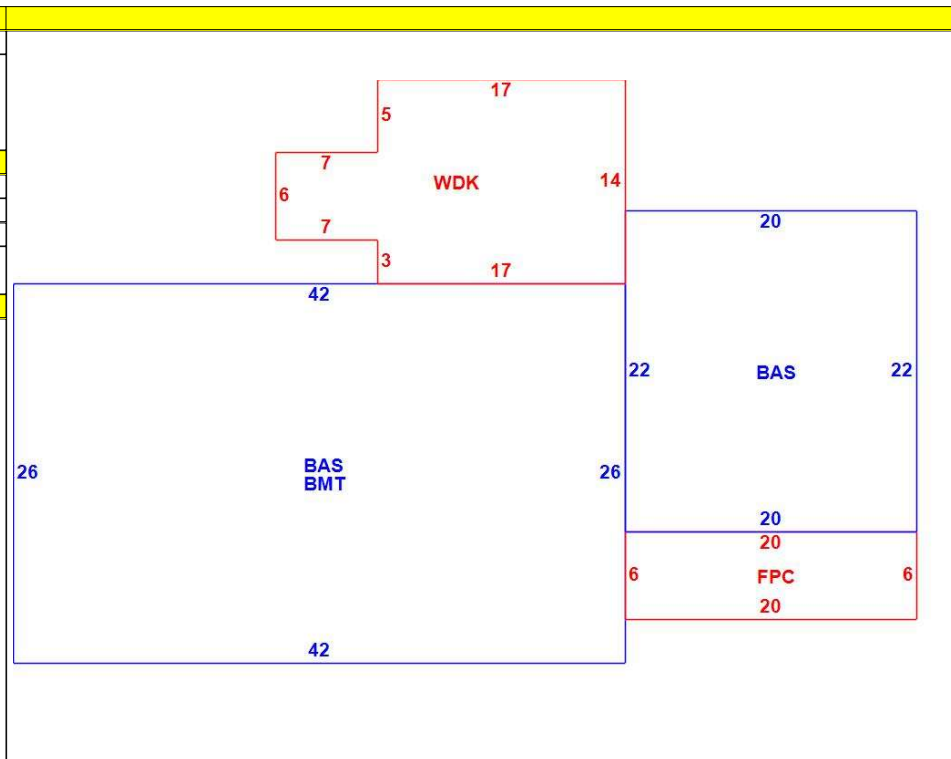

OB - OUTBUILDING & YARD ITEMS(L) / XF - BUILDING EXTRA FEATURES(B)										
Code	Description	L/B	Units	Unit Price	Yr Blt	Cond. Cd	% Gd	Grade	Grade Adj.	Appr. Value
FPL1	Fireplace 1 sto	B	1	5000.00	1996		80		0.00	4,000
WDC	Wood Decking	L	280	20.00	1997		56		0.00	3,200
FOPC	Open Prch-roo	B	120	55.00	1996		80		0.00	4,200
BMT	Basement-Unfi	B	1,092	26.01	1996		80		0.00	22,500
SHED	Shed	L	192	18.00	2022		96		0.00	3,300
PAT2	Patio-Good	L	320	9.94	2022		98		0.00	3,100

BUILDING SUB-AREA SUMMARY SECTION						
Code	Description	Living Area	Floor Area	Eff Area	Unit Cost	Undeprec Value
BAS	First Floor	1,532	1,532	1,532	293.52	449,673
BMT	Basement Area	0	1,092	0	0.00	0
FPC	Open Porch Conc. Floor	0	120	0	0.00	0
WDK	Wood Deck	0	280	0	0.00	0
Ttl Gross Liv / Lease Area		1,532	3,024	1,532		449,673

