

CONSTRUCTION DETAIL			CONSTRUCTION DETAIL (CONTINUED)		
Element	Cd	Description	Element	Cd	Description
Style	03	Colonial			
Model	01	Residential			
Grade:	B	Custom			
Stories	2	2 Stories			
Exterior Wall 1	14	Wood Shingle			
Exterior Wall 2					
Roof Structure	03	Gable/Hip			
Roof Cover	03	Asph/F Gls/Cmp			
Interior Wall 1	03	Plastered			
Interior Wall 2					
Interior Floor 1	12	Hardwood			
Interior Floor 2					
Heat Fuel	03	Gas			
Heat Type	04	Hot Air			
AC Type	03	Central			
Bedrooms	04	4 Bedrooms			
Full Baths	2				
Half Baths	1				
Extra Fixtures					
Total Rooms	7				
Bath Style					
Kitchen Style					
Occupancy					
Sewer Occupan					
Accessory Apt					
Foundation Alt	01	Poured Conc.			
Rms Prts					
Bath Split	21	2 Full-1 Half			
CONDO DATA			COST / MARKET VALUATION		
Parcel Id		C	Ownr	0.0	
Adjust Type	Code	Description	Factor%		
Condo Flr					
Condo Unit					
Building Value New		837,155			
Year Built		2002			
Effective Year Built		2016			
Depreciation Code		G			
Remodel Rating					
Year Remodeled					
Depreciation %		6			
Functional Obsol		0			
External Obsol		0			
Trend Factor		1			
Condition					
Condition %		94			
Percent Good		786,900			
RCNLD					
Dep % Ovr					
Dep Ovr Comment					
Misc Imp Ovr					
Misc Imp Ovr Comment					
Cost to Cure Ovr					
Cost to Cure Ovr Comment					

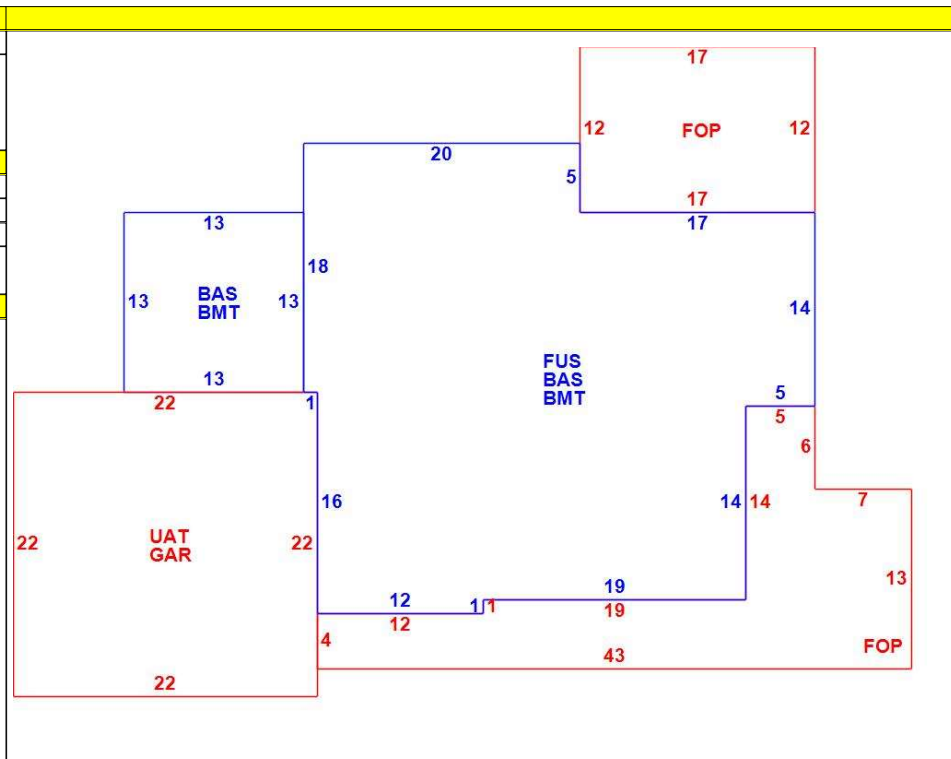

OB - OUTBUILDING & YARD ITEMS(L) / XF - BUILDING EXTRA FEATURES(B)										
Code	Description	L/B	Units	Unit Price	Yr Blt	Cond. Cd	% Gd	Grade	Grade Adj.	Appr. Value
FPLG	Gas Fireplace-	B	3	2500.00	2014		94		0.00	7,100
FOP	Open Porch-ro	B	533	55.00	2014		94		0.00	19,200
GAR	Attached Gara	B	484	40.00	2014		94		0.00	17,100
BMT	Basement-Unfi	B	1,232	26.01	2014		94		0.00	28,700
BFA1	Bsmt Fin-Goo	B	616	32.56	2014		94		0.00	18,900

BUILDING SUB-AREA SUMMARY SECTION						
Code	Description	Living Area	Floor Area	Eff Area	Unit Cost	Undeprec Value
BAS	First Floor	1,232	1,232	1,232	357.30	440,194
BMT	Basement Area	0	1,232	0	0.00	0
FOP	Open Porch	0	533	0	0.00	0
FUS	Upper Story	1,063	1,063	1,063	357.30	379,810
GAR	Attached Garage	0	484	0	0.00	0
UAT	Attic, Unfinished	0	484	48	35.43	17,150
Ttl Gross Liv / Lease Area		2,295	5,028	2,343		837,154

