

CONSTRUCTION DETAIL			CONSTRUCTION DETAIL (CONTINUED)		
Element	Cd	Description	Element	Cd	Description
Style	04	Cape Cod			
Model	01	Residential			
Grade:	C	Average			
Stories	1.75	1 3/4 Stories			
Exterior Wall 1	11	Clapboard			
Exterior Wall 2					
RooF Structure	03	Gable/Hip			
RooF Cover	03	Asph/F Gls/Cmp			
Interior Wall 1	08	Typical			
Interior Wall 2					
Interior Floor 1	14	Carpet			
Interior Floor 2	09	Pine/Soft Wood			
Heat Fuel	03	Gas			
Heat Type	04	Hot Air			
AC Type	03	Central			
Bedrooms	03	3 Bedrooms			
Full Baths	2				
Half Baths	0				
Extra Fixtures					
Total Rooms	7				
Bath Style					
Kitchen Style					
Occupancy					
Sewer Occupan					
Accessory Apt					
Foundation Alt	01	Poured Conc.			
Rms Prts					
Bath Split	20	2 Full-0 Half			

CONDO DATA			
Parcel Id		C	Owne 0.0
Adjust Ttpe	Code	Description	Factor%
Condo Flr			
Condo Unit			

COST / MARKET VALUATION	
Building Value New	487,787
Year Built	1978
Effective Year Built	1999
Depreciation Code	A
Remodel Rating	
Year Remodeled	
Depreciation %	19
Functional Obsol	0
External Obsol	0
Trend Factor	1
Condition	
Condition %	
Percent Good	81
RCNLD	395,100
Dep % Ovr	
Dep Ovr Comment	
Misc Imp Ovr	
Misc Imp Ovr Comment	
Cost to Cure Ovr	
Cost to Cure Ovr Comment	

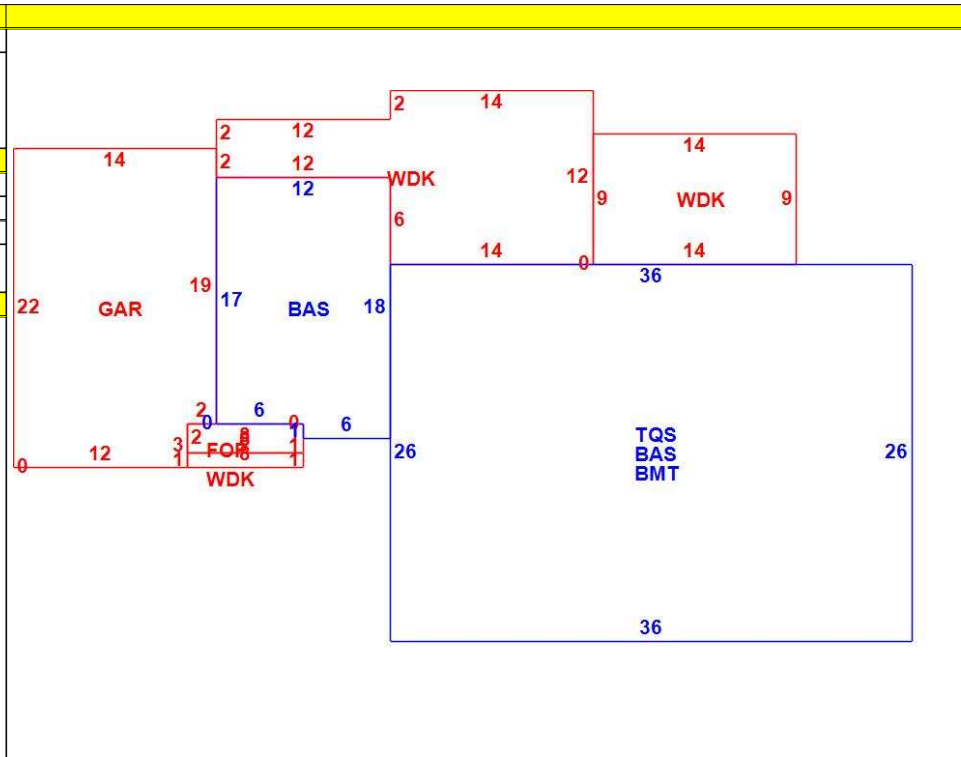

OB - OUTBUILDING & YARD ITEMS(L) / XF - BUILDING EXTRA FEATURES(B)										
Code	Description	L/B	Units	Unit Price	Yr Blt	Cond. Cd	% Gd	Grade	Grade Adj.	Appr. Value
GAR	Attached Gara	B	302	40.00	1997		81		0.00	10,900
BMT	Basement-Unfi	B	936	26.01	1997		81		0.00	20,600
WDC	Wood Deck w/	L	134	18.00	2017		96		0.00	3,400
WDC	Wood Decking	L	216	20.00	2017		96		0.00	4,800
FOP	Open Porch-ro	B	16	55.00	1997		81		0.00	1,200
BFA	Bsmnt Fin-Avg	B	836	17.36			81		0.00	11,800

BUILDING SUB-AREA SUMMARY SECTION						
Code	Description	Living Area	Floor Area	Eff Area	Unit Cost	Undeprec Value
BAS	First Floor	1,146	1,146	1,146	278.10	318,703
BMT	Basement Area	0	936	0	0.00	0
FOP	Open Porch	0	16	0	0.00	0
GAR	Attached Garage	0	302	0	0.00	0
TQS	Three Quarter Story	608	936	608	180.65	169,085
WDC	Wood Deck	0	350	0	0.00	0
Ttl Gross Liv / Lease Area		1,754	3,686	1,754		487,788



2.15.2018