

CURRENT OWNER				TOPO	UTILITIES	STRT / ROAD	LOCATION	CURRENT ASSESSMENT				
TEIXEIRA, ADOLFO & ASSIS, MARCI				1 Level	1 All Public	1 Paved		Description	Code	Assessed	Assessed	801 FY2025 BARNSTABLE, MA VISION
85 BRANT WAY								RESIDNTL	1010	468,800	468,800	
HYANNIS MA 02601							4	RES LAND	1010	151,900	151,900	
				SUPPLEMENTAL DATA				Total 620,700 620,700				
				Alt Prcl ID Split Zonin BID Parcel ResExpt Q #DL 1 LOT 14 #DL 2 GIS ID F_979178_2705191				Plan Ref. 402/84 Land Ct# #SR Life Estate PP STATU Assoc Pid#				

RECORD OF OWNERSHIP		BK-VOL/PAGE	SALE DATE	Q/U	V/I	SALE PRIC	VC	PREVIOUS ASSESSMENTS (HISTORY)								
TEIXEIRA, ADOLFO & ASSIS, MARCIA D	27426	0268	06-03-2013	Q	I	284,950	00	Year	Code	Assessed	Year	Code	Assessed	Year	Code	Assessed
FOX, SHIRLEY TR	16021	0026	12-03-2002	U	I	10	1A	2025	1010	468,800	2024	1010	438,200	2023	1010	388,200
FOX, LOUIS & SHIRLEY	9243	0257	06-15-1994	Q	I	140,000	00		1010	151,900		1010	151,900		1010	138,100
PENN, RICHARD A & JULIE	7898	0231	03-15-1992	U	I	1	1A	Total 620,700 Total 590,100 Total 526,300								
PENN, RICHARD A	6147	0225	02-15-1988	Q	I	15,000	00									

EXEMPTIONS				OTHER ASSESSMENTS				
Year	Code	Description	Amount	Code	Description	Number	Amount	Comm Int
Total			0.00					

ASSESSING NEIGHBORHOOD			
Nbhd	Nbhd Name	B	Tracing
0105			Batch HYAN

NOTES			
This signature acknowledges a visit by a Data Collector or Assessor			
APPRAISED VALUE SUMMARY			
Appraised Bldg. Value (Card)			425,500
Appraised Xf (B) Value (Bldg)			39,400
Appraised Ob (B) Value (Bldg)			3,900
Appraised Land Value (Bldg)			151,900
Special Land Value			0
Total Appraised Parcel Value			620,700
Valuation Method			C
Total Appraised Parcel Value			620,700

BUILDING PERMIT RECORD								VISIT / CHANGE HISTORY						
Permit Id	Issue Date	Type	Description	Amount	Insp Date	% Comp	Date Comp	Comments	Date	Id	Type	Is	Cd	Purpost/Result
BLDR-23-93	07-26-2023	804	Addn Alt-Res	28,500		100		replacing wall around tub area	04-22-2020	WD			FR	Field Review
76968	06-01-2004	WD	Wood Deck	7,000	04-21-2005	100	01-01-2005		12-15-2017	KM	02		03	Cycl Insp Comp
B30185	11-01-1986	DW	Dwelling	0	01-15-1988	100		HY 11/2 S	04-30-2014	JR	03		16	In Office Review
									04-21-2005	MF	02		02	Bldg Permit Completed
									06-13-2002	PT	01		00	Meas/Listed-Interior Acces
									07-15-1990	ML	01		00	Meas/Listed-Interior Acces

LAND LINE VALUATION SECTION																	
B	Use Code	Description	Zone	LA	Land Units	Unit Price	Size Adj	AC Disc	Site Index	Cond.	Nbhd.	Nbhd. Adj	Notes	Location Adjustmen	Adj Unit P	Land Value	
1	1010	Single Fam M-0	RC-	4	0.340 AC	176,344.00	2.53383	1.0000	5	1.00	0105	1.000		1.0000	446,820.4	151,900	
Total Card Land Units					0.34 AC	Parcel Total Land Area					0.34	Total Land Value					151,900

CONSTRUCTION DETAIL			CONSTRUCTION DETAIL (CONTINUED)		
Element	Cd	Description	Element	Cd	Description
Style	04	Cape Cod			
Model	01	Residential			
Grade:	C	Average			
Stories	1.75	1 3/4 Stories			
Exterior Wall 1	14	Wood Shingle			
Exterior Wall 2	11	Clapboard			
Roof Structure	03	Gable/Hip			
Roof Cover	03	Asph/F Gls/Cmp			
Interior Wall 1	05	Drywall			
Interior Wall 2					
Interior Floor 1	14	Carpet			
Interior Floor 2					
Heat Fuel	03	Gas			
Heat Type	04	Hot Air			
AC Type	03	Central			
Bedrooms	03	3 Bedrooms			
Full Baths	3				
Half Baths	0				
Extra Fixtures					
Total Rooms	6	6 Rooms			
Bath Style					
Kitchen Style					
Occupancy					
Sewer Occupan					
Accessory Apt					
Foundation Alt	01	Poured Conc.			
Rms Prts					
Bath Split	30	3 Full-0 Half			

CONDO DATA				
Parcel Id		C	Owne	0.0
Adjust Type	Code	Description	Factor%	
Condo Flr				
Condo Unit				

COST / MARKET VALUATION	
Building Value New	506,534
Year Built	1986
Effective Year Built	2003
Depreciation Code	A
Remodel Rating	
Year Remodeled	
Depreciation %	16
Functional Obsol	0
External Obsol	0
Trend Factor	1
Condition	
Condition %	
Percent Good	84
RCNLD	425,500
Dep % Ovr	
Dep Ovr Comment	
Misc Imp Ovr	
Misc Imp Ovr Comment	
Cost to Cure Ovr	
Cost to Cure Ovr Comment	

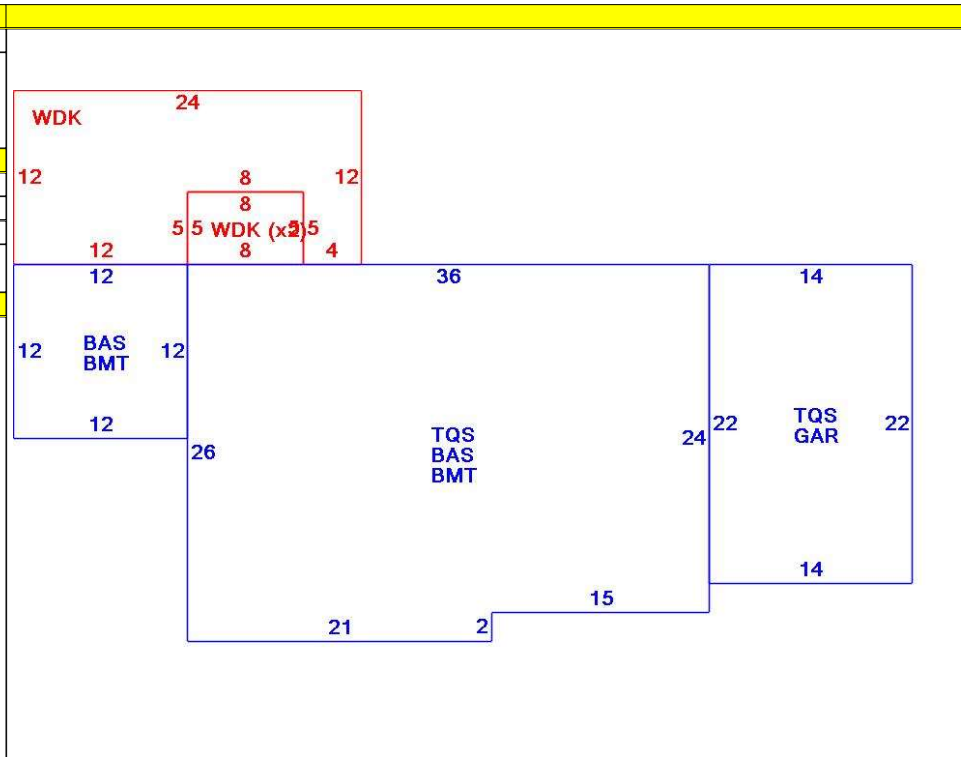

OB - OUTBUILDING & YARD ITEMS(L) / XF - BUILDING EXTRA FEATURES(B)										
Code	Description	L/B	Units	Unit Price	Yr Blt	Cond. Cd	% Gd	Grade	Grade Adj.	Appr. Value
FPL2	Fireplace 1.5 s	B	1	6000.00	2001		84		0.00	5,000
WDC	Wood Decking	L	328	20.00	1999		60		0.00	3,900
GAR	Attached Gara	B	308	40.00	2001		84		0.00	11,400
BMT	Basement-Unfi	B	1,050	26.01	2001		84		0.00	23,000

BUILDING SUB-AREA SUMMARY SECTION						
Code	Description	Living Area	Floor Area	Eff Area	Unit Cost	Undeprec Value
BAS	First Floor	1,050	1,050	1,050	275.44	289,212
BMT	Basement Area	0	1,050	0	0.00	0
GAR	Attached Garage	0	308	0	0.00	0
TQS	Three Quarter Story	789	1,214	789	179.01	217,322
WDK	Wood Deck	0	328	0	0.00	0
Ttl Gross Liv / Lease Area		1,839	3,950	1,839		506,534

