

CURRENT OWNER		TOPO	UTILITIES	STRT / ROAD	LOCATION	CURRENT ASSESSMENT				801 FY2025 BARNSTABLE, MA VISION	
LAZARESCU, CHRISTINE & LANG, F LANG TRUST 80 GREENVILLE DRIVE FORESTDALE MA 02644		1 Level	2 Public Water	1 Paved		Description	Code	Assessed	Assessed		
			4 Gas			RESIDNTL	1010	388,300	388,300		
			6 Septic		3	RES LAND	1010	178,900	178,900		
SUPPLEMENTAL DATA						Total				567,200	567,200
Alt Prcl ID		Split Zonin		Plan Ref.							
BID Parcel		ResExpt Q		Land Ct# 20239-C (SH 6)							
#DL 1 LOT 83		#DL 2		#SR							
GIS ID F_976949_2708280		Assoc Pid#		Life Estate							
				PP STATU							

RECORD OF OWNERSHIP		BK-VOL/PAGE	SALE DATE	Q/U	V/I	SALE PRIC	VC	PREVIOUS ASSESSMENTS (HISTORY)							
LAZARESCU, CHRISTINE & LANG, FRAN		C210172	0	07-19-2016	U	I	1	1F	Year	Code	Assessed	Year	Code	Assessed	
LANG, FRANCIS J & LAZARESCU-LANG,		C206564	0	06-18-2015	Q	I	295,000	00	2025	1010	388,300	2024	1010	380,100	
STARR, SAMUEL TR		C204759	0	10-24-2014	U	I	1	1A		1010	178,900		1010	178,900	
STARR, RHODA L		#D11041	0	01-08-2009	U	I	0	1							
STARR, ROBERT E & RHODA L		C161321	0	04-30-2001	U	I	100	1A							
Total										567,200		Total	559,000	Total	508,100

EXEMPTIONS			OTHER ASSESSMENTS				This signature acknowledges a visit by a Data Collector or Assessor				
Year	Code	Description	Amount	Code	Description	Number	Amount	Comm	Int		
Total			0.00								

ASSESSING NEIGHBORHOOD				APPRAISED VALUE SUMMARY				
Nbhd	Nbhd Name	B	Tracing	Batch				
0106				CENVIL				
NOTES				Appraised Bldg. Value (Card)				339,700
				Appraised Xf (B) Value (Bldg)				45,500
				Appraised Ob (B) Value (Bldg)				3,100
				Appraised Land Value (Bldg)				178,900
				Special Land Value				0
				Total Appraised Parcel Value				567,200
				Valuation Method				C
				Total Appraised Parcel Value				567,200

BUILDING PERMIT RECORD								VISIT / CHANGE HISTORY						
Permit Id	Issue Date	Type	Description	Amount	Insp Date	% Comp	Date Comp	Comments	Date	Id	Type	Is	Cd	Purpost/Result
201200465	01-25-2012	NR	New Roof	4,500	06-30-2012	100	06-30-2012	REROOF OVR 1 LAYER	04-21-2020	WD			FR	Field Review
									12-19-2017	SR	02		03	Cycl Insp Comp
									03-29-2016	AL	03		16	In Office Review
									03-29-2016	LH	03		16	In Office Review
									07-27-2015	AL	03		16	In Office Review
									12-17-2004	GB	01		00	Meas/Listed-Interior Acces
									12-17-2003	AM	01		00	Meas/Listed-Interior Acces

LAND LINE VALUATION SECTION																	
B	Use Code	Description	Zone	LA	Land Units	Unit Price	Size Adj	AC Disc	Site Index	Cond.	Nbhd.	Nbhd. Adj	Notes	Location Adjustmen	Adj Unit P	Land Value	
1	1010	Single Fam M-0	RD-	3	0.450	AC	176,344.00	1.95982	1.0000	5	1.00	0106	1.150		1.0006	397,444.1	178,900
Total Card Land Units					0.45	AC	Parcel Total Land Area					0.45	Total Land Value			178,900	

CONSTRUCTION DETAIL			CONSTRUCTION DETAIL (CONTINUED)		
Element	Cd	Description	Element	Cd	Description
Style	01	Ranch			
Model	01	Residential			
Grade:	C	Average			
Stories	1	1 Story			
Exterior Wall 1	14	Wood Shingle			
Exterior Wall 2					
Roof Structure	03	Gable/Hip			
Roof Cover	03	Asph/F Gls/Cmp			
Interior Wall 1	05	Drywall			
Interior Wall 2					
Interior Floor 1	14	Carpet			
Interior Floor 2					
Heat Fuel	03	Gas			
Heat Type	05	Hot Water			
AC Type	03	Central			
Bedrooms	03	3 Bedrooms			
Full Baths	2				
Half Baths	0				
Extra Fixtures					
Total Rooms	6	6 Rooms			
Bath Style					
Kitchen Style					
Occupancy					
Sewer Occupan					
Accessory Apt					
Foundation Alt	01	Poured Conc.			
Rms Prts					
Bath Split	20	2 Full-0 Half			

CONDO DATA			
Parcel Id		C	Owne 0.0
Adjust Type	Code	Description	Factor%
Condo Flr			
Condo Unit			

COST / MARKET VALUATION	
Building Value New	419,438
Year Built	1979
Effective Year Built	1999
Depreciation Code	A
Remodel Rating	
Year Remodeled	
Depreciation %	19
Functional Obsol	0
External Obsol	0
Trend Factor	1
Condition	
Condition %	
Percent Good	81
RCNLD	339,700
Dep % Ovr	
Dep Ovr Comment	
Misc Imp Ovr	
Misc Imp Ovr Comment	
Cost to Cure Ovr	
Cost to Cure Ovr Comment	

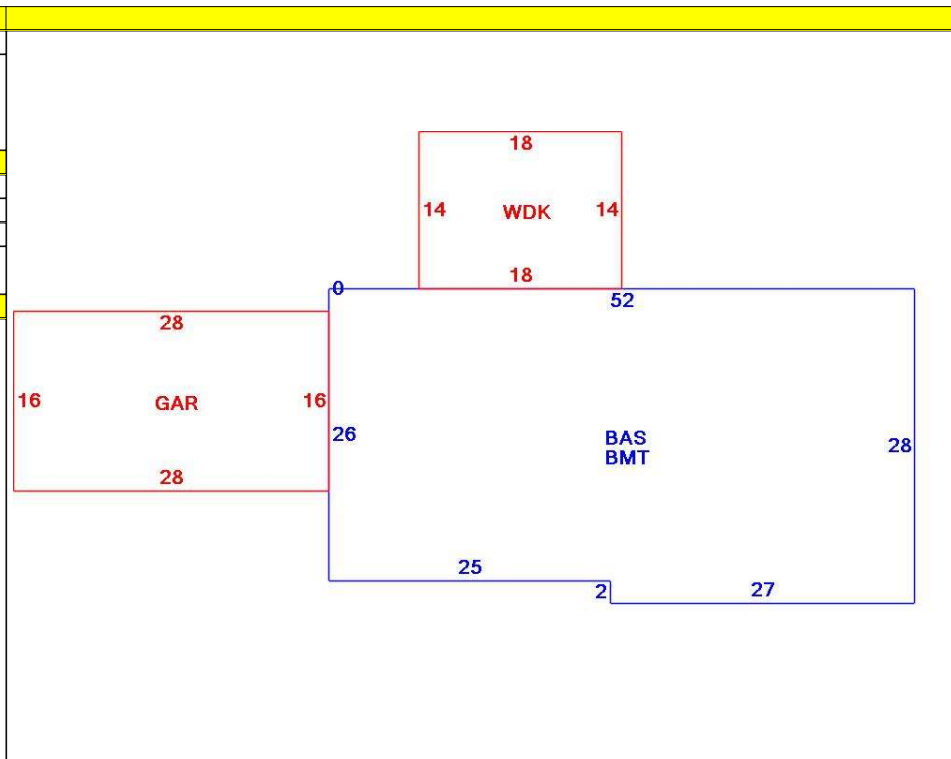

OB - OUTBUILDING & YARD ITEMS(L) / XF - BUILDING EXTRA FEATURES(B)										
Code	Description	L/B	Units	Unit Price	Yr Blt	Cond. Cd	% Gd	Grade	Grade Adj.	Appr. Value
FPL1	Fireplace 1 sto	B	1	5000.00	1997		81		0.00	4,100
WDC	Wood Decking	L	252	20.00	1998		58		0.00	3,100
GAR	Attached Gara	B	448	40.00	1997		81		0.00	14,000
BMT	Basement-Unfi	B	1,406	26.01	1997		81		0.00	27,400

BUILDING SUB-AREA SUMMARY SECTION						
Code	Description	Living Area	Floor Area	Eff Area	Unit Cost	Undeprec Value
BAS	First Floor	1,406	1,406	1,406	298.32	419,438
BMT	Basement Area	0	1,406	0	0.00	0
GAR	Attached Garage	0	448	0	0.00	0
WDK	Wood Deck	0	252	0	0.00	0
Ttl Gross Liv / Lease Area		1,406	3,512	1,406		419,438

