

CURRENT OWNER		TOPO	UTILITIES	STRT / ROAD	LOCATION	CURRENT ASSESSMENT			
COLBERT, ENRIQUE & JESSAMYN & ASKEW, ALAN & COLBERT, MARIA 85 MONTVIEW STREET WEST ROXBUR MA 02132		1 Level	6 Septic	1 Paved	1 Golf Course	Description	Code	Assessed	Assessed
			4 Gas			RESIDNTL	1090	653,700	653,700
			2 Public Water		4	RES LAND	1090	210,900	210,900
SUPPLEMENTAL DATA									
Alt Prcl ID Split Zonin BID Parcel ResExpt Q #DL 1 LOTS 13,15 & 17 #DL 2 GIS ID F_979733_2694861				Plan Ref. 92/123 Land Ct# #SR Life Estate PP STATU Assoc Pid#		Total		864,600	864,600

801
 FY2025
 BARNSTABLE, MA

VISION

RECORD OF OWNERSHIP		BK-VOL/PAGE	SALE DATE	Q/U	V/I	SALE PRIC	VC	PREVIOUS ASSESSMENTS (HISTORY)									
COLBERT, ENRIQUE & JESSAMYN & LOVERIDGE, JANET M & KLABOUCH, R LOVERIDGE, JANET M DUDDY, PHILLIP G TR JOSEFEK, PATRICIA A		25072 0037	12-09-2010	Q	I	429,000	00	Year	Code	Assessed	Year	Code	Assessed				
		11900 0043	12-09-1998	U	I	1	1A	2025	1090	653,700	2024	1090	608,400	2023	1090	516,900	
		10412 0105	09-30-1996	Q	I	197,500	U		1090	210,900		1090	210,900		1090	191,700	
		9046 0332	02-11-1994	U	I	165,000	L	Total									864,600
7091 0011	03-13-1990	U	I	1	A												

EXEMPTIONS			OTHER ASSESSMENTS					
Year	Code	Description	Amount	Code	Description	Number	Amount	Comm Int
Total			0.00					

This signature acknowledges a visit by a Data Collector or Assessor

ASSESSING NEIGHBORHOOD				
Nbhd	Nbhd Name	B	Tracing	Batch
0107				HYAN

APPRAISED VALUE SUMMARY	
Appraised Bldg. Value (Card)	619,500
Appraised Xf (B) Value (Bldg)	25,600
Appraised Ob (B) Value (Bldg)	8,600
Appraised Land Value (Bldg)	210,900
Special Land Value	0
Total Appraised Parcel Value	864,600
Valuation Method	C
Total Appraised Parcel Value	864,600

NOTES									
BUILDING PERMIT RECORD									
Permit Id	Issue Date	Type	Description	Amount	Insp Date	% Comp	Date Comp	Comments	
BLDR-23-14	12-27-2023	880	Alt-Int work-Res	40,000	04-24-2024	100	06-30-2024	Kitchen renovation and incorp	
EXPR-23-1	10-31-2023	835	Sid/Wind/Roof/	3,034	04-24-2024	100	06-30-2024	Air Sealing, Damming, Attic Ha	
26468	10-21-1997	AD	Addition	200	07-24-1998	100	06-30-1999	EXTEND WALL FOR GAS FP	
B29275	04-02-1986	AD	Addition	20,000	01-15-1987	100	06-30-1987	HP ADD'N-PORCH	

VISIT / CHANGE HISTORY									
Date	Id	Type	Is	Cd	Purpost/Result				
06-30-2024	SR	02		02	Bldg Permit Completed				
05-21-2020	WD			FR	Field Review				
02-07-2020	CK	22		22	Change of Address				
01-30-2013	RB	03		03	Cycl Insp Comp				

LAND LINE VALUATION SECTION																	
B	Use Code	Description	Zone	LA	Land Units	Unit Price	Size Adj	AC Disc	Site Index	Cond.	Nbhd.	Nbhd. Adj	Notes	Location Adjustmen	Adj Unit P	Land Value	
1	1090	Multi Hses M-01	RF-1	4	0.300	AC	176,344.00	2.84692	1.0000	5	1.00	0107	1.400		1.0000	702,854.2	210,900
Total Card Land Units					0.30	AC	Parcel Total Land Area					0.30	Total Land Value			210,900	

CONSTRUCTION DETAIL			CONSTRUCTION DETAIL (CONTINUED)		
Element	Cd	Description	Element	Cd	Description
Style	03	Colonial			
Model	01	Residential			
Grade:	C	Average			
Stories	2	2 Stories			
Exterior Wall 1	11	Clapboard			
Exterior Wall 2					
RooF Structure	03	Gable/Hip			
RooF Cover	03	Asph/F Gls/Cmp			
Interior Wall 1	05	Drywall			
Interior Wall 2					
Interior Floor 1	12	Hardwood			
Interior Floor 2					
Heat Fuel	03	Gas			
Heat Type	05	Hot Water			
AC Type	03	Central			
Bedrooms	04	4 Bedrooms			
Full Baths	3				
Half Baths	0				
Extra Fixtures					
Total Rooms	8	8 Rooms			
Bath Style					
Kitchen Style					
Occupancy					
Sewer Occupan	2				
Accessory Apt					
Foundation Alt	02	Conc. Block			
Rms Prts					
Bath Split	30	3 Full-0 Half			

CONDO DATA

Parcel Id		C		Owne	0.0
Adjust Type	Code	Description	Factor%		
Condo Flr					
Condo Unit					

COST / MARKET VALUATION

Building Value New	462,113
Year Built	1968
Effective Year Built	1999
Depreciation Code	G
Remodel Rating	
Year Remodeled	
Depreciation %	19
Functional Obsol	0
External Obsol	0
Trend Factor	1
Condition	
Condition %	
Percent Good	81
RCNLD	374,300
Dep % Ovr	
Dep Ovr Comment	
Misc Imp Ovr	
Misc Imp Ovr Comment	
Cost to Cure Ovr	
Cost to Cure Ovr Comment	

OB - OUTBUILDING & YARD ITEMS(L) / XF - BUILDING EXTRA FEATURES(B)

Code	Description	L/B	Units	Unit Price	Yr Blt	Cond. Cd	% Gd	Grade	Grade Adj.	Appr. Value
FPLG	Gas Fireplace-	B	1	2500.00	1997		81		0.00	2,000
WDC	Wood Decking	L	408	20.00	2010		82		0.00	6,400
BMT	Basement-Unfi	B	904	26.01	1997		81		0.00	20,100

BUILDING SUB-AREA SUMMARY SECTION

Code	Description	Living Area	Floor Area	Eff Area	Unit Cost	Undeprec Value
BAS	First Floor	1,261	1,261	1,261	269.14	339,386
BMT	Basement Area	0	904	0	0.00	0
FUS	Upper Story	456	456	456	269.14	122,728
WDK	Wood Deck	0	408	0	0.00	0
Ttl Gross Liv / Lease Area		1,717	3,029	1,717		462,114

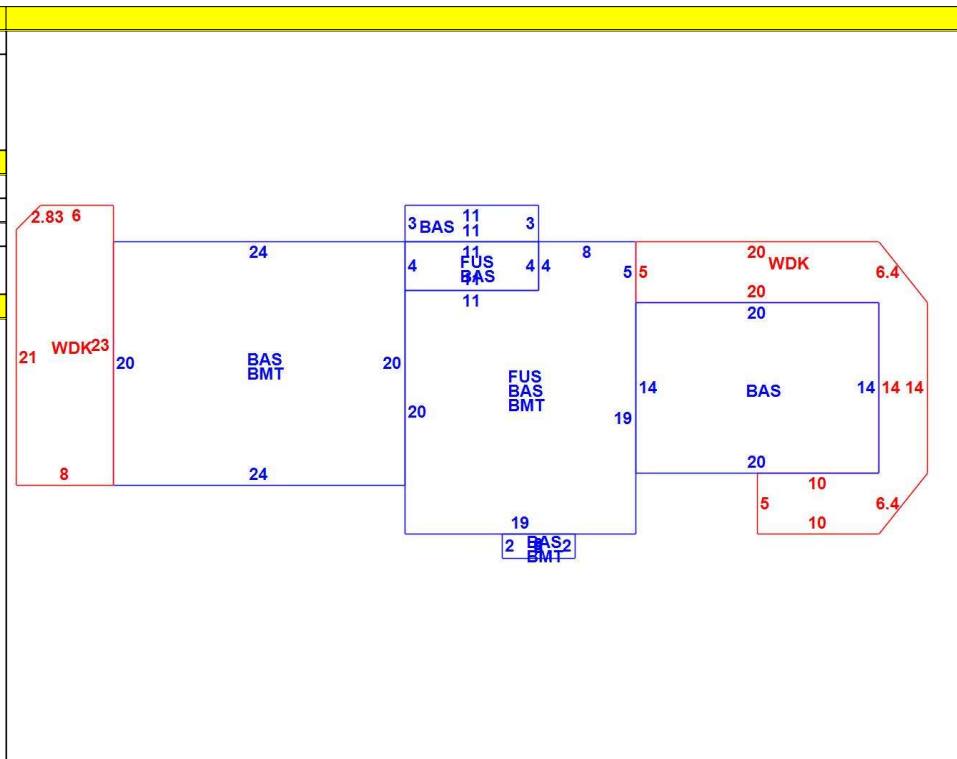

CURRENT OWNER		TOPO	UTILITIES	STRT / ROAD	LOCATION	CURRENT ASSESSMENT			
COLBERT, ENRIQUE & JESSAMYN & ASKEW, ALAN & COLBERT, MARIA 85 MONTVIEW STREET WEST ROXBUR MA 02132		1 Level	6 Septic	1 Paved	1 Golf Course	Description	Code	Assessed	Assessed
			4 Gas			RESIDNTL	1090	653,700	653,700
			2 Public Water		4	RES LAND	1090	210,900	210,900
SUPPLEMENTAL DATA									
Alt Prcl ID Split Zonin BID Parcel ResExpt Q #DL 1 LOTS 13,15 & 17 #DL 2 GIS ID F_979733_2694861				Plan Ref. 92/123 Land Ct# #SR Life Estate PP STATU Assoc Pid#		Total 864,600 864,600			

801
 FY2025
 BARNSTABLE, MA

VISION

RECORD OF OWNERSHIP		BK-VOL/PAGE	SALE DATE	Q/U	V/I	SALE PRIC	VC	PREVIOUS ASSESSMENTS (HISTORY)					
COLBERT, ENRIQUE & JESSAMYN & LOVERIDGE, JANET M & KLABOUCH, R LOVERIDGE, JANET M DUDDY, PHILLIP G TR JOSEFEK, PATRICIA A		25072 0037	12-09-2010	Q	I	429,000	00	Year	Code	Assessed	Year	Code	Assessed
		11900 0043	12-09-1998	U	I	1	1A	2025	1090	653,700	2024	1090	608,400
		10412 0105	09-30-1996	Q	I	197,500	U		1090	210,900		1090	210,900
		9046 0332	02-11-1994	U	I	165,000	L	Total 864,600 Total 819,300 Total 708,600					
7091 0011	03-13-1990	U	I	1	A								

EXEMPTIONS			OTHER ASSESSMENTS					
Year	Code	Description	Amount	Code	Description	Number	Amount	Comm Int
		Total	0.00					

This signature acknowledges a visit by a Data Collector or Assessor

ASSESSING NEIGHBORHOOD				APPRAISED VALUE SUMMARY	
Nbhd	Nbhd Name	B	Tracing	Batch	
0107				HYAN	
NOTES					Appraised Bldg. Value (Card) 619,500
					Appraised Xf (B) Value (Bldg) 25,600
					Appraised Ob (B) Value (Bldg) 8,600
					Appraised Land Value (Bldg) 210,900
					Special Land Value 0
					Total Appraised Parcel Value 864,600
					Valuation Method C
					Total Appraised Parcel Value 864,600

BUILDING PERMIT RECORD							VISIT / CHANGE HISTORY							
Permit Id	Issue Date	Type	Description	Amount	Insp Date	% Comp	Date Comp	Comments	Date	Id	Type	Is	Cd	Purpost/Result
									08-22-2023	WT	02		03	Cycl Insp Comp

LAND LINE VALUATION SECTION																	
B	Use Code	Description	Zone	LA	Land Units	Unit Price	Size Adj	AC Disc	Site Index	Cond.	Nbhd.	Nbhd. Adj	Notes	Location Adjustmen	Adj Unit P	Land Value	
2	1090	Multi Hses M-01	RF-1	4	0 SF	0.00	1.00000	1.0000	5	1.00	0107	1.400		0.0000	0	0	
Total Card Land Units					0.00	SF	Parcel Total Land Area					0.30	Total Land Value				0

