

CURRENT OWNER		TOPO	UTILITIES	STRT / ROAD	LOCATION	CURRENT ASSESSMENT					
GOLDBERG, BRETT M & JUDITH G T BRETT M & JUDITH G GOLDBERG R 32 BANKS STREET SOMERVILLE MA 02114					1 Lake/Pond Fro	Description	Code	Assessed	Assessed		
					1 Excel View	RESIDNTL	1010	417,300	417,300		
					6	RES LAND	1010	243,200	243,200		
SUPPLEMENTAL DATA											
Alt Prcl ID Split Zonin BID Parcel ResExpt Q #DL 1 LOT 21 #DL 2 GIS ID F_943794_2707231					Plan Ref. 249/79 Land Ct# #SR Life Estate PP STATU Assoc Pid#		Total			660,500	660,500

801
 FY2025
 BARNSTABLE, MA

VISION

RECORD OF OWNERSHIP		BK-VOL/PAGE	SALE DATE	Q/U	V/I	SALE PRIC	VC	PREVIOUS ASSESSMENTS (HISTORY)									
GOLDBERG, BRETT M & JUDITH G TRS		35483 166	11-14-2022	U	I	1	1F	Year	Code	Assessed	Year	Code	Assessed	Year	Code	Assessed	
GOLDBERG, BRETT & JUDITH G		31525 0191	09-13-2018	U	I	230,000	1A	2025	1010	417,300	2024	1010	425,700	2023	1010	333,100	
GOLDENBERG, BARRY N TR		30738 0157	08-31-2017	U	I	0	1F		1010	243,200		1010	243,200		1010	221,100	
GOLDENBERG, ELAINE D TR		26997 0250	12-28-2012	U	I	1	1F										
GOLDENBERG, ELAINE D		26997 0247	12-28-2012	U	I	1	1F										
Total								660,500		Total		668,900		Total		554,200	

EXEMPTIONS			OTHER ASSESSMENTS					
Year	Code	Description	Amount	Code	Description	Number	Amount	Comm Int
								This signature acknowledges a visit by a Data Collector or Assessor
Total			0.00					

ASSESSING NEIGHBORHOOD				APPRAISED VALUE SUMMARY			
Nbhd	Nbhd Name	B	Tracing	Batch			
0107				MARSTM			
NOTES				Appraised Bldg. Value (Card) 368,100 Appraised Xf (B) Value (Bldg) 37,900 Appraised Ob (B) Value (Bldg) 11,300 Appraised Land Value (Bldg) 243,200 Special Land Value 0 Total Appraised Parcel Value 660,500 Valuation Method C Total Appraised Parcel Value 660,500			

BUILDING PERMIT RECORD									VISIT / CHANGE HISTORY					
Permit Id	Issue Date	Type	Description	Amount	Insp Date	% Comp	Date Comp	Comments	Date	Id	Type	Is	Cd	Purpost/Result
B19481	08-01-1977	DW	Dwelling	0	01-15-1978	100	01-15-1978	MM 1 1/2S	11-30-2022	DB	02		03	Cycl Insp Comp
									05-19-2020	LS			FR	Field Review
									02-15-2018	MD	22		22	Change of Address
									09-29-2014	SR	02		03	Cycl Insp Comp
									05-17-2005	PT	02		01	Meas/Est

LAND LINE VALUATION SECTION																	
B	Use Code	Description	Zone	LA	Land Units	Unit Price	Size Adj	AC Disc	Site Index	Cond.	Nbhd.	Nbhd. Adj	Notes	Location Adjustmen	Adj Unit P	Land Value	
1	1010	Single Fam M-0	RF	3	0.840 AC	176,344.00	1.17279	1.0000	5	1.00	0107	1.400	LONG POND		1.0000	289,539.2	
Total Card Land Units					0.84	AC	Parcel Total Land Area					0.84	Total Land Value				243,200

CONSTRUCTION DETAIL			CONSTRUCTION DETAIL (CONTINUED)		
Element	Cd	Description	Element	Cd	Description
Style	07	Modern/Contemp			
Model	01	Residential			
Grade:	C+	Average Plus			
Stories	2	2 Stories			
Exterior Wall 1	14	Wood Shingle			
Exterior Wall 2					
Roof Structure	03	Gable/Hip			
Roof Cover	03	Asph/F Gls/Cmp			
Interior Wall 1	05	Drywall			
Interior Wall 2					
Interior Floor 1	14	Carpet			
Interior Floor 2					
Heat Fuel	03	Gas			
Heat Type	04	Hot Air			
AC Type	03	Central			
Bedrooms	03	3 Bedrooms			
Full Baths	3				
Half Baths	0				
Extra Fixtures					
Total Rooms	7	7 Rooms			
Bath Style					
Kitchen Style					
Occupancy					
Sewer Occupan					
Accessory Apt					
Foundation Alt	01	Poured Conc.			
Rms Prts					
Bath Split	30	3 Full-0 Half			
			CONDO DATA		
			Parcel Id	C	Owne 0.0
			Adjust Type Code Description Factor%		
			Condo Flr		
			Condo Unit		
			COST / MARKET VALUATION		
			Building Value New		438,213
			Year Built		1977
			Effective Year Built		2003
			Depreciation Code		G
			Remodel Rating		
			Year Remodeled		
			Depreciation %		16
			Functional Obsol		0
			External Obsol		0
			Trend Factor		1
			Condition		
			Condition %		
			Percent Good		84
			RCNLD		368,100
			Dep % Ovr		
			Dep Ovr Comment		
			Misc Imp Ovr		
			Misc Imp Ovr Comment		
			Cost to Cure Ovr		
			Cost to Cure Ovr Comment		

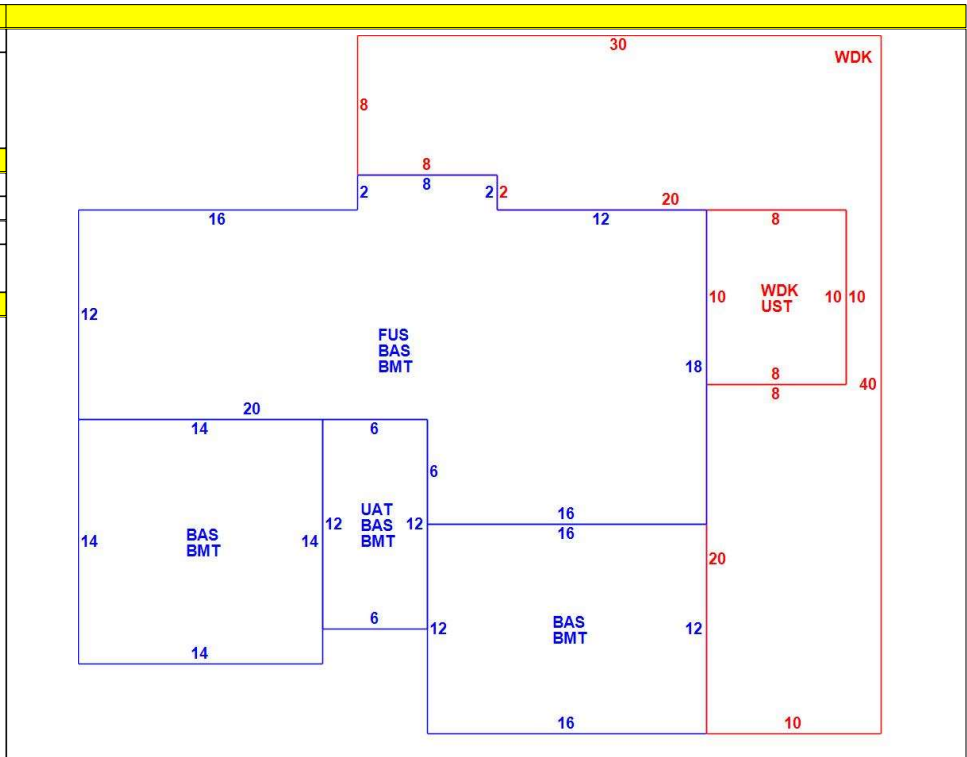

OB - OUTBUILDING & YARD ITEMS(L) / XF - BUILDING EXTRA FEATURES(B)										
Code	Description	L/B	Units	Unit Price	Yr Blt	Cond. Cd	% Gd	Grade	Grade Adj.	Appr. Value
FPLG	Gas Fireplace-	B	1	2500.00	2001		84		0.00	2,100
BFA	Bsmt Fin-Avg	B	850	17.36	2001		84		0.00	12,400
WDC	Wood Decking	L	584	20.00	2002		66		0.00	7,100
UST	Utility Storage-	B	80	17.11	2001		84		0.00	1,000
BMT	Basement-Unfi	B	1,004	26.01	2001		84		0.00	22,400
DKPL	Pond Dock-Lig	L	1	4200.00	2020		100		0.00	4,200

BUILDING SUB-AREA SUMMARY SECTION							
Code	Description	Living Area	Floor Area	Eff Area	Unit Cost	Undeprec Value	
BAS	First Floor	1,004	1,004	1,004	281.81	282,936	
BMT	Basement Area	0	1,004	0	0.00	0	
FUS	Upper Story	544	544	544	281.81	153,304	
UAT	Attic, Unfinished	0	72	7	27.40	1,973	
UST	Utility Enclosure	0	80	0	0.00	0	
WDK	Wood Deck	0	584	0	0.00	0	
Ttl Gross Liv / Lease Area		1,548	3,288	1,555		438,213	