

CONSTRUCTION DETAIL			CONSTRUCTION DETAIL (CONTINUED)		
Element	Cd	Description	Element	Cd	Description
Style	01	Ranch			
Model	01	Residential			
Grade:	C	Average			
Stories	1	1 Story			
Exterior Wall 1	14	Wood Shingle			
Exterior Wall 2	11	Clapboard			
RooF Structure	03	Gable/Hip			
RooF Cover	03	Asph/F Gls/Cmp			
Interior Wall 1	05	Drywall			
Interior Wall 2					
Interior Floor 1	12	Hardwood			
Interior Floor 2					
Heat Fuel	03	Gas			
Heat Type	04	Hot Air			
AC Type	03	Central			
Bedrooms	03	3 Bedrooms			
Full Baths	2				
Half Baths	0				
Extra Fixtures					
Total Rooms	6	6 Rooms			
Bath Style					
Kitchen Style					
Occupancy					
Sewer Occupan					
Accessory Apt					
Foundation Alt	01	Poured Conc.			
Rms Prts					
Bath Split	20	2 Full-0 Half			

CONDO DATA			
Parcel Id		C	Ownr 0.0
		B	S
Adjust Type	Code	Description	Factor%
Condo Flr			
Condo Unit			

COST / MARKET VALUATION	
Building Value New	378,738
Year Built	1968
Effective Year Built	1994
Depreciation Code	A
Remodel Rating	
Year Remodeled	
Depreciation %	23
Functional Obsol	0
External Obsol	0
Trend Factor	1
Condition	
Condition %	
Percent Good	77
RCNLD	291,600
Dep % Ovr	
Dep Ovr Comment	
Misc Imp Ovr	
Misc Imp Ovr Comment	
Cost to Cure Ovr	
Cost to Cure Ovr Comment	

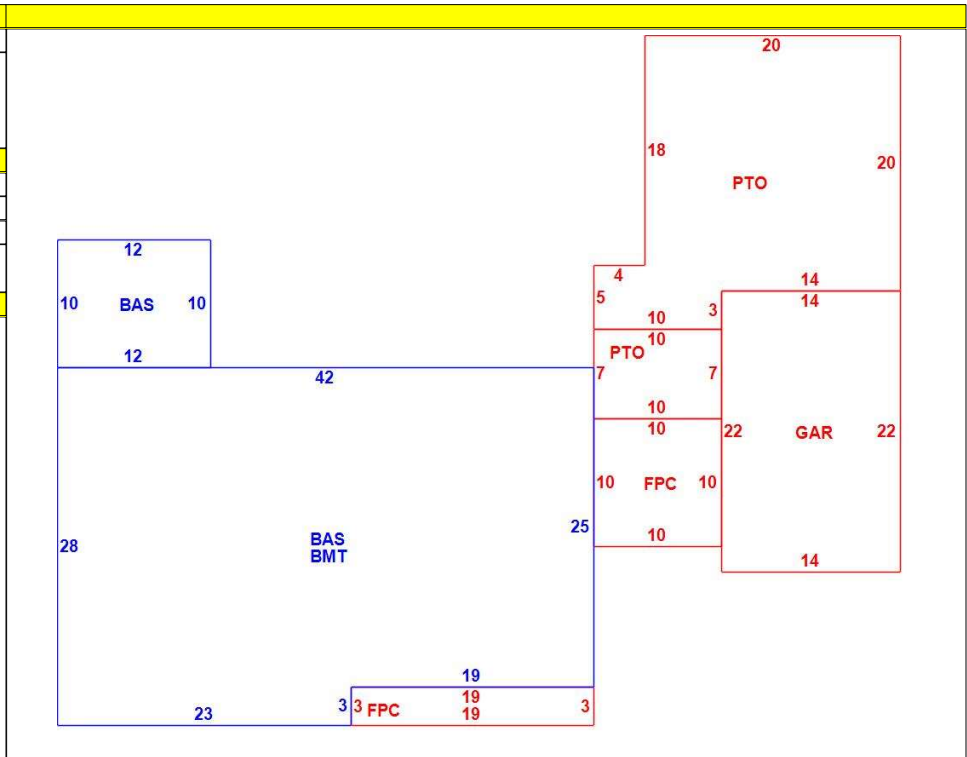

OB - OUTBUILDING & YARD ITEMS(L) / XF - BUILDING EXTRA FEATURES(B)										
Code	Description	L/B	Units	Unit Price	Yr Blt	Cond. Cd	% Gd	Grade	Grade Adj.	Appr. Value
FPL1	Fireplace 1 sto	B	1	5000.00	1992		77		0.00	3,900
FOPC	Open Prch-roo	B	157	55.00	1992		77		0.00	4,800
GAR	Attached Gara	B	308	40.00	1992		77		0.00	10,500
BMT	Basement-Unfi	B	1,119	26.01	1992		77		0.00	22,000
PATS	Patio-Concrete	L	438	20.00	2015		96		0.00	8,200
PAT2	Patio-Good	L	70	9.94	2015		96		0.00	800

BUILDING SUB-AREA SUMMARY SECTION						
Code	Description	Living Area	Floor Area	Eff Area	Unit Cost	Undeprec Value
BAS	First Floor	1,239	1,239	1,239	305.68	378,738
BMT	Basement Area	0	1,119	0	0.00	0
FPC	Open Porch Conc. Floor	0	157	0	0.00	0
GAR	Attached Garage	0	308	0	0.00	0
PTO	Patio	0	508	0	0.00	0
Ttl Gross Liv / Lease Area		1,239	3,331	1,239		378,738

