

CONSTRUCTION DETAIL			CONSTRUCTION DETAIL (CONTINUED)		
Element	Cd	Description	Element	Cd	Description
Style	03	Colonial			
Model	01	Residential			
Grade:	C+	Average Plus			
Stories	2	2 Stories			
Exterior Wall 1	14	Wood Shingle			
Exterior Wall 2	25	Vinyl Siding			
RooF Structure	03	Gable/Hip			
RooF Cover	03	Asph/F Gls/Cmp			
Interior Wall 1	05	Drywall			
Interior Wall 2					
Interior Floor 1	14	Carpet			
Interior Floor 2					
Heat Fuel	03	Gas			
Heat Type	04	Hot Air			
AC Type	03	Central			
Bedrooms	05	5 Bedrooms			
Full Baths	4				
Half Baths	0				
Extra Fixtures					
Total Rooms					
Bath Style					
Kitchen Style					
Occupancy					
Sewer Occupan					
Accessory Apt	Y	Apt here			
Foundation Alt	01	Poured Conc.			
Rms Prts					
Bath Split	40	4 Full-0 Half			

CONDO DATA				
Parcel Id	C	Ownr	0.0	
			B	S
Adjust Type	Code	Description	Factor%	
Condo Flr				
Condo Unit				

COST / MARKET VALUATION		
Building Value New		817,879
Year Built		1987
Effective Year Built		2003
Depreciation Code		A
Remodel Rating		
Year Remodeled		
Depreciation %		16
Functional Obsol		0
External Obsol		0
Trend Factor		1
Condition		
Condition %		
Percent Good		84
RCNLD		687,000
Dep % Ovr		
Dep Ovr Comment		
Misc Imp Ovr		
Misc Imp Ovr Comment		
Cost to Cure Ovr		
Cost to Cure Ovr Comment		

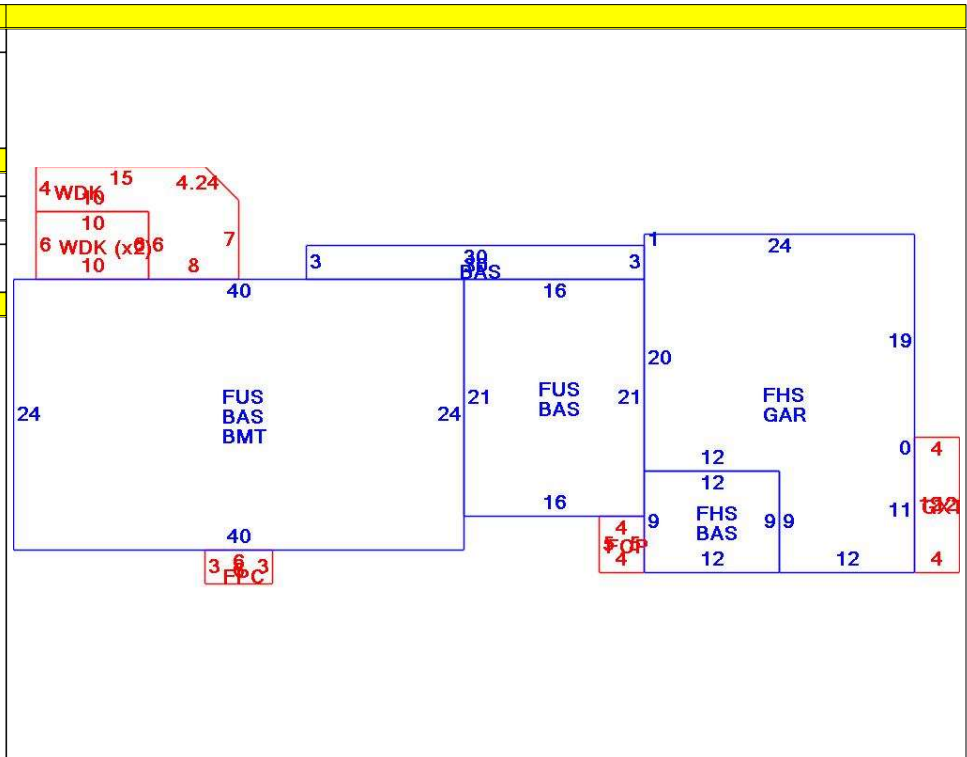

OB - OUTBUILDING & YARD ITEMS(L) / XF - BUILDING EXTRA FEATURES(B)										
Code	Description	L/B	Units	Unit Price	Yr Blt	Cond. Cd	% Gd	Grade	Grade Adj.	Appr. Value
FPL3	Fireplace 2 sto	B	1	7000.00	2001		84		0.00	5,900
BFA1	Bsmt Fin-Goo	B	324	32.56	2001		84		0.00	8,900
WDC	Wood Decking	L	236	20.00	2000		62		0.00	3,200
GAR	Attached Gara	B	612	40.00	2001		84		0.00	17,900
BMT	Basement-Unfi	B	960	26.01	2001		84		0.00	21,700
GXT	Garage Extens	B	48	65.00	2001		84		0.00	2,600
FOP	Open Porch-ro	B	20	55.00	2001		84		0.00	1,500
FOPC	Open Prch-roo	B	18	55.00	2001		84		0.00	1,200
SHD2	Shed w/Elec	L	144	26.00	2008		78		0.00	2,900
SOL2	Solar PV Pane	B	49	725.00	2001		0		0.00	0

BUILDING SUB-AREA SUMMARY SECTION						
Code	Description	Living Area	Floor Area	Eff Area	Unit Cost	Undeprec Value
BAS	First Floor	1,494	1,494	1,494	259.64	387,908
BMT	Basement Area	0	960	0	0.00	0
FHS	Half Story	360	720	360	129.82	93,472
FOP	Open Porch	0	20	0	0.00	0
FOPC	Open Porch Conc. Floor	0	18	0	0.00	0
FUS	Upper Story	1,296	1,296	1,296	259.64	336,499
GAR	Attached Garage	0	612	0	0.00	0
GXT	Gar Extension-Front	0	48	0	0.00	0
WDK	Wood Deck	0	236	0	0.00	0
Ttl Gross Liv / Lease Area		3,150	5,404	3,150		817,879

