

CONSTRUCTION DETAIL			CONSTRUCTION DETAIL (CONTINUED)		
Element	Cd	Description	Element	Cd	Description
Style	55	Condominium			
Model	05	Res Condo			
Grade	C	Average			
Stories	1.75	1 3/4 Stories			
Occupancy	0				
Interior Wall 1	05	Drywall			
Interior Wall 2					
Interior Floor 1	14	Carpet			
Interior Floor 2					
Heat Fuel	04	Electric			
Heat Type	07	Elec Baseboard			
AC Type	01	None			
Bedrooms	03	3 Bedrooms			
Full Baths	2	2 Full			
Half Baths	0				
Extra Fixtures					
Total Rooms	5	5 Rooms			
Bath Style					
Kitchen Style					
Master Deed L	1380				
Bath Split	20	2 Full-0 Half			
Foundation	01	Poured Conc.			
AC Type Alt					
Sewer Occupan					
CONDO DATA					
Parcel Id	104288	C 0760	Owne	2.3	
	SEA MEADOW VIL	B 1	S 1		
Adjust Type	Code	Description	Factor%		
Condo Flr	MFE	MULTI FL END	100		
Condo Unit	MKT0	MKT0	100		
COST / MARKET VALUATION					
Building Value New			390,008		
Year Built			1988		
Effective Year Built			2007		
Depreciation Code			A		
Remodel Rating					
Year Remodeled					
Depreciation %			13		
Functional Obsol			0		
External Obsol			0		
Trend Factor			1		
Condition					
Condition %					
Percent Good			87		
Cns Sect Rcnld			339,300		
Dep % Ovr					
Dep Ovr Comment					
Misc Imp Ovr					
Misc Imp Ovr Comment					
Cost to Cure Ovr					
Cost to Cure Ovr Comment					

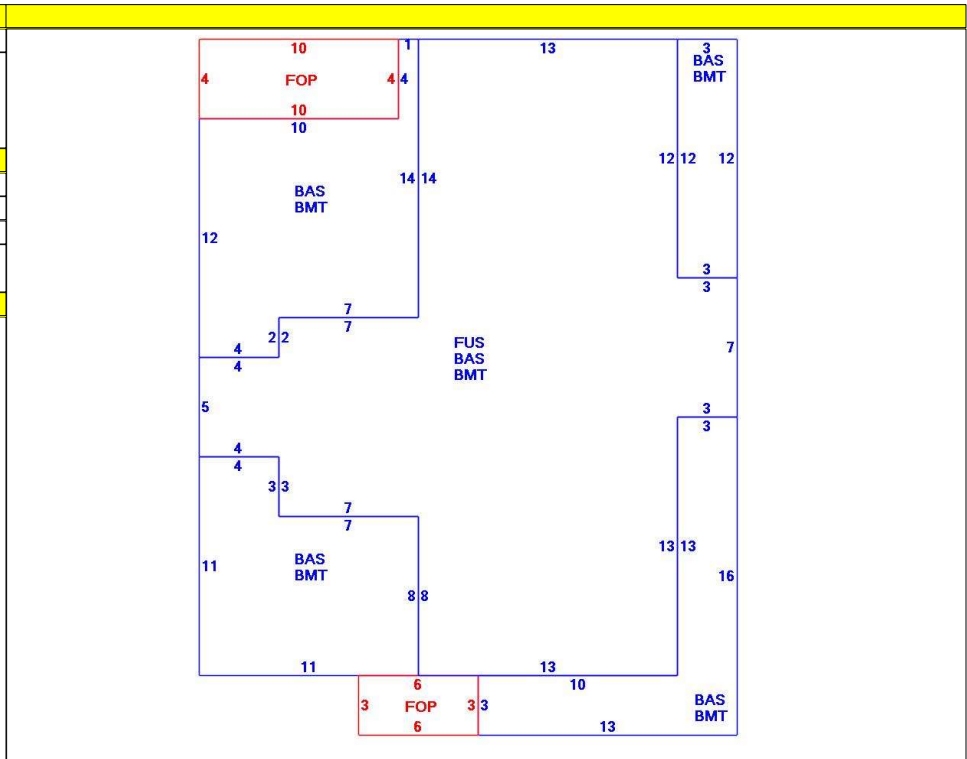

OB - OUTBUILDING & YARD ITEMS(L) / XF - BUILDING EXTRA FEATURES(B)										
Code	Description	L/B	Units	Unit Price	Yr Blt	Cond. Cd	% Gd	Grade	Grade Adj.	Appr. Value
BMT	Basement-Unfi	B	863	26.01	2005		87		0.00	20,800
FOP	Open Porch-ro	B	58	55.00	2005		87		0.00	3,300

BUILDING SUB-AREA SUMMARY SECTION						
Code	Description	Living Area	Floor Area	Eff Area	Unit Cost	Undeprec Value
BAS	First Floor	863	863	863	280.58	242,141
BMT	Basement Area	0	863	0	0.00	0
FOP	Open Porch	0	58	0	0.00	0
FUS	Upper Story	527	527	527	280.58	147,866
Ttl Gross Liv / Lease Area		1,390	2,311	1,390		390,007

