

CURRENT OWNER		TOPO	UTILITIES	STRT / ROAD	LOCATION	CURRENT ASSESSMENT														
BARNSTABLE HOUSING AUTHORITY  146 SOUTH STREET  HYANNIS MA 02601						Description		Code	Assessed		Assessed		801  FY2025 BARNSTABLE, MA  <b>VISION</b>							
						EXEMPT		9700	277,900		277,900									
<b>SUPPLEMENTAL DATA</b>						4 Hyannis CU		Total		277,900		277,900								
Alt Prcl ID		Split Zonin		Plan Ref. 447/55,59		Land Ct#														
#DL 1		UNIT 49		Life Estate		PP STATU														
#DL 2		BLDG F		Assoc Pid#																
GIS ID		F_981842_2703782																		
RECORD OF OWNERSHIP				BK-VOL/PAGE	SALE DATE	Q/U	V/I	SALE PRICE	VC	PREVIOUS ASSESSMENTS (HISTORY)										
BARNSTABLE HOUSING AUTHORITY				6337	0074	07-15-1988	Q	I	95,000	U	Year	Code	Assessed	Year	Code	Assessed V	Year	Code	Assessed	
SEA MEADOW VILLAGE ASSOC				6232	0003	04-15-1988	U	I	1	B	2025	9700	277,900	2024	9700	239,600	2023	9700	228,700	
Total										Total		277,900		Total		239,600		Total		228,700
EXEMPTIONS				OTHER ASSESSMENTS						This signature acknowledges a visit by a Data Collector or Assessor										
Year	Code	Description		Amount		Code	Description	Number	Amount	Comm Int										
Total				0.00								<b>APPRAISED VALUE SUMMARY</b>								
Nbhd				Nbhd Name		B		Tracing		Batch		Appraised Bldg. Value (Card) 266,100								
0001								HYAN		Appraised Xf (B) Value (Bldg) 8,700										
										Appraised Ob (B) Value (Bldg) 3,100										
										Appraised Land Value (Bldg) 0										
										Special Land Value 0										
										Total Appraised Parcel Value 277,900										
										Valuation Method C										
										Total Appraised Parcel Value 277,900										
BUILDING PERMIT RECORD										VISIT / CHANGE HISTORY										
Permit Id	Issue Date	Type	Description	Amount	Insp Date	% Comp	Date Comp	Comments		Date	Id	Type	Is	Cd	Purpost/Result					
										05-14-2020	GM	04		FR	Field Review					
										12-11-2018	SR	02		03	Cycl Insp Comp					
										09-16-2013	TP	03		16	In Office Review					
										06-15-2004	PT	02		01	Meas/Est					
LAND LINE VALUATION SECTION																				
B	Use Code	Description	Zone	Dist	Land Type	Land Units	Unit Price	Size Adj	Site Index	Cond.	Nbhd.	Nbhd. Adj	Notes	Location Adjustmen	Adj Unit P	Land Value				
1	970U	Hsng Auth M-05	RB	4	Hyannis	0 SF	0.00	1.00000	5	1.00	0001	1.000			0.0000	0				
Total Card Land Units						0 SF	Parcel Total Land Area						0.00	Total Land Value				0		

CONSTRUCTION DETAIL			CONSTRUCTION DETAIL (CONTINUED)		
Element	Cd	Description	Element	Cd	Description
Style	55	Condominium			
Model	05	Res Condo			
Grade	C	Average			
Stories	1	1 Story			
Occupancy	0				
Interior Wall 1	05	Drywall			
Interior Wall 2					
Interior Floor 1	14	Carpet			
Interior Floor 2					
Heat Fuel	04	Electric			
Heat Type	07	Elec Baseboard			
AC Type	01	None			
Bedrooms	02	2 Bedrooms			
Full Baths	1	1 Full			
Half Baths	0				
Extra Fixtures					
Total Rooms	4	4 Rooms			
Bath Style					
Kitchen Style					
Master Deed L	1020	1 Full-0 Half			
Bath Split	10	Mixed			
Foundation	08				
AC Type Alt					
Sewer Occupan					
<b>CONDO DATA</b>					
Parcel Id	104288	C 0760	Owne	1.6	
	SEA MEADOW VIL	B 1	S 1		
Adjust Type	Code	Description	Factor%		
Condo Flr	1FE	FIRST FL END	100		
Condo Unit	MKT0	MKT0	100		
<b>COST / MARKET VALUATION</b>					
Building Value New		305,841			
Year Built		1988			
Effective Year Built		2007			
Depreciation Code		A			
Remodel Rating					
Year Remodeled		13			
Depreciation %		0			
Functional Obsol		0			
External Obsol		0			
Trend Factor		1			
Condition					
Condition %		87			
Percent Good		266,100			
Cns Sect Rcnld					
Dep % Ovr					
Dep Ovr Comment					
Misc Imp Ovr					
Misc Imp Ovr Comment					
Cost to Cure Ovr					
Cost to Cure Ovr Comment					

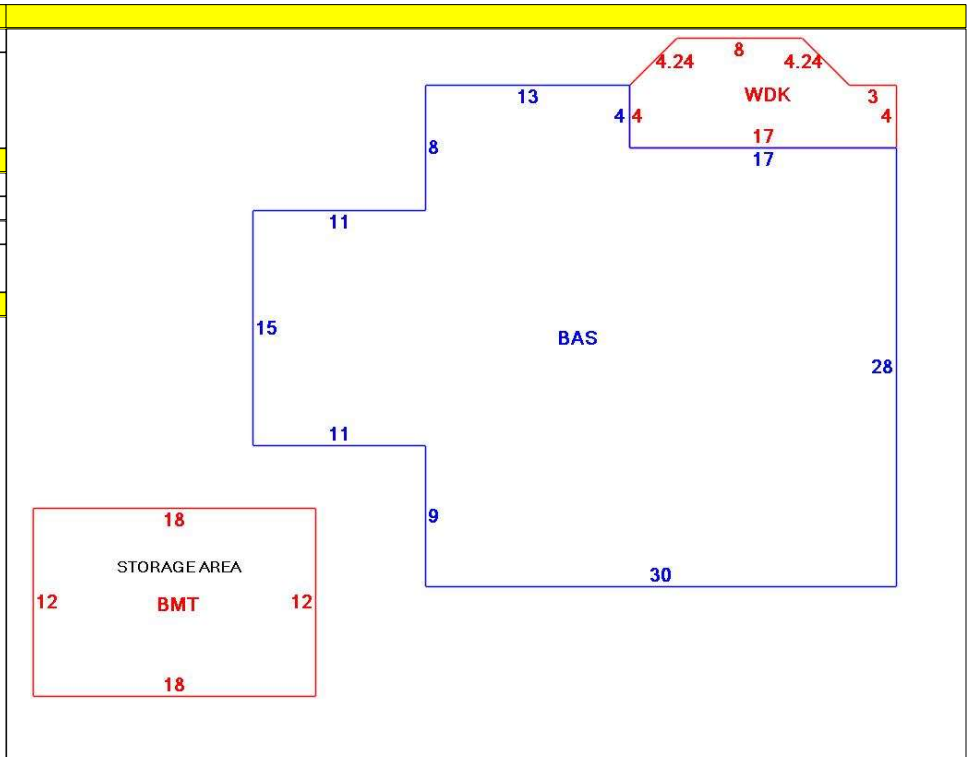

OB - OUTBUILDING & YARD ITEMS(L) / XF - BUILDING EXTRA FEATURES(B)										
Code	Description	L/B	Units	Unit Price	Yr Blt	Cond. Cd	% Gd	Grade	Grade Adj.	Appr. Value
BMT	Basement-Unfi	B	216	26.01	2005		87		0.00	8,700
WDC	Wood Deck w/	L	101	18.00	2018		98		0.00	3,100

BUILDING SUB-AREA SUMMARY SECTION						
Code	Description	Living Area	Floor Area	Eff Area	Unit Cost	Undeprec Value
BAS	First Floor	1,057	1,057	1,057	289.35	305,841
BMT	Basement Area	0	216	0	0.00	0
WDC	Wood Deck	0	101	0	0.00	0
Ttl Gross Liv / Lease Area		1,057	1,374	1,057		305,841

