

CURRENT OWNER		TOPO	UTILITIES	STRT / ROAD	LOCATION	CURRENT ASSESSMENT						801 FY2025 BARNSTABLE, MA  <b>VISION</b>								
KRUGER, ELIZABETH TR EMKCC TRUST 720 PITCHER'S WAY UNIT 50 BLDG F  HYANNIS MA 02601						Description	Code	Assessed	Assessed											
						4 Hyannis CU	RESIDNTL	1020	278,300	278,300										
		SUPPLEMENTAL DATA																		
		Alt Prcl ID	Split Zonin	BID Parcel	ResExpt Q	#DL 1	UNIT 50	#DL 2	BLDG F	GIS ID	F_981842_2703782	Plan Ref.	447/55,59	Land Ct#	#SR	Life Estate	PP STATU	Assoc Pid#		
						Total		278,300	278,300											
RECORD OF OWNERSHIP		BK-VOL/PAGE	SALE DATE	Q/U	V/I	SALE PRICE	VC	PREVIOUS ASSESSMENTS (HISTORY)												
KRUGER, ELIZABETH TR		36343	248	05-02-2024	U	I	1	1F	Year	Code	Assessed	Year	Code	Assessed V	Year	Code	Assessed			
GREENE, ELIZABETH F		15533	0051	08-29-2002	Q	I	146,000	00	2025	1020	278,300	2024	1020	239,600	2023	1020	228,600			
STEPHENS, LINDA M		13918	0080	06-08-2001	U	I	120,000	1K												
LIVING INDEPENDENTLY FOREVER INC		10836	0154	07-03-1997	U	I	56,000	1B												
BRUEN, ANN L		6501	0052	10-27-1988	U	I	0	1B												
						Total		278,300	Total	239,600	Total	228,600								
EXEMPTIONS			OTHER ASSESSMENTS					This signature acknowledges a visit by a Data Collector or Assessor												
Year	Code	Description	Amount	Code	Description	Number	Amount	Comm Int												
		Total	0.00																	
ASSESSING NEIGHBORHOOD						APPRAISED VALUE SUMMARY														
Nbhd	Nbhd Name	B	Tracing	Batch																
0001				HYAN																
NOTES												Appraised Bldg. Value (Card)		268,600						
												Appraised Xf (B) Value (Bldg)		6,600						
												Appraised Ob (B) Value (Bldg)		3,100						
												Appraised Land Value (Bldg)		0						
												Special Land Value		0						
												Total Appraised Parcel Value		278,300						
												Valuation Method		C						
												Total Appraised Parcel Value		278,300						
BUILDING PERMIT RECORD												VISIT / CHANGE HISTORY								
Permit Id	Issue Date	Type	Description	Amount	Insp Date	% Comp	Date Comp	Comments	Date	Id	Type	Is	Cd	Purpost/Result						
									04-23-2020	WD			FR	Field Review						
									12-11-2018	SR	02		03	Cycl Insp Comp						
									02-03-2016	AL	22		22	Change of Address						
									09-16-2013	TP	03		16	In Office Review						
LAND LINE VALUATION SECTION																				
B	Use Code	Description	Zone	Dist	Land Type	Land Units	Unit Price	Size Adj	Site Index	Cond.	Nbhd.	Nbhd. Adj	Notes	Location Adjustmen	Adj Unit P	Land Value				
1	102U	Condominium M	RB	4	Hyannis	0 SF	0.00	1.00000	5	1.00	0001	1.000		0.0000	0	0				
Total Card Land Units						0 SF	Parcel Total Land Area						0.00	Total Land Value			0			

CONSTRUCTION DETAIL			CONSTRUCTION DETAIL (CONTINUED)		
Element	Cd	Description	Element	Cd	Description
Style	55	Condominium			
Model	05	Res Condo			
Grade	C	Average			
Stories	1	1 Story			
Occupancy	0				
Interior Wall 1	05	Drywall			
Interior Wall 2					
Interior Floor 1	14	Carpet			
Interior Floor 2					
Heat Fuel	04	Electric			
Heat Type	07	Elec Baseboard			
AC Type	01	None			
Bedrooms	02	2 Bedrooms			
Full Baths	1	1 Full			
Half Baths	0				
Extra Fixtures					
Total Rooms	4	4 Rooms			
Bath Style					
Kitchen Style					
Master Deed L	1025	1 Full-0 Half			
Bath Split	10	Mixed			
Foundation	08				
AC Type Alt					
Sewer Occupan					
<b>CONDO DATA</b>					
Parcel Id	104288	C 0760	Owne	1.5	
	SEA MEADOW VIL	B 1	S 1		
Adjust Type	Code	Description	Factor%		
Condo Flr	1FE	FIRST FL END	100		
Condo Unit	MKT0	MKT0	100		
<b>COST / MARKET VALUATION</b>					
Building Value New		308,721			
Year Built		1988			
Effective Year Built		2007			
Depreciation Code		A			
Remodel Rating					
Year Remodeled		13			
Depreciation %		0			
Functional Obsol		0			
External Obsol		0			
Trend Factor		1			
Condition					
Condition %		87			
Percent Good		268,600			
Cns Sect Rcnld					
Dep % Ovr					
Dep Ovr Comment					
Misc Imp Ovr					
Misc Imp Ovr Comment					
Cost to Cure Ovr					
Cost to Cure Ovr Comment					

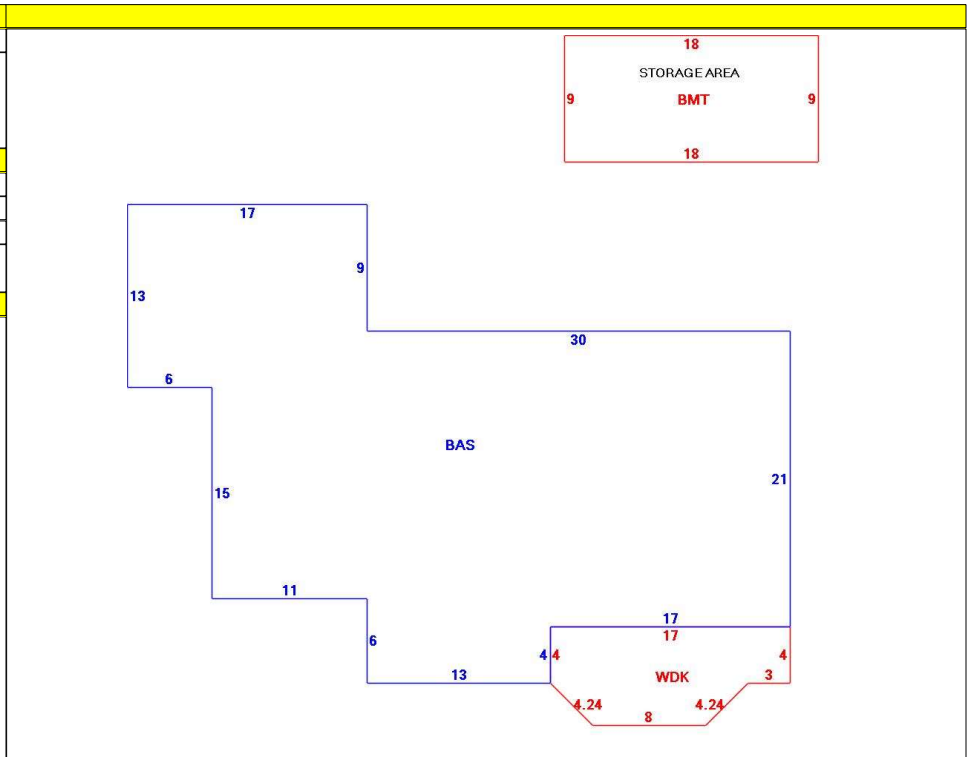

OB - OUTBUILDING & YARD ITEMS(L) / XF - BUILDING EXTRA FEATURES(B)										
Code	Description	L/B	Units	Unit Price	Yr Blt	Cond. Cd	% Gd	Grade	Grade Adj.	Appr. Value
BMT	Basement-Unfi	B	162	26.01	2005		87		0.00	6,600
WDC	Wood Deck w/	L	101	18.00	2018		98		0.00	3,100

BUILDING SUB-AREA SUMMARY SECTION						
Code	Description	Living Area	Floor Area	Eff Area	Unit Cost	Undeprec Value
BAS	First Floor	1,068	1,068	1,068	289.07	308,721
BMT	Basement Area	0	162	0	0.00	0
WDC	Wood Deck	0	101	0	0.00	0
Ttl Gross Liv / Lease Area		1,068	1,331	1,068		308,721

