

CONSTRUCTION DETAIL			CONSTRUCTION DETAIL (CONTINUED)		
Element	Cd	Description	Element	Cd	Description
Style	01	Ranch			
Model	01	Residential			
Grade:	C	Average			
Stories	1	1 Story			
Exterior Wall 1	25	Vinyl Siding			
Exterior Wall 2					
RooF Structure	03	Gable/Hip			
RooF Cover	03	Asph/F Gls/Cmp			
Interior Wall 1	05	Drywall			
Interior Wall 2					
Interior Floor 1	14	Carpet			
Interior Floor 2	12	Hardwood			
Heat Fuel	03	Gas			
Heat Type	05	Hot Water			
AC Type	03	Central			
Bedrooms	04	4 Bedrooms			
Full Baths	2				
Half Baths	1				
Extra Fixtures					
Total Rooms	7	7 Rooms			
Bath Style					
Kitchen Style					
Occupancy					
Sewer Occupan					
Accessory Apt	Y	Apt here			
Foundation Alt	01	Poured Conc.			
Rms Prts					
Bath Split	21	2 Full-1 Half			
			CONDO DATA		
			Parcel Id	C	Owne 0.0
				B	S
			Adjust Type	Code	Description
			Condo Flr		Factor%
			Condo Unit		
			COST / MARKET VALUATION		
			Building Value New		458,217
			Year Built		1978
			Effective Year Built		2004
			Depreciation Code		G
			Remodel Rating		
			Year Remodeled		
			Depreciation %		16
			Functional Obsol		0
			External Obsol		0
			Trend Factor		1
			Condition		
			Condition %		
			Percent Good		84
			RCNLD		384,900
			Dep % Ovr		
			Dep Ovr Comment		
			Misc Imp Ovr		
			Misc Imp Ovr Comment		
			Cost to Cure Ovr		
			Cost to Cure Ovr Comment		

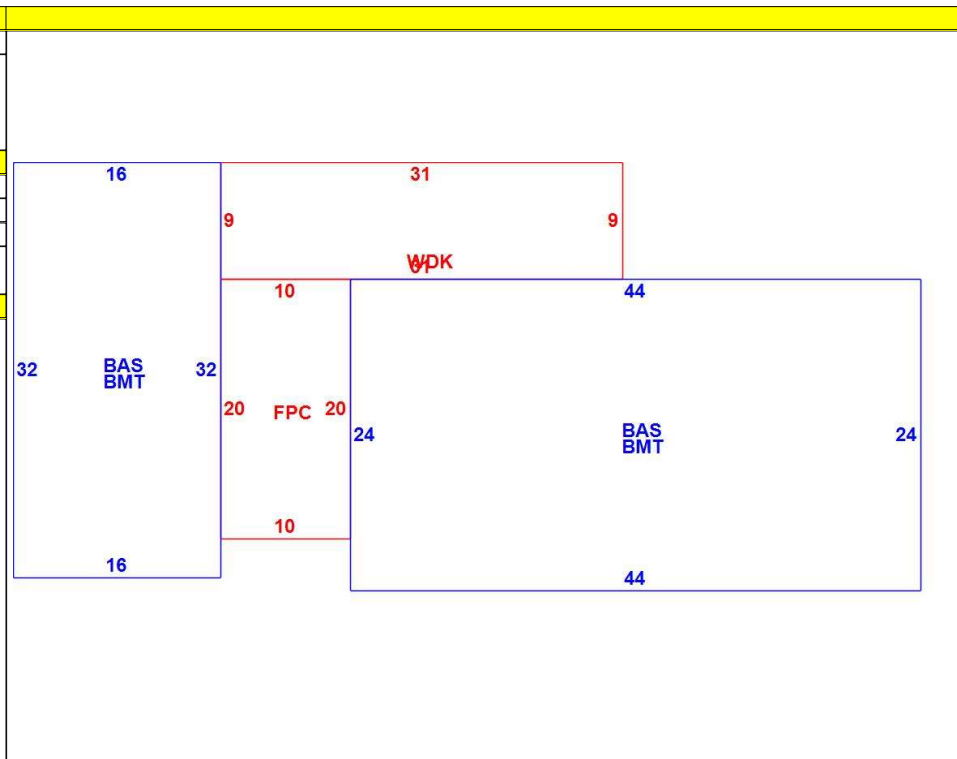

OB - OUTBUILDING & YARD ITEMS(L) / XF - BUILDING EXTRA FEATURES(B)										
Code	Description	L/B	Units	Unit Price	Yr Blt	Cond. Cd	% Gd	Grade	Grade Adj.	Appr. Value
FPL1	Fireplace 1 sto	B	1	5000.00	2002		84		0.00	4,200
BFA	Bsmt Fin-Avg	B	240	17.36	2002		84		0.00	3,500
WDC	Wood Deck w/	L	279	18.00	2023		98		0.00	5,100
FOPC	Open Prch-roo	B	200	55.00	2002		84		0.00	6,600
BMT	Basement-Unfi	B	1,568	26.01	2002		84		0.00	30,700
SHD2	Shed w/Elec	L	80	26.00	2017		96		0.00	2,000
SOL1	Solar PV Pane	B	19	860.00			0		0.00	0
SOL1	Solar PV Pane	B	13	860.00	2023		0		0.00	0
SHD2	Shed w/Elec	L	200	26.00	2023		98		0.00	5,100

BUILDING SUB-AREA SUMMARY SECTION						
Code	Description	Living Area	Floor Area	Eff Area	Unit Cost	Undeprec Value
BAS	First Floor	1,568	1,568	1,568	292.23	458,217
BMT	Basement Area	0	1,568	0	0.00	0
FPC	Open Porch Conc. Floor	0	200	0	0.00	0
WDK	Wood Deck	0	279	0	0.00	0
Ttl Gross Liv / Lease Area		1,568	3,615	1,568		458,217

