

CURRENT OWNER		TOPO	UTILITIES	STRT / ROAD	LOCATION	CURRENT ASSESSMENT				
WATSON, PAUL S & JEAN M TRS						Description	Code	Assessed	Assessed	801 FY2025 BARNSTABLE, MA
WATSON REV TR					4	RESIDENTL	1010	442,100	442,100	
143 CENTERBOARD LANE		SUPPLEMENTAL DATA				RES LAND	1010	142,000	142,000	VISION
HYANNIS MA 02601		Alt Prcl ID		Plan Ref. 425/31						
		Split Zonin		Land Ct#						
		BID Parcel		#SR						
		ResExpt Q		Life Estate						
		#DL 1 LOT 24		PP STATU						
		#DL 2		Assoc Pid#						
		GIS ID F_980597_2707405				Total 584,100 584,100				

RECORD OF OWNERSHIP		BK-VOL/PAGE	SALE DATE	Q/U	V/I	SALE PRIC	VC	PREVIOUS ASSESSMENTS (HISTORY)								
WATSON, PAUL S & JEAN M TRS		34610 136	10-28-2021	U	I	1	1F	Year	Code	Assessed	Year	Code	Assessed			
WATSON, PAUL S & JEAN M		28388 0111	09-17-2014	U	I	304,000	1	2025	1010	442,100	2024	1010	432,800			
WALKER, DORIS P TR		20476 0042	11-16-2005	U	I	100	1A		1010	142,000	2023	1010	372,800			
WALKER, DORIS P		10294 0192	07-15-1996	U	I	1	A									
WALKER, DORIS P		10105 0178	03-15-1996	U	I	145,000	P									
Total								584,100		Total		574,800		Total		501,900

EXEMPTIONS			OTHER ASSESSMENTS					
Year	Code	Description	Amount	Code	Description	Number	Amount	Comm Int
								This signature acknowledges a visit by a Data Collector or Assessor
Total			0.00					

ASSESSING NEIGHBORHOOD			
Nbhd	Nbhd Name	B	Tracing
0107			Batch HYAN

NOTES			

BUILDING PERMIT RECORD									VISIT / CHANGE HISTORY					
Permit Id	Issue Date	Type	Description	Amount	Insp Date	% Comp	Date Comp	Comments	Date	Id	Type	Is	Cd	Purpost/Result
BLDR-21-14	11-08-2021	839	Solar Panel-Re	5,501	01-28-2022	100	06-30-2022	Install of roof mounted PV sola	08-17-2022	CK	03		16	In Office Review
EXPR-21-9	06-21-2021	835	Sid/Wind/Roof/	4,228	06-30-2021	100	06-30-2021	REMOVE AND REPLACE 6 D	12-06-2021	BM	22		22	Change of Address
17-2427	08-21-2017	822	Insulation	3,391	06-30-2018	100	06-30-2018	Air sealing & weatherization	04-28-2020	WD			FR	Field Review
201503493	06-15-2015	AD	Addition	24,000	09-04-2015	100	06-30-2016	REQUEST TO BUILD A THRE	02-22-2016	SR	01		02	Bldg Permit Completed
201406847	10-08-2014	NR	New Roof	12,500	06-30-2015	100	06-30-2015	RE-ROOFING (STRIPPING O	08-05-1997	LK	01		00	Meas/Listed-Interior Acces
11727	11-01-1995	DW	Dwelling	60,000	08-05-1997	100	01-01-1997	HY 1 STOR						

LAND LINE VALUATION SECTION																
B	Use Code	Description	Zone	LA	Land Units	Unit Price	Size Adj	AC Disc	Site Index	Cond.	Nbhd.	Nbhd. Adj	Notes	Location Adjustmen	Adj Unit P	Land Value
1	1010	Single Fam M-0	RC-	4	0.190 AC	176,344.00	4.23746	1.0000	5	1.00	0105	1.000		1.0000	747,257.7	142,000
Total Card Land Units					0.19	AC	Parcel Total Land Area					0.19	Total Land Value			142,000

CONSTRUCTION DETAIL			CONSTRUCTION DETAIL (CONTINUED)		
Element	Cd	Description	Element	Cd	Description
Style	01	Ranch			
Model	01	Residential			
Grade:	C+	Average Plus			
Stories	1	1 Story			
Exterior Wall 1	11	Clapboard			
Exterior Wall 2	14	Wood Shingle			
RooF Structure	03	Gable/Hip			
RooF Cover	03	Asph/F Gls/Cmp			
Interior Wall 1	03	Plastered			
Interior Wall 2					
Interior Floor 1	12	Hardwood			
Interior Floor 2	14	Carpet			
Heat Fuel	03	Gas			
Heat Type	04	Hot Air			
AC Type	03	Central			
Bedrooms	03	3 Bedrooms			
Full Baths	2				
Half Baths	0				
Extra Fixtures					
Total Rooms	6	6 Rooms			
Bath Style					
Kitchen Style					
Occupancy					
Sewer Occupan					
Accessory Apt					
Foundation Alt	01	Poured Conc.			
Rms Prts					
Bath Split	20	2 Full-0 Half			
			CONDO DATA		
			Parcel Id		C
			Owne 0.0		
			Adjust Type	Code	Description
			Condo Flr		
			Condo Unit		
			COST / MARKET VALUATION		
			Building Value New 439,702		
			Year Built 1996		
			Effective Year Built 2008		
			Depreciation Code A		
			Remodel Rating		
			Year Remodeled		
			Depreciation % 12		
			Functional Obsol 0		
			External Obsol 0		
			Trend Factor 1		
			Condition		
			Condition %		
			Percent Good 88		
			RCNLD 386,900		
			Dep % Ovr		
			Dep Ovr Comment		
			Misc Imp Ovr		
			Misc Imp Ovr Comment		
			Cost to Cure Ovr		
			Cost to Cure Ovr Comment		

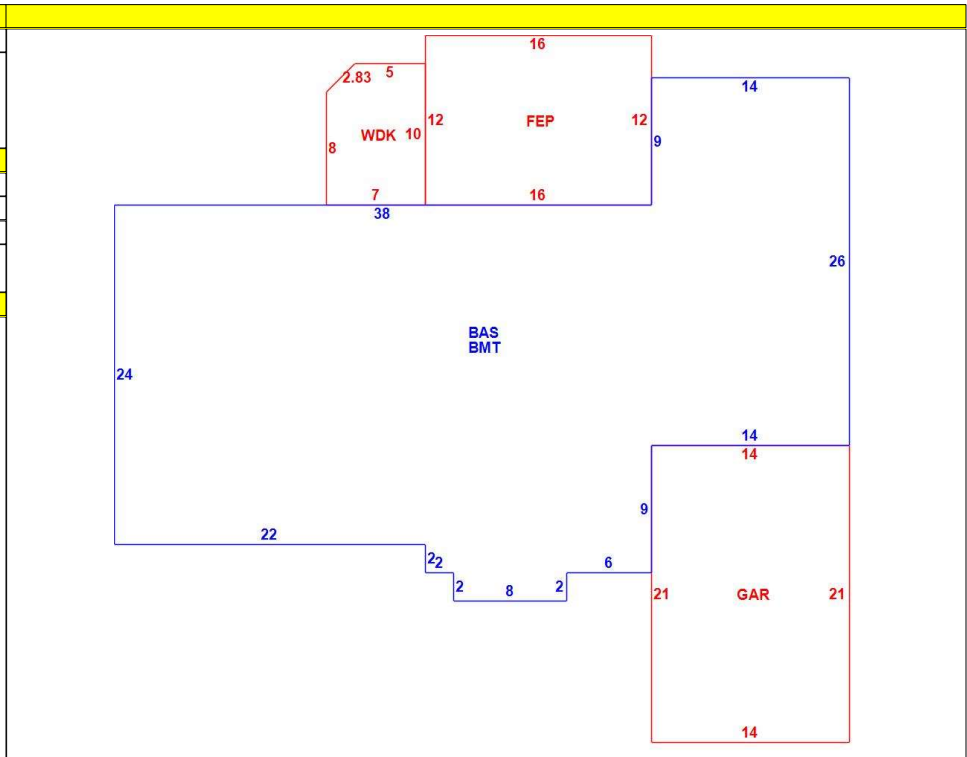

OB - OUTBUILDING & YARD ITEMS(L) / XF - BUILDING EXTRA FEATURES(B)										
Code	Description	L/B	Units	Unit Price	Yr Blt	Cond. Cd	% Gd	Grade	Grade Adj.	Appr. Value
WDC	Wood Decking	L	68	20.00	2003		68		0.00	2,200
GAR	Attached Gara	B	294	40.00	2006		88		0.00	11,600
BMT	Basement-Unfi	B	1,324	26.01	2006		88		0.00	28,400
FEP	Enclosed porc	B	192	70.00	2006		88		0.00	10,800
FPLG	Gas Fireplace-	B	1	2500.00	2006		88		0.00	2,200
SOL1	Solar PV Pane	B	12	860.00	2006		0		0.00	0

BUILDING SUB-AREA SUMMARY SECTION						
Code	Description	Living Area	Floor Area	Eff Area	Unit Cost	Undeprec Value
BAS	First Floor	1,324	1,324	1,324	332.10	439,702
BMT	Basement Area	0	1,324	0	0.00	0
FEP	Enclosed Porch	0	192	0	0.00	0
GAR	Attached Garage	0	294	0	0.00	0
WDC	Wood Deck	0	68	0	0.00	0
Ttl Gross Liv / Lease Area		1,324	3,202	1,324		439,702

