

CONSTRUCTION DETAIL			CONSTRUCTION DETAIL (CONTINUED)		
Element	Cd	Description	Element	Cd	Description
Style	01	Ranch			
Model	01	Residential			
Grade:	C+	Average Plus			
Stories	1	1 Story			
Exterior Wall 1	11	Clapboard			
Exterior Wall 2	14	Wood Shingle			
RooF Structure	03	Gable/Hip			
RooF Cover	03	Asph/F Gls/Cmp			
Interior Wall 1	03	Plastered			
Interior Wall 2					
Interior Floor 1	12	Hardwood			
Interior Floor 2	14	Carpet			
Heat Fuel	03	Gas			
Heat Type	04	Hot Air			
AC Type	03	Central			
Bedrooms	03	3 Bedrooms			
Full Baths	2				
Half Baths	0				
Extra Fixtures					
Total Rooms	7	7 Rooms			
Bath Style	02	Average			
Kitchen Style	02	Modernized			
Occupancy					
Sewer Occupan					
Accessory Apt					
Foundation Alt	01	Poured Conc.			
Rms Prts					
Bath Split	20	2 Full-0 Half			
CONDO DATA					
Parcel Id		C	Owne	0.0	
Adjust Type	Code	Description	Factor%		
Condo Flr					
Condo Unit					
COST / MARKET VALUATION					
Building Value New		509,729			
Year Built		1997			
Effective Year Built		2008			
Depreciation Code		A			
Remodel Rating					
Year Remodeled					
Depreciation %		12			
Functional Obsol		0			
External Obsol		0			
Trend Factor		1			
Condition					
Condition %					
Percent Good		88			
RCNLD		448,600			
Dep % Ovr					
Dep Ovr Comment					
Misc Imp Ovr					
Misc Imp Ovr Comment					
Cost to Cure Ovr					
Cost to Cure Ovr Comment					

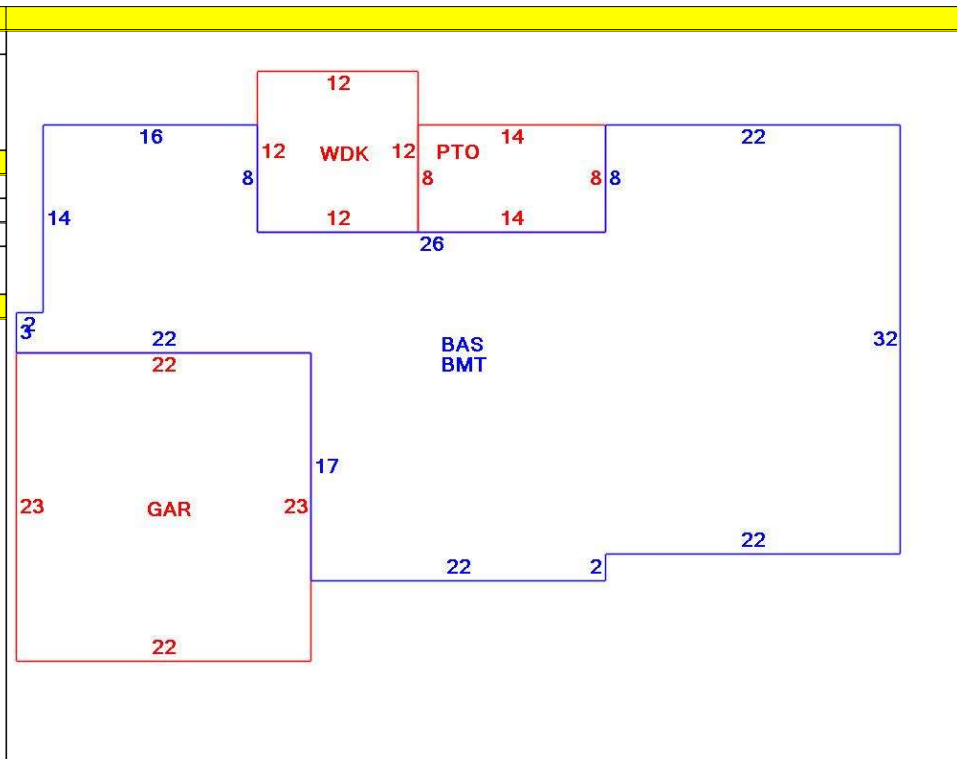

OB - OUTBUILDING & YARD ITEMS(L) / XF - BUILDING EXTRA FEATURES(B)										
Code	Description	L/B	Units	Unit Price	Yr Blt	Cond. Cd	% Gd	Grade	Grade Adj.	Appr. Value
FPLG	Gas Fireplace-	B	1	2500.00	2006		88		0.00	2,200
WDC	Wood Deck w/	L	144	18.00	2004		70		0.00	2,500
GAR	Attached Gara	B	506	40.00	2006		88		0.00	16,400
BMT	Basement-Unfi	B	1,590	26.01	2006		88		0.00	32,500
PAT2	Patio-Good	L	112	9.94	2017		98		0.00	1,300

BUILDING SUB-AREA SUMMARY SECTION						
Code	Description	Living Area	Floor Area	Eff Area	Unit Cost	Undeprec Value
BAS	First Floor	1,590	1,590	1,590	320.58	509,729
BMT	Basement Area	0	1,590	0	0.00	0
GAR	Attached Garage	0	506	0	0.00	0
PTO	Patio	0	112	0	0.00	0
WDK	Wood Deck	0	144	0	0.00	0
Ttl Gross Liv / Lease Area		1,590	3,942	1,590		509,729

