

CURRENT OWNER		TOPO	UTILITIES	STRT / ROAD	LOCATION	CURRENT ASSESSMENT						801 FY2025 BARNSTABLE, MA VISION						
LEROY, SARA A 1431 IYANNOUGH RD - UNIT A-2 CENTERVILLE MA 02632						Description	Code	Assessed	Assessed									
						4 Hyannis CU	RESIDNTL	1020	290,700	290,700								
		SUPPLEMENTAL DATA																
		Alt Prcl ID	Split Zonin B;RC-1		Plan Ref. 315/66, 319/20, 3													
		BID Parcel			Land Ct#													
		ResExpt Q			#SR													
		#DL 1	UNIT 2U		Life Estate													
		#DL 2	BLDG A		PP STATU													
		GIS ID	F_979524_2709499		Assoc Pid#													
						Total		290,700	290,700									
RECORD OF OWNERSHIP		BK-VOL/PAGE	SALE DATE	Q/U	V/I	SALE PRICE	VC	PREVIOUS ASSESSMENTS (HISTORY)										
LEROY, SARA A		19236 0105	11-12-2004	Q	I	205,000	00	Year	Code	Assessed	Year	Code	Assessed					
VARGAS, JOSEPH &		18331 0133	03-18-2004	U	I	115,100	1F	2025	1020	290,700	2024	1020	249,700					
VARGAS, JOSEPH &		17658 0217	09-17-2003	Q	I	155,100	00				2023	1020	208,800					
CAVILL, RICHARD J JR & MARISTELA M		17187 0082	07-01-2003	U	I	100	1A											
CAVILL, RICHARD J JR		12170 0332	04-01-1999	Q	I	70,000	00	Total		290,700	Total		249,700					
								Total		290,700	Total		249,700					
								Total		290,700	Total		208,800					
EXEMPTIONS			OTHER ASSESSMENTS				This signature acknowledges a visit by a Data Collector or Assessor											
Year	Code	Description	Amount	Code	Description	Number	Amount	Comm Int										
Total			0.00															
ASSESSING NEIGHBORHOOD																		
Nbhd	Nbhd Name		B	Tracing		Batch												
0001						HYAN												
NOTES																		
BUILDING PERMIT RECORD								VISIT / CHANGE HISTORY										
Permit Id	Issue Date	Type	Description	Amount	Insp Date	% Comp	Date Comp	Comments	Date	Id	Type	Is	Cd	Purpost/Result				
									04-28-2020	WD			FR	Field Review				
									12-14-2018	SR	02		03	Cycl Insp Comp				
									02-24-2016	TR	03		16	In Office Review				
									08-28-2014	TP	03		16	In Office Review				
LAND LINE VALUATION SECTION																		
B	Use Code	Description	Zone	Dist	Land Type	Land Units	Unit Price	Size Adj	Site Index	Cond.	Nbhd.	Nbhd. Adj	Notes	Location Adjustmen	Adj Unit P	Land Value		
1	102U	Condominium M	SPLI	4	Hyannis	0 SF	0.00	1.00000	5	1.00	0001	1.000		0.0000	0	0		
Total Card Land Units						0 SF	Parcel Total Land Area						0.00	Total Land Value				0

CONSTRUCTION DETAIL			CONSTRUCTION DETAIL (CONTINUED)		
Element	Cd	Description	Element	Cd	Description
Style	55	Condominium			
Model	05	Res Condo			
Grade	C	Average			
Stories	1	1 Story			
Occupancy	0				
Interior Wall 1	03	Plastered			
Interior Wall 2					
Interior Floor 1	14	Carpet			
Interior Floor 2	09	Pine/Soft Wood			
Heat Fuel	04	Electric			
Heat Type	07	Elec Baseboard			
AC Type	01	None			
Bedrooms	02	2 Bedrooms			
Full Baths	1	1 Full			
Half Baths	0				
Extra Fixtures					
Total Rooms	5	5 Rooms			
Bath Style					
Kitchen Style					
Master Deed L	1155				
Bath Split	10	1 Full-0 Half			
Foundation	01	Poured Conc.			
AC Type Alt					
Sewer Occupan					

CONDO DATA			
Parcel Id	104261	C 0450	Ownr 3.3
	STRAWBERRY HIL	B 1	S 1
Adjust Type	Code	Description	Factor%
Condo Flr			100
Condo Unit	MKT0	MKT0	100

COST / MARKET VALUATION	
Building Value New	326,858
Year Built	1976
Effective Year Built	2002
Depreciation Code	A
Remodel Rating	
Year Remodeled	
Depreciation %	17
Functional Obsol	0
External Obsol	0
Trend Factor	1
Condition	
Condition %	
Percent Good	83
Cns Sect Rcnd	271,300
Dep % Ovr	
Dep Ovr Comment	
Misc Imp Ovr	
Misc Imp Ovr Comment	
Cost to Cure Ovr	
Cost to Cure Ovr Comment	

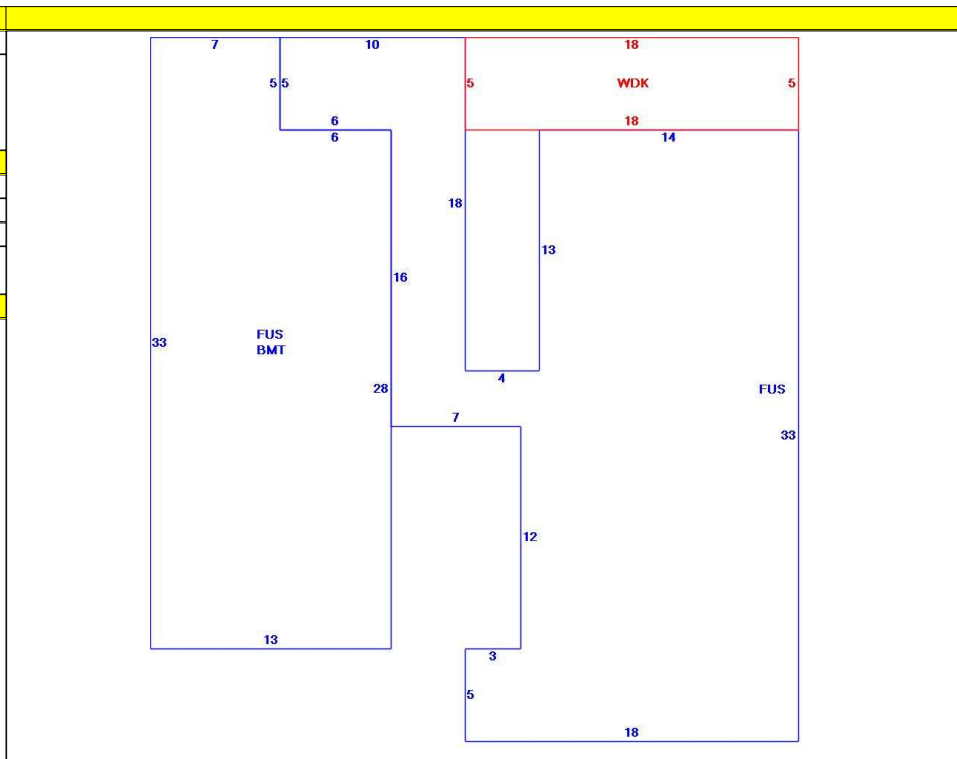

OB - OUTBUILDING & YARD ITEMS(L) / XF - BUILDING EXTRA FEATURES(B)										
Code	Description	L/B	Units	Unit Price	Yr Blt	Cond. Cd	% Gd	Grade	Grade Adj.	Appr. Value
FPL1	Fireplace 1 sto	B	1	5000.00	1999		83		0.00	4,200
BMT	Basement-Unfi	B	399	26.01	1999		83		0.00	11,800
WDC	Wood Decking	L	90	20.00	2018		98		0.00	3,400

BUILDING SUB-AREA SUMMARY SECTION						
Code	Description	Living Area	Floor Area	Eff Area	Unit Cost	Undeprec Value
BMT	Basement Area	0	399	0	0.00	0
FUS	Upper Story	1,019	1,019	1,019	320.76	326,858
WDC	Wood Deck	0	90	0	0.00	0
Ttl Gross Liv / Lease Area		1,019	1,508	1,019		326,858

