

CURRENT OWNER		TOPO	UTILITIES	STRT / ROAD	LOCATION	CURRENT ASSESSMENT						801 FY2025 BARNSTABLE, MA VISION					
HAYES, JEFFREY A 1674 MULBERRY LANE SAN JOSE CA 95125						Description	Code	Assessed	Assessed								
						RESIDNTL	1010	259,800	259,800								
					4	RES LAND	1010	171,300	171,300								
SUPPLEMENTAL DATA						Total						431,100	431,100				
Alt Prcl ID		Split Zonin		Plan Ref. 96/137													
SAN JOSE CA 95125		BID Parcel		Land Ct#													
#DL 1 LOT 36		ResExpt Q		#SR													
#DL 2		Life Estate		PP STATU													
GIS ID F_984608_2696336		Assoc Pid#															
RECORD OF OWNERSHIP		BK-VOL/PAGE	SALE DATE	Q/U	V/I	SALE PRIC	VC	PREVIOUS ASSESSMENTS (HISTORY)									
HAYES, JEFFREY A		11821 0139	11-06-1998	U	I	1	1A	Year	Code	Assessed	Year	Code	Assessed	Year	Code	Assessed	
CONLEY, CATHERINE		7518 0116	05-02-1991	U	I	1	A	2025	1010	259,800	2024	1010	243,600	2023	1010	220,200	
CONLEY, ARTHUR & CATHERINE		1380 0686	10-11-1967	U		0			1010	171,300		1010	171,300		1010	169,300	
								Total		431,100	Total		414,900	Total		389,500	
EXEMPTIONS			OTHER ASSESSMENTS				This signature acknowledges a visit by a Data Collector or Assessor										
Year	Code	Description	Amount	Code	Description	Number	Amount	Comm Int									
Total			0.00														
ASSESSING NEIGHBORHOOD						APPRAISED VALUE SUMMARY											
Nbhd	Nbhd Name		B	Tracing		Batch											
0106						HYAN											
NOTES																	
BUILDING PERMIT RECORD								VISIT / CHANGE HISTORY									
Permit Id	Issue Date	Type	Description	Amount	Insp Date	% Comp	Date Comp	Comments	Date	Id	Type	Is	Cd	Purpost/Result			
									05-26-2020	WD			FR	Field Review			
									10-06-2017	SR	02		03	Cycl Insp Comp			
									02-11-2014	TR	22		22	Change of Address			
									02-03-2014	DR	03		16	In Office Review			
									01-23-2014	JR	03		16	In Office Review			
									11-15-1988	ML	01		00	Meas/Listed-Interior Acces			
LAND LINE VALUATION SECTION																	
B	Use Code	Description	Zone	LA	Land Units	Unit Price	Size Adj	AC Disc	Site Index	Cond.	Nbhd.	Nbhd. Adj	Notes	Location Adjustmen	Adj Unit P	Land Value	
1	1010	Single Fam M-0	RB	4	0.250 AC	176,344.00	3.37919	1.0000	5	1.00	0106	1.150		1.0000	685,290.4	171,300	
Total Card Land Units					0.25	AC	Parcel Total Land Area					0.25	Total Land Value			171,300	

CONSTRUCTION DETAIL			CONSTRUCTION DETAIL (CONTINUED)		
Element	Cd	Description	Element	Cd	Description
Style	04	Cape Cod			
Model	01	Residential			
Grade:	C	Average			
Stories	1.15	1 Story w/FAT			
Exterior Wall 1	14	Wood Shingle			
Exterior Wall 2					
RooF Structure	03	Gable/Hip			
RooF Cover	03	Asph/F Gls/Cmp			
Interior Wall 1	05	Drywall			
Interior Wall 2					
Interior Floor 1	14	Carpet			
Interior Floor 2					
Heat Fuel	02	Oil			
Heat Type	05	Hot Water			
AC Type	01	None			
Bedrooms	02	2 Bedrooms			
Full Baths	1				
Half Baths	0				
Extra Fixtures					
Total Rooms	4	4 Rooms			
Bath Style					
Kitchen Style					
Occupancy					
Sewer Occupan					
Accessory Apt					
Foundation Alt	01	Poured Conc.			
Rms Prts					
Bath Split	10	1 Full-0 Half			

CONDO DATA				
Parcel Id		C		Owne 0.0
Adjust Type	Code	Description	Factor%	
Condo Flr				
Condo Unit				

COST / MARKET VALUATION	
Building Value New	304,108
Year Built	1961
Effective Year Built	1990
Depreciation Code	A
Remodel Rating	
Year Remodeled	
Depreciation %	26
Functional Obsol	0
External Obsol	0
Trend Factor	1
Condition	
Condition %	
Percent Good	74
RCNLD	225,000
Dep % Ovr	
Dep Ovr Comment	
Misc Imp Ovr	
Misc Imp Ovr Comment	
Cost to Cure Ovr	
Cost to Cure Ovr Comment	

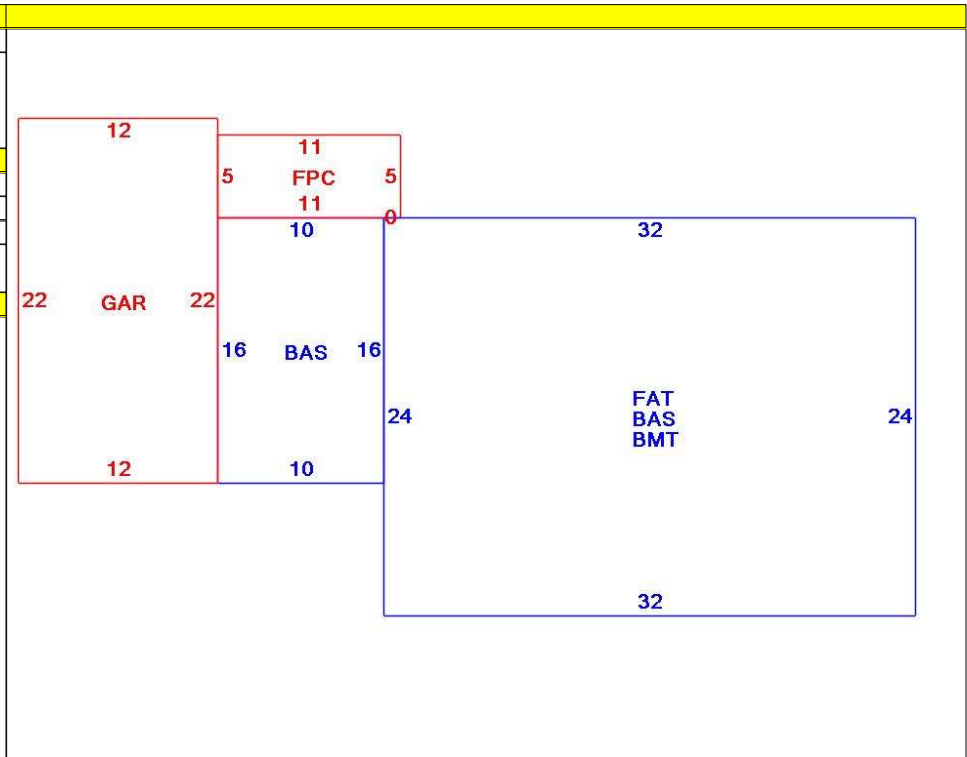

OB - OUTBUILDING & YARD ITEMS(L) / XF - BUILDING EXTRA FEATURES(B)										
Code	Description	L/B	Units	Unit Price	Yr Blt	Cond. Cd	% Gd	Grade	Grade Adj.	Appr. Value
BRR	Bsmt Rec Rm-	B	576	8.05	1988		74		0.00	3,400
FPL1	Fireplace 1 sto	B	1	5000.00	1988		74		0.00	3,700
FOPC	Open Prch-roo	B	55	55.00	1988		74		0.00	2,300
GAR	Attached Gara	B	264	40.00	1988		74		0.00	9,000
BMT	Basement-Unfi	B	768	26.01	1988		74		0.00	16,400

BUILDING SUB-AREA SUMMARY SECTION						
Code	Description	Living Area	Floor Area	Eff Area	Unit Cost	Undeprec Value
BAS	First Floor	928	928	928	291.57	270,577
BMT	Basement Area	0	768	0	0.00	0
FAT	Attic, Finished	115	768	115	43.66	33,531
FPC	Open Porch Conc. Floor	0	55	0	0.00	0
GAR	Attached Garage	0	264	0	0.00	0
Ttl Gross Liv / Lease Area		1,043	2,783	1,043		304,108

